

Modular Assembly System

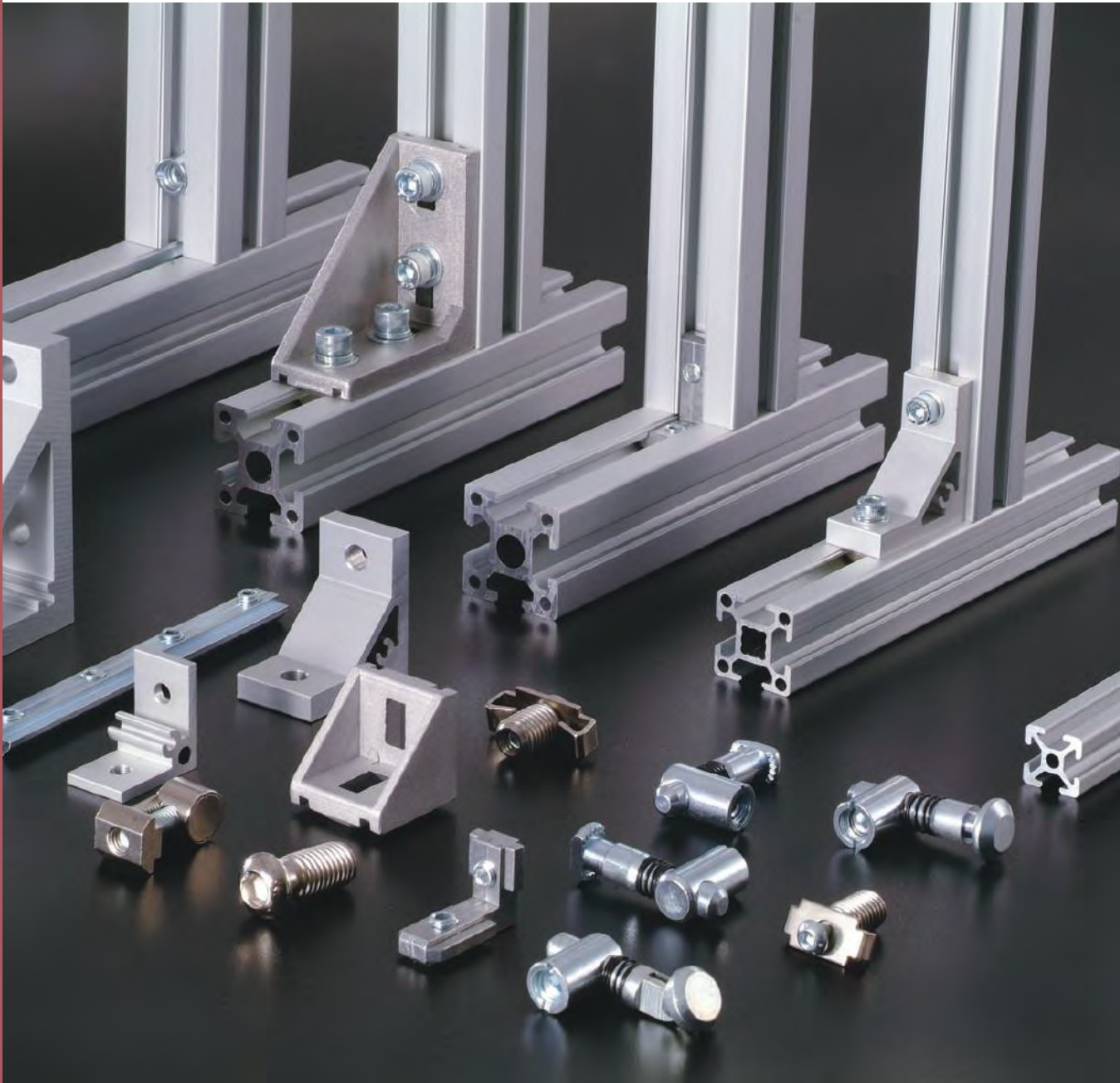





























Sistema de Ensamble Modular
Modular Assembly System





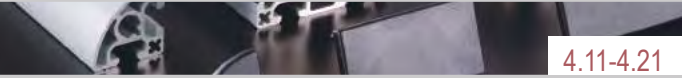























Sistema de Ensamble Modular
Modular Assembly System

Índice de Productos / Product Index

Perfiles de Aluminio Aluminum Profile 		1.11-1.41	
 Strut Profile PG15/20/30/40/45/50/60	1.11	 Clamping Profile PG30/40	1.21
 Angle Profile PG20/30/35/50/100	1.31	 Special Profile PG40	1.41
Elementos de Fijación Fastening Elements 		2.11-2.51	
 Pre-set Nut	2.11	 Square Nut	2.12
 T Nut	2.21	 Anti-torsion Subsequent Nut	2.32
 Subsequent Nut	2.31	 T Bolt	2.41
 Hole Reducer Bolt	2.51		
Elementos de Conexión Connecting Elements 		3.11-3.92	
 Anchor Connector	3.11	 Die Cast Bracket	3.21
 Angle Profile Bracket	3.31	 Inner Bracket	3.41
 Linear Bar Connector	3.51	 Butt Connector	3.61
 End Connector	3.71	 Screw Connector	3.81
 Cubic Connector	3.91	 Corner Bracket	3.92
Accesorios de Perfiles Profile Accesories 		4.11-4.21	
 End Cap	4.11	 End Cap	4.12
 T Slot Cover	4.21		

Índice de Productos / Product Index

Elementos de Apoyo <i>Floor Elements</i>			
	Base Plate	5.11	
	Mounting Plate	5.31-5.33	
	Base Angle	5.51	
		5.11-5.61	
Paneles <i>Panel Installation Elements</i>			
	T Slot Reducing Profile	6.11	
	Panel Installation Elements	6.31	
		6.11-6.31	
Puertas/Ventanas <i>Door and Window Elements</i>			
	Handle	7.11-7.13	
	Lock	7.31	
	Door Lock	7.42	
		7.11-7.51	
Accesorios Adicionales <i>Additional Accesories</i>			
	Suspended Glider	8.11	
	Joint	8.31	
	Mounting Adaptor for Roller	8.51	
		8.11-8.51	

Código de Maquinado de Perfiles / *Profile Machining Code*



Dowel bore



Inner connect bore



Screw thread bore



Cross bore



Angle cut



1.11-1.41

Perfiles de Aluminio
Strut Profile

Perfiles de Fijación
Clamping Profile

Perfiles para Cerramientos de Seguridad
Protective Grille Profile

Perfiles Ángulo
Angle Profile

Perfiles Especiales
Special Profile

1

Perfiles de Aluminio

Aluminium Profile

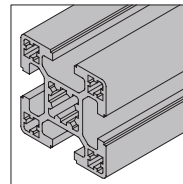

1.11

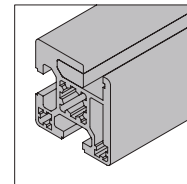

1.21

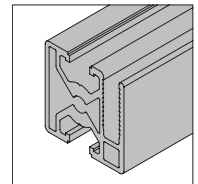

1.22

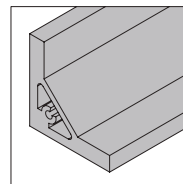

1.31

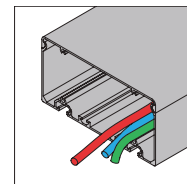

1.41

Información Técnica

Technical Data

Perfil de aluminio extruido según norma GB5237-2008, superficie anodizada, espesor de capa mínimo $\geq 11\mu$

El largo estándar de los perfiles es de 5800mm.

Extruded aluminum profile as per GB5237-2008, surface satin anodized, layer thickness min $\geq 11\mu$

Profile standard length for delivery is 5800mm.

Tensión de rotura / Tensile Strength: min.260N/mm²
 Tensión de fluencia / Yield Strength: min.240N/mm²
 Deformación / Elongation: 8%(T \leq 3.2mm) or 10%(T>3.2~25.0mm)
 Módulo de elasticidad / E-Module: approx.70,000N/mm²
 Dureza Brinell / Brinell Hardness: HB 75 2.5/187.5
 Espesor capa / Coat Thickness: $\geq 11\mu$

Resistencia a la flexión / Bending Strength

Para los cálculos de flexión, se deberán considerar las fórmulas siguientes:

For deflection calculation, please refer to the formulas below:

f (mm): Flecha / Deflection
 F (N): Tipo de carga / Type of Load
 L (mm): Largo del perfil / Profile Length
 I (cm⁴): Momento de inercia / Moment of Inertia
 E (N/mm²): Módulo de elasticidad / Modulus of Elasticity

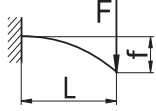
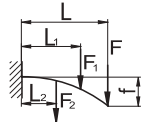
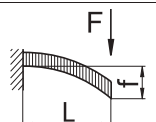
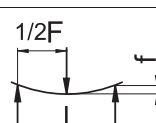
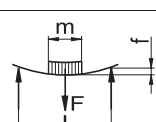
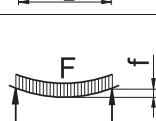
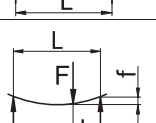
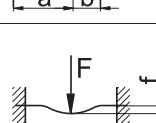
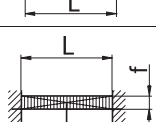
1		$f = \frac{F \cdot L^3}{3E \cdot I \cdot 10^4}$
2		$f = \frac{F \cdot L^3 + F_1 \cdot L_1^2 \cdot L + F_2 \cdot L_2^2 \cdot L}{3E \cdot I \cdot 10^4}$
3		$f = \frac{F \cdot L^3}{8E \cdot I \cdot 10^4}$
4		$f = \frac{F \cdot L^3}{48E \cdot I \cdot 10^4}$
5		$f = \frac{F \cdot L^3}{\left(48 + \frac{29m}{L}\right) \cdot E \cdot I \cdot 10^4}$
6		$f = \frac{5F \cdot L^3}{384E \cdot I \cdot 10^4}$
7		$f = \frac{F \cdot a^2 \cdot b^2}{3E \cdot I \cdot 10^4 \cdot L}$
8		$f = \frac{F \cdot L^3}{192E \cdot I \cdot 10^4}$
9		$f = \frac{F \cdot L^3}{384E \cdot I \cdot 10^4}$

Tolerancias del perfil extruido

Extruded Profile Tolerances

Tolerancia de Paralelismo

Parallelism Tolerance

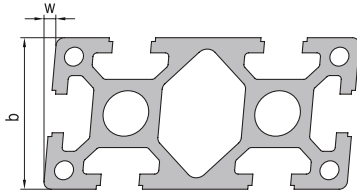

La desviación de paralelismo w se refiere a la distancia entre dos planos verticales que pasan por los vértices de una arista inclinada del perfil.

The parallelism tolerance w refers to the distance between two vertical planes passing through the vertices of an inclined face.

En función del ancho b del perfil, la tolerancia se indica en la tabla siguiente:

Based on the profile width b , the tolerance is according to the following table:

b (mm)	w (mm)
≤ 40	0.3
$>40\sim 80$	0.5
$>80\sim 180$	1.0

Tolerancia de Rectitud

Straightness Tolerance

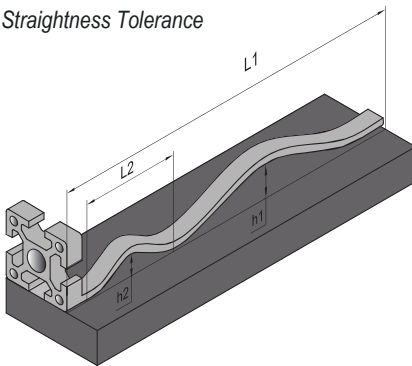

Para medir la desviación de rectitud h , el perfil se debe apoyar sobre una superficie horizontal. La tolerancia de rectitud h tiene dos condiciones:

- En cualquier posición del perfil, para una distancia $L2$ de 300mm, la altura $h2$ de desviación deberá ser menor o igual que 0,3mm.
- Para el largo total del perfil $L1$, la altura $h1$ de desviación deberá ser menor o igual que los valores indicados en la tabla siguiente:

In order to measure the height h , the profile has to be on a horizontal surface. The straightness tolerance h has two conditions:

- *For any position of the profile, for a distance $L2$ of 300mm, the height $h2$ has to be lower or equal to 0,3mm.*
- *For the total profile length $L1$, the height $h1$ has to be lower or equal to the values listed in the following table:*

$L1$ (m)	1	2	3	4	5	6
$h1$ (mm)	0.7	1.4	2.1	2.8	3.5	4.2

Tolerancia de Torsión

Twist Tolerance

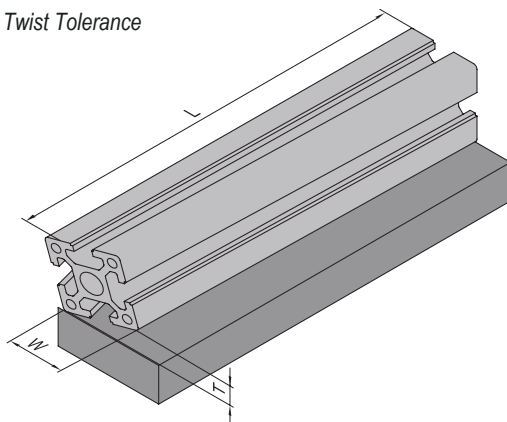

Para medir la desviación de torsión T , el perfil se debe apoyar sobre una superficie horizontal y uno de los extremos se debe fijar haciendo contacto con el plano.

La desviación de torsión T es la mayor distancia que existe desde el perfil al plano medida en el otro extremo del perfil. En función del ancho W y el largo L del perfil, la tolerancia a la torsión se puede calcular según la siguiente tabla:

In order to measure the twist height T , the profile has to be on a horizontal surface and one of its extremes has to be fixed making contact with the surface. The twist tolerance T is the largest distance between the profile edge and the surface, measured from the opposite profile end. Depending on the width W and the profile length L , the twist tolerance T can be calculated as per the following table:

W (mm)	T (mm)	
	$L\leq 1m$	$L>1m$
≤ 40	$0.052 \times W$	$0.123 \times W$
$>40\sim 80$	$0.026 \times W$	$0.087 \times W$
$80\sim 180$	$0.017 \times W$	$0.052 \times W$

Simbología de la ranura tipo T

T Slot Symbol



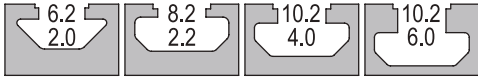

La simbología se utiliza para identificar los componentes y accesorios que son compatibles con la ranura tipo T del perfil seleccionado.
 The symbols are used to identify the components that are compatible with the T slot of the selected profile.



Compatible / Compatible

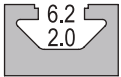
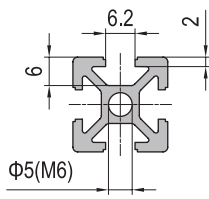

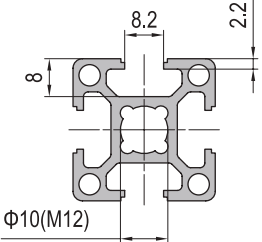
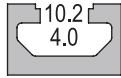
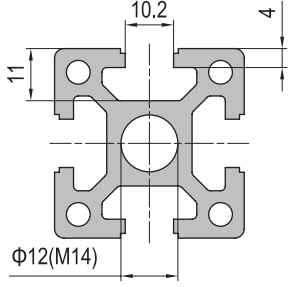
No Compatible / Not Compatible

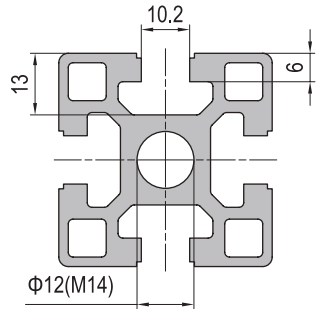
T Slot Symbol	Cross Section	Core Hole Φ	Slot Width	Slot Depth	Wall Thickness	Profile Group
		5.0	6.2	6.0	2.0	PG15 PG20
		10.0	8.2	8.0	2.2	PG30
		12.0	10.2	11.0	4.0	PG40
		12.0	10.2	13.0	6.0	PG45 PG50 PG60

Perfil de Aluminio PG15

Strut Profile PG15

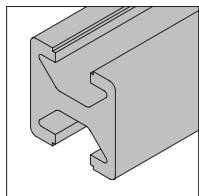

15x15 2 slots

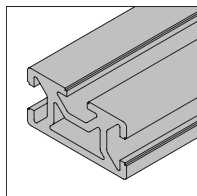

15x30 3 slots

El Perfil de Aluminio PG15 con una ranura tipo T de 6mm se utiliza para la construcción de ensamblajes modulares livianos.

Strut profile PG15 featuring 6mm T-slot is designed for constructing light weight assemblies.

15x15 2 slots

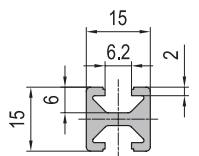

15x30 3 slots

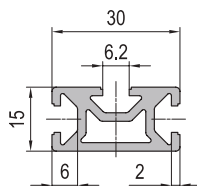

Descripción	Momento de Inercia Ix (cm ⁴)	Momento de Inercia Iy (cm ⁴)	Momento Resistente Wx (cm ³)	Momento Resistente Wy (cm ³)	Masa (kg/m)	Part No.
Strut Profile PG15 15x15 2 slots	0.2	0.4	0.3	0.5	0.4	1.11.15.015015.02
Strut Profile PG15 15x30 3 slots	0.7	1.8	0.8	1.2	0.6	1.11.15.015030.03

Selección del tipo de conector / Connector Selection



Angle Profile Bracket 3.31



Inner Bracket 3.41



linear bar connector3.51

Perfil de Aluminio PG20

Strut Profile PG20

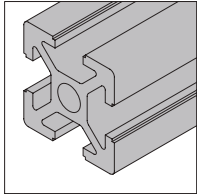

20x20 4 slots

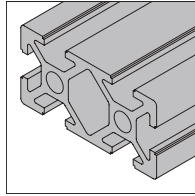

20x40 6 slots

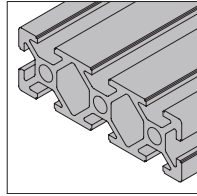

20x60 8 slots

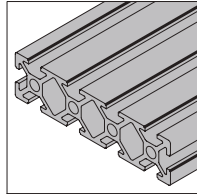

20x80 10 slots

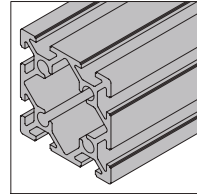

40x40 8 slots

El Perfil de Aluminio PG20 con una ranura tipo T de 6mm se utiliza para la construcción de ensamblajes modulares livianos.
Strut profile PG20 featuring 6mm T-slot is designed for constructing light weight assemblies.

20x20 4 slots

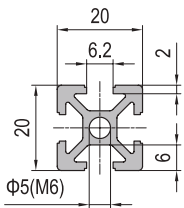

20x40 6 slots

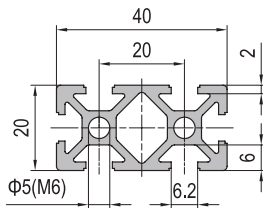

20x60 8 slots

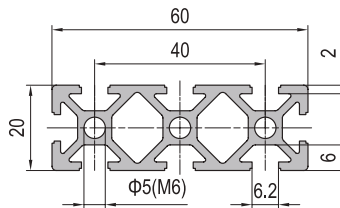

20x80 10 slots

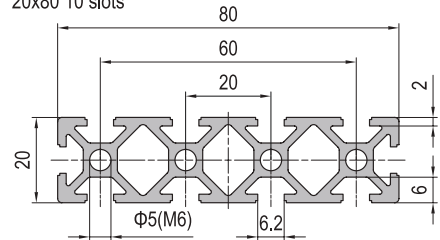

40x40 8 slots

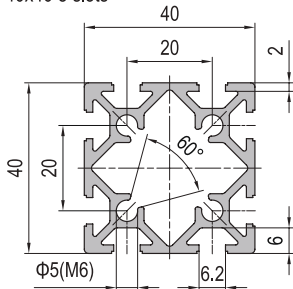

Selección del tipo de conector / Connector Selection



Die Cast Bracket 3.21



Angle Profile Bracket 3.31



linear bar connector 3.51



Inner Bracket 3.41

Descripción	Momento de Inercia Ix (cm ⁴)	Momento de Inercia Iy (cm ⁴)	Momento Resistente Wx (cm ³)	Momento Resistente Wy (cm ³)	Masa (kg/m)	Part No.
Strut Profile PG20 20x20 4 slots	0.8	0.8	0.8	0.8	0.5	1.11.20.020020.04
Strut Profile PG20 20x40 6 slots	1.4	5.1	1.4	2.5	0.9	1.11.20.020040.06
Strut Profile PG20 20x60 8 slots	2.0	15.8	2.0	5.3	1.3	1.11.20.020060.08
Strut Profile PG20 20x80 10 slots	2.6	35.9	2.6	9.0	1.7	1.11.20.020080.10
Strut Profile PG20 40x40 8 slots	8.9	8.9	4.5	4.5	1.3	1.11.20.040040.08

Perfil de Aluminio PG30

Strut Profile PG30

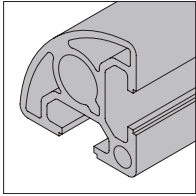

30x30 R90 2 slots

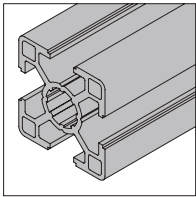

30x30 4 slots Light

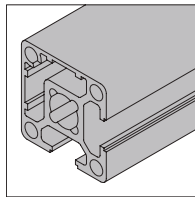

30x30 2 slots Type A

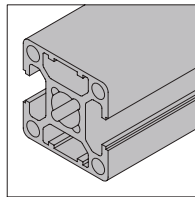

30x30 2 slots Type B

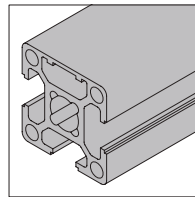

30x30 3 slots

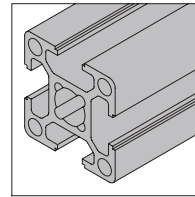

30x30 4 slots

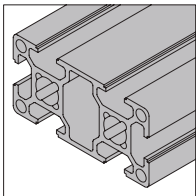

30x60 6 slots

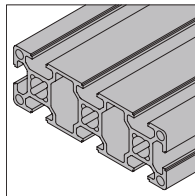

30x90 8 slots

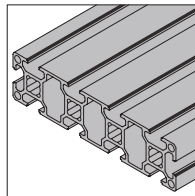

30x120 10 slots

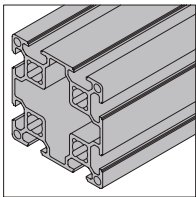

60x60 8 slots

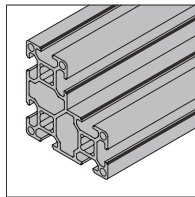

60x60 L 8 slots

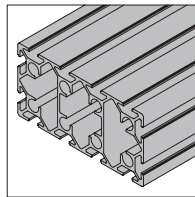

60x120 12 slots

El Perfil de Aluminio PG30 con una ranura tipo T de 8mm se utiliza para la construcción de ensamblajes modulares de mediano porte como ser: carros, estaciones de trabajo, cerramientos livianos, etc. También se encuentra disponible el perfil con radio 90° que permite la construcción de equipos más atractivos.
Strut profile PG30 featuring 8mm T-slot is designed for constructing medium weight assemblies such as machine frame structure, trolley, work station, partition and display frames, etc.

Selección del tipo de conector / Connector Selection



Anchor Connectorast 3.11



Die Cast Bracket 3.21



Angle Profile Bracket 3.31



Inner Bracket 3.41



linear bar connector 3.51



Screw Connector 3.81

Perfil de Aluminio PG30

Strut Profile PG30

30x30 R90 2 slots

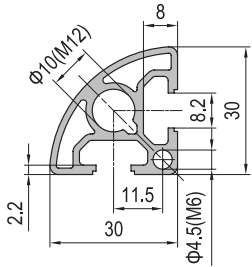

30x30 4 slots Light

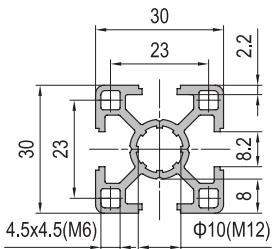

30x30 2 slots Type A

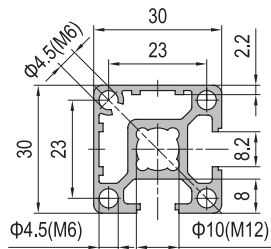

30x30 2 slots Type B

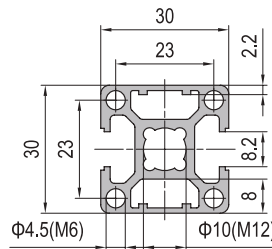

30x30 3 slots

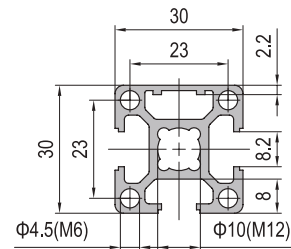

30x30 4 slots

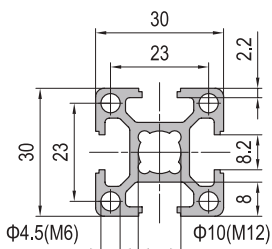

30x60 6 slots

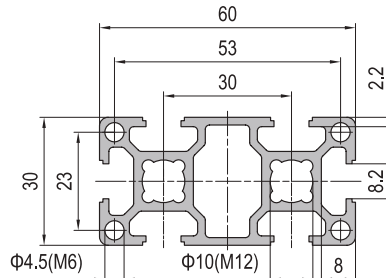

30x90 8 slots

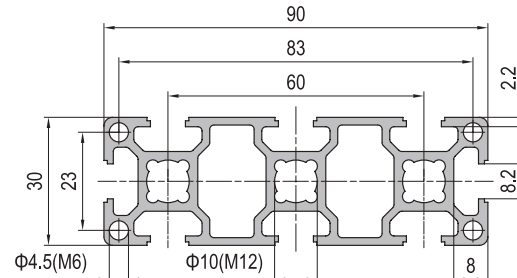

Descripción	Momento de Inercia Ix (cm ⁴)	Momento de Inercia Iy (cm ⁴)	Momento Resistente Wx (cm)	Momento Resistente Wy (cm)	Masa (kg/m)	Part No.
Strut Profile PG30 30x30 R90 2 slots	2.5	1.6	1.2	0.9	0.8	1.11.30.030030.R90.02
Strut Profile PG30 30x30 4 slots Light	2.6	2.6	1.8	1.8	0.8	1.11.30.030030.04L
Strut Profile PG30 30x30 2 slots Type A	2.9	2.9	2.0	2.0	0.9	1.11.30.030030.02A
Strut Profile PG30 30x30 2 slots Type B	2.8	3.2	1.9	2.1	0.9	1.11.30.030030.02B
Strut Profile PG30 30x30 3 slots	3.0	2.9	2.0	1.9	0.9	1.11.30.030030.03
Strut Profile PG30 30x30 4 slots	2.9	2.9	2.0	2.0	0.9	1.11.30.030030.04
Strut Profile PG30 30x60 6 slots	5.3	19.9	3.5	6.7	1.6	1.11.30.030060.06
Strut Profile PG30 30x90 8 slots	7.7	62.0	5.1	13.8	2.2	1.11.30.030090.08

Perfil de Aluminio PG30

Strut Profile PG30

30x120 10 slots

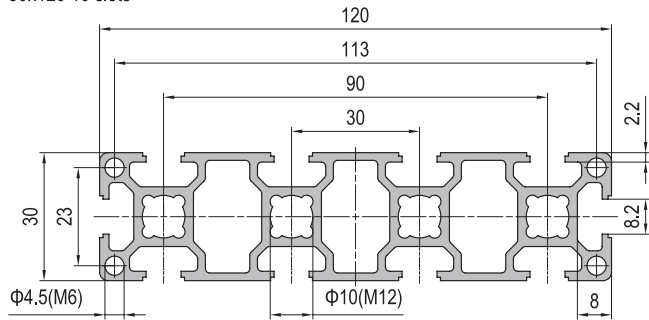

60x60 8 slots

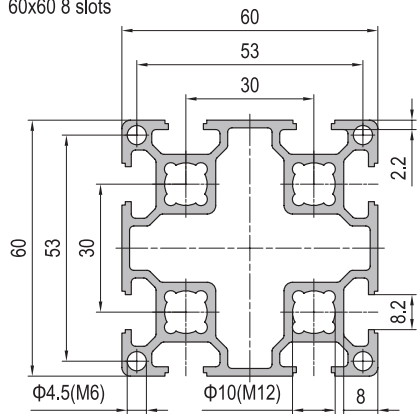

60x60 L 8 slots

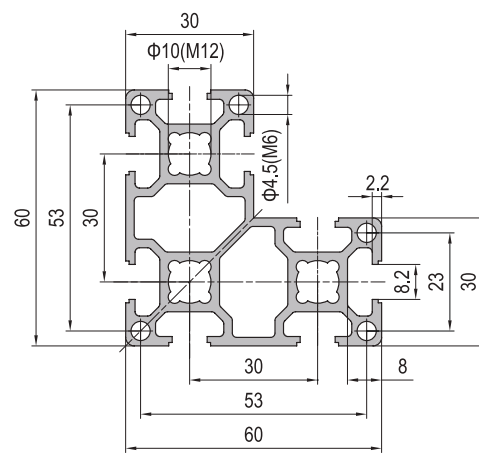

60x120 12 slots

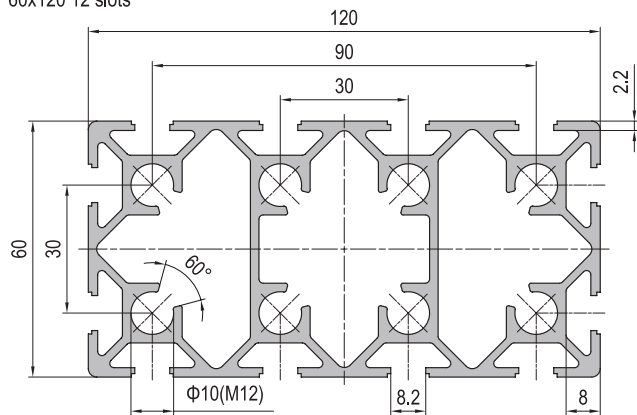

Descripción	Momento de Inercia Ix (cm ⁴)	Momento de Inercia Iy (cm ⁴)	Momento Resistente Wx (cm)	Momento Resistente Wy (cm)	Masa (kg/m)	Part No.
Strut Profile PG30 30x120 10 slots	10.1	139.9	6.7	23.3	2.9	1.11.30.030120.10
Strut Profile PG30 60x60 8 slots	35.3	35.3	11.8	11.8	2.5	1.11.30.060060.08
Strut Profile PG30 60x60 L 8 slots	35.2	17.6	8.5	5.0	2.3	1.11.30.060060L.08
Strut Profile PG30 60x120 12 slots	74.7	252.6	24.9	42.1	4.8	1.11.30.060120.12

Perfil de Aluminio PG40

Strut Profile PG40

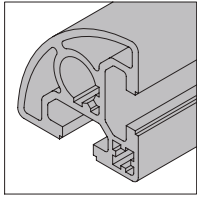

40x40 R90 2 slots

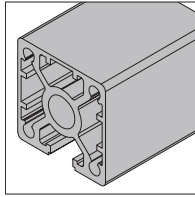

40x40 1 slots

El Perfil de Aluminio PG40 con una ranura tipo T de 10mm se utiliza para la construcción de ensamblajes modulares medianos y pesados como carros, estaciones de trabajo, estructuras para maquinaria, stands de exhibición, etc. Se trata de una opción de buenas prestaciones más económica que la línea PG45.

Strut profile PG40 featuring 10mm T-slot is designed for constructing medium or heavy weight assemblies, such as machine frame structure, trolley, work station, partition and display frames, etc. Profile PG40 offers an excellent performance and is more economical than PG45.

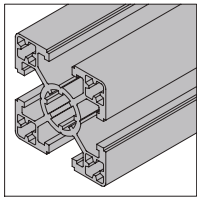

40x40 4 slots Super Light

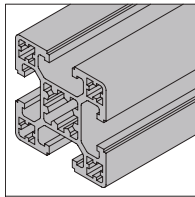

40x40 4 slots Light

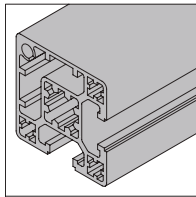

40x40 2 slots Type A

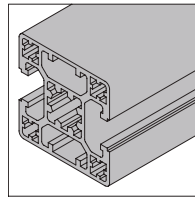

40x40 2 slots Type B

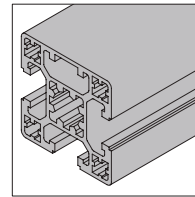

40x40 3 slots

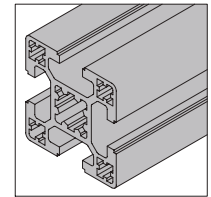

40x40 4 slots

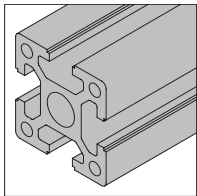

40x40 4 slots Heavy

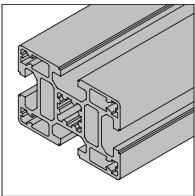

40x60 4 slots

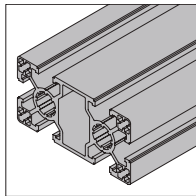

40x80 6 slots Super Light

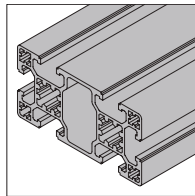

40x80 6 slots Light

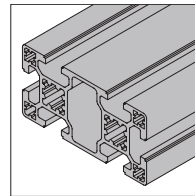

40x80 6 slots

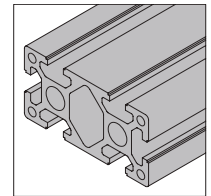

40x80 6 slots Heavy

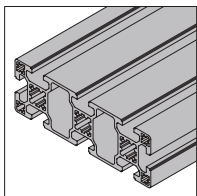

40x120 8 slots

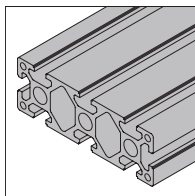

40x120 8 slots Heavy

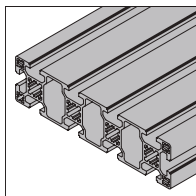

40x160 10 slots

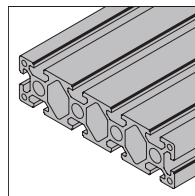

40x160 10 slots Heavy

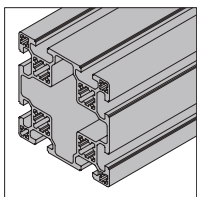

80x80 8 slots

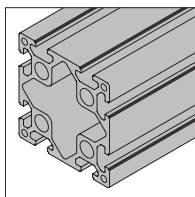

80x80 8 slots Heavy

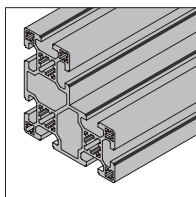

80x80 L 8 slots

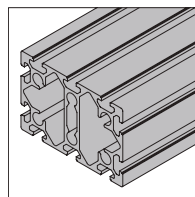

80x120 10 slots

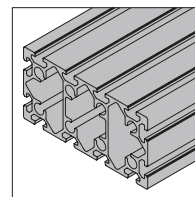

80x160 12 slots

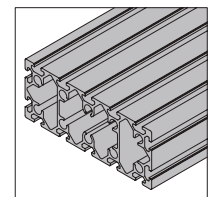

80x200 14 slots

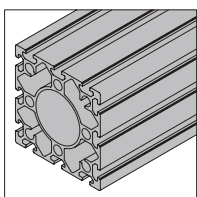

120x120 12 slots

Selección del tipo de conector / Connector Selection



Anchor Connectorast 3.11



Die Cast Bracket 3.21



Angle Profile Bracket 3.31



Inner Bracket 3.41



linear bar connector 3.51



Screw Connector 3.81

Perfil de Aluminio PG40

Strut Profile PG40

40x40 R90 2 slots

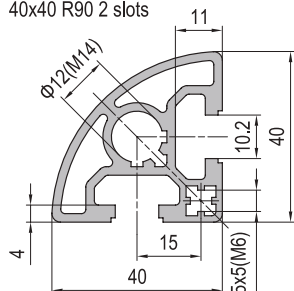

40x40 4 slots Super Light

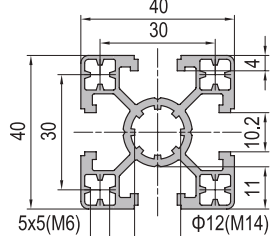

40x40 1 slot

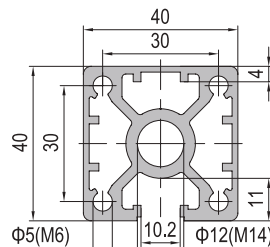

40x40 4 slots Light

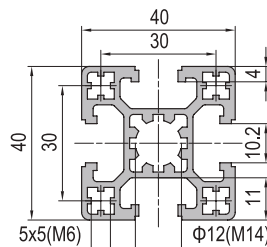

40x40 2 slots Type A

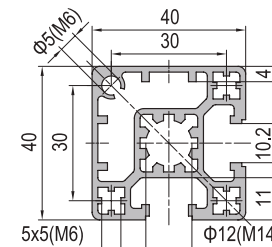

40x40 2 slots Type B

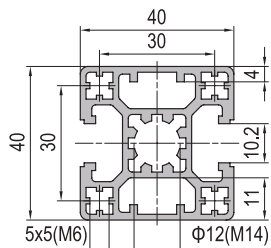

40x40 3 slots

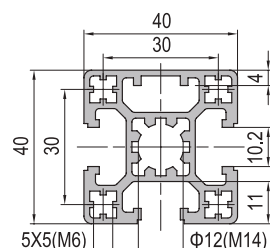

40x40 4 slots

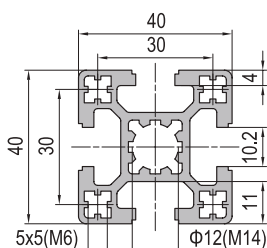

40x40 4 slots Heavy

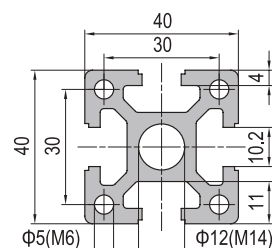

Descripción	Momento de Inercia Ix (cm ⁴)	Momento de Inercia Iy (cm ⁴)	Momento Resistente Wx (cm ³)	Momento Resistente Wy (cm ³)	Masa (kg/m)	Part No.
Strut Profile PG40 40x40 R90 2 slots	8.3	4.8	3.0	1.9	1.3	1.11.40.040040.R90.02
Strut Profile PG40 40x40 4 slots Super Light	7.3	7.3	3.6	3.6	1.3	1.11.40.040040.04SL
Strut Profile PG40 40x40 1 slot	10.4	10.1	5.2	5.0	1.68	1.11.40.040040.01
Strut Profile PG40 40x40 4 slots Light	8.6	8.6	4.3	4.3	1.5	1.11.40.040040.04L
Strut Profile PG40 40x40 2 slots Type A	9.6	9.6	4.5	4.5	1.5	1.11.40.040040.02A
Strut Profile PG40 40x40 2 slots Type B	9.6	8.6	4.8	4.3	1.5	1.11.40.040040.02B
Strut Profile PG40 40x40 3 slots	9.1	8.6	4.5	4.3	1.5	1.11.40.040040.03
Strut Profile PG40 40x40 4 slots	9.1	9.1	4.6	4.6	1.6	1.11.40.040040.04
Strut Profile PG40 40x40 4 slots Heavy	11.5	11.5	5.8	5.8	2.0	1.11.40.040040.04H

Perfil de Aluminio PG40
Strut Profile PG40

40x40 4 slots

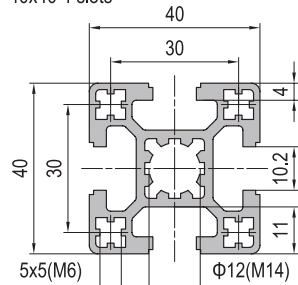

40x40 4 slots Heavy

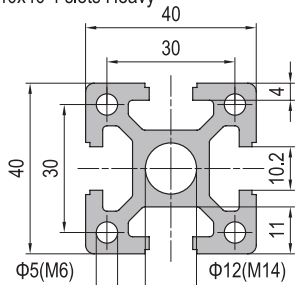

40x60 4 slots

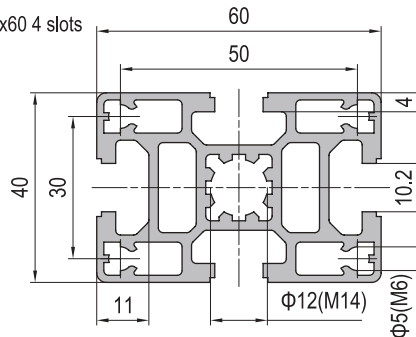

40x80 6 slots Super Light

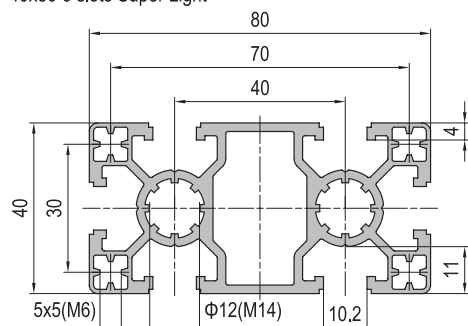

40x80 6 slots Light

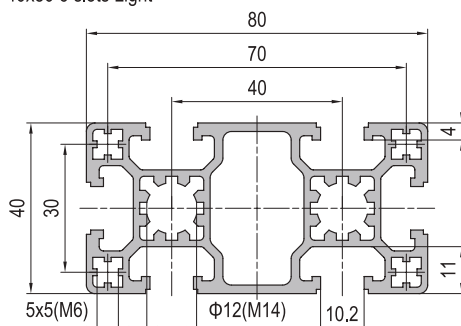

40x80 6 slots

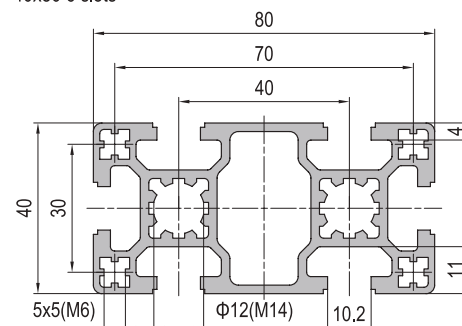

40x80 6 slots Heavy

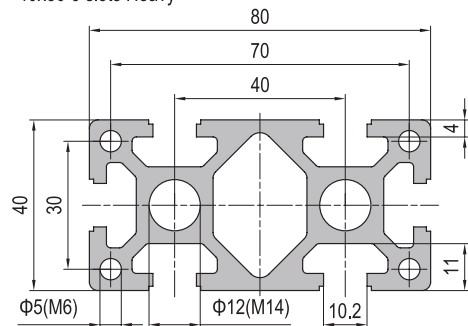

Descripción	Momento de Inercia Ix (cm ⁴)	Momento de Inercia Iy (cm ⁴)	Momento Resistente Wx (cm ³)	Momento Resistente Wy (cm ³)	Masa (kg/m)	Part No.
Strut Profile PG40 40x40 4 slots	9.1	9.1	4.6	4.6	1.6	1.11.40.040040.04
Strut Profile PG40 40x40 4 slots Heavy	11.5	11.5	5.8	5.8	2.0	1.11.40.040040.04H
Strut Profile PG40 40x60 4 slots	13.3	27.6	6.6	9.2	2.3	1.11.40.040060.04
Strut Profile PG40 40x80 6 slots Super Light	14.3	52.0	7.2	13.0	2.3	1.11.40.040080.06SL
Strut Profile PG40 40x80 6 slots Light	15.8	59.1	7.9	14.8	2.5	1.11.40.040080.06L
Strut Profile PG40 40x80 6 slots	16.6	63.2	8.3	15.8	2.7	1.11.40.040080.06
Strut Profile PG40 40x80 6 slots Heavy	22.2	80.8	11.1	20.2	3.6	1.11.40.040080.06H

Perfil de Aluminio PG40
Strut Profile PG40

40x120 8 slots

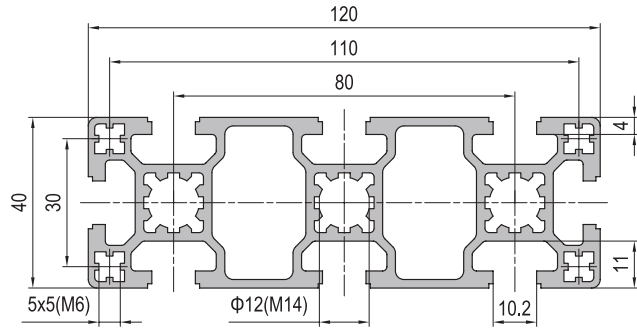

40x120 8 slots Heavy

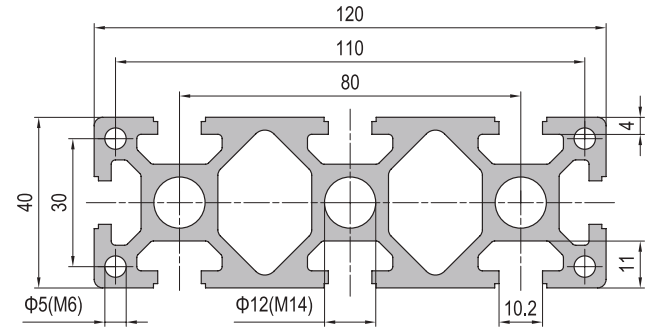

40x160 10 slots

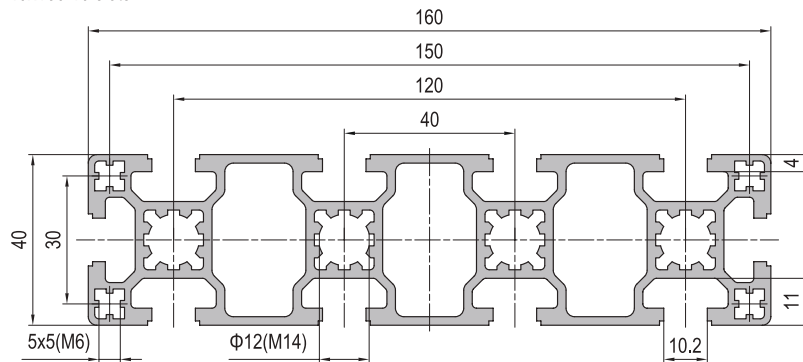

40x160 10 slots Heavy

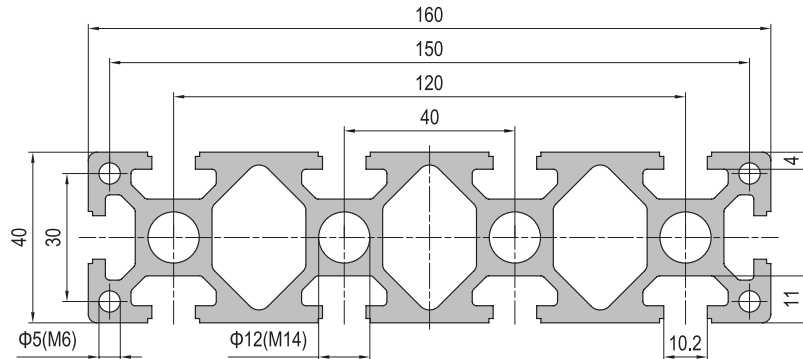

Descripción	Momento de Inercia I _x (cm ⁴)	Momento de Inercia I _y (cm ⁴)	Momento Resistente W _x (cm ³)	Momento Resistente W _y (cm ³)	Masa (kg/m)	Part No.
Strut Profile PG40 40x120 8 slots	24.1	194.8	12.1	32.5	3.8	1.11.40.040120.08
Strut Profile PG40 40x120 8 slots Heavy	33.0	255.3	16.5	42.6	5.2	1.11.40.040120.08H
Strut Profile PG40 40x160 10 slots	31.6	435.7	15.8	54.5	4.8	1.11.40.040160.10
Strut Profile PG40 40x160 10 slots Heavy	43.7	582.2	21.8	72.8	6.8	1.11.40.040160.10H

Perfil de Aluminio PG40

Strut Profile PG40

80x80 8 slots

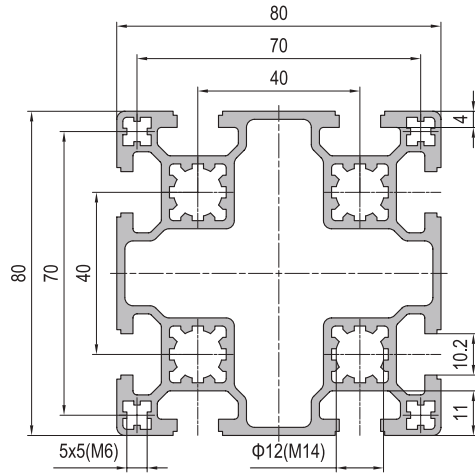

80x80 8 slots Heavy

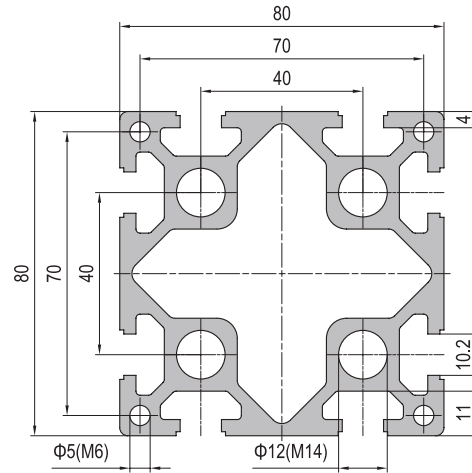

80x80 L 8 slots

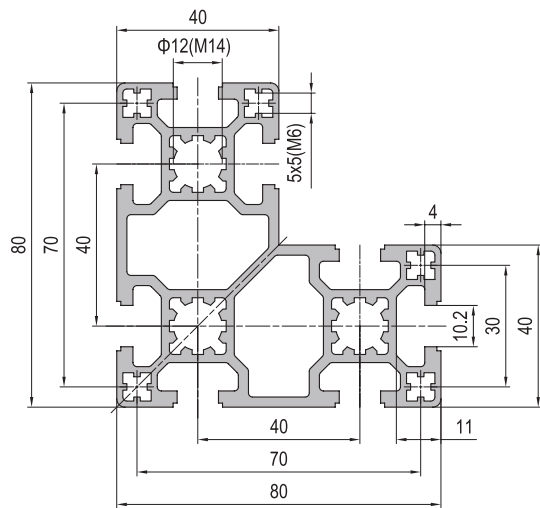

80x120 10 slots

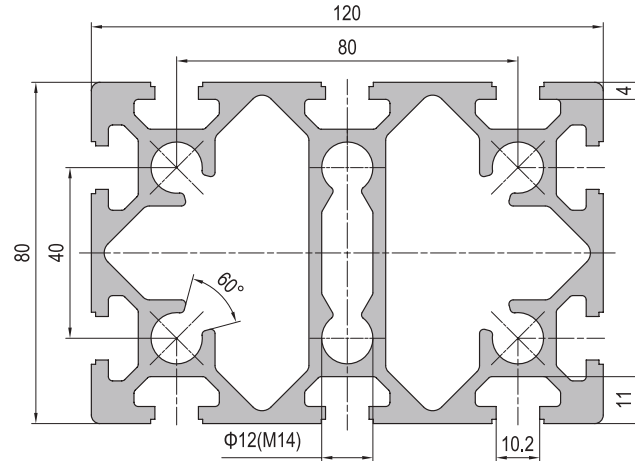

Descripción	Momento de Inercia Ix (cm ⁴)	Momento de Inercia Iy (cm ⁴)	Momento Resistente Wx (cm ³)	Momento Resistente Wy (cm ³)	Masa (kg/m)	Part No.
Strut Profile PG40 80x80 8 slots	109.9	109.9	27.5	27.5	4.2	1.11.40.080080.08
Strut Profile PG40 80x80 8 slots Heavy	148.2	148.2	37.1	37.1	5.7	1.11.40.080080.08H
Strut Profile PG40 80x80 L 8 slots	111.8	56.0	20.1	11.9	4.0	1.11.40.080080L.08
Strut Profile PG40 80x120 10 slots	222.1	449.2	55.5	74.8	8.3	1.11.40.080120.10

Perfil de Aluminio PG40

Strut Profile PG40

80x160 12 slots

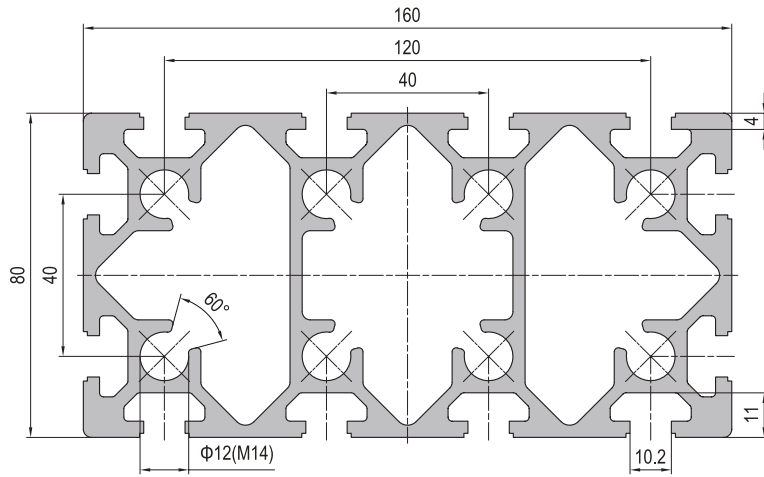

120x120 12 slots

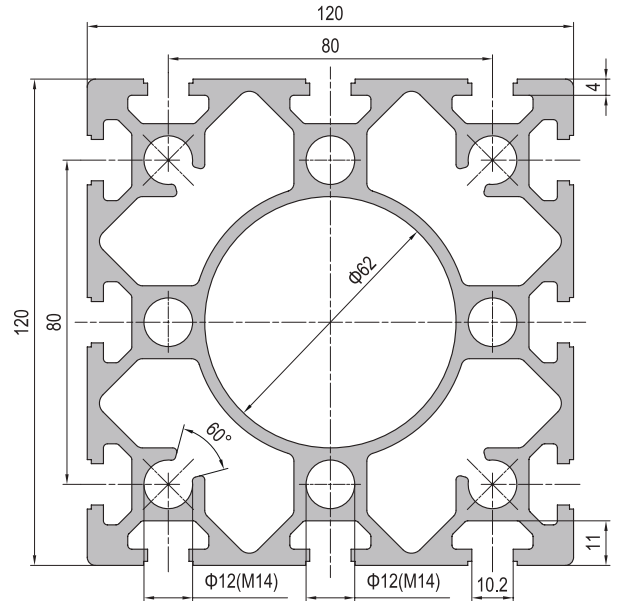

80x200 14 slots

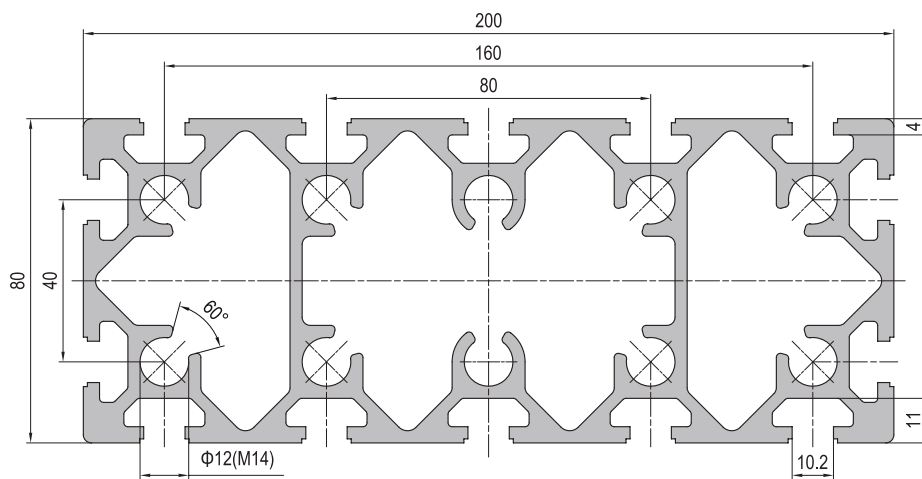

Descripción	Momento de Inercia Ix (cm ⁴)	Momento de Inercia Iy (cm ⁴)	Momento Resistente Wx (cm ³)	Momento Resistente Wy (cm ³)	Masa (kg/m)	Part No.
Strut Profile PG40 80x160 12 slots	287.5	975.5	71.9	121.9	10.4	1.11.40.080160.12
Strut Profile PG40 80x200 14 slots	353.1	1789.8	88.3	179.0	12.3	1.11.40.080200.14
Strut Profile PG40 120x120 12 slots	659.1	659.1	109.9	109.9	11.5	1.11.40.120120.12

Perfil de Aluminio PG45

Strut Profile PG45

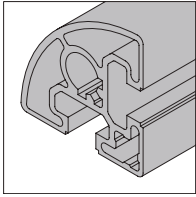

45x45 R90 2 slots

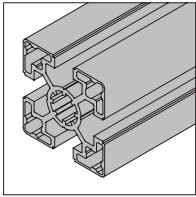

45x45 4 slots Light

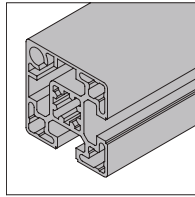

45x45 2 slots Type A

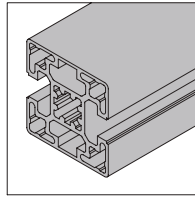

45x45 2 slots Type B

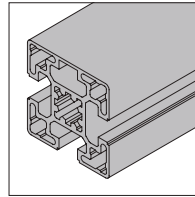

45x45 3 slots

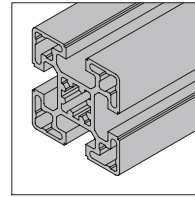

45x45 4 slots

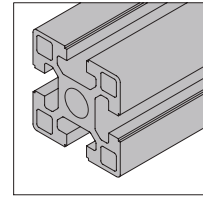

45x45 4 slots Heavy

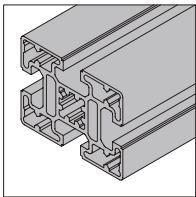

45x60 4 slots

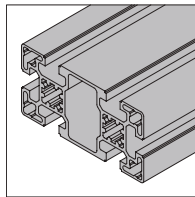

45x90 6 slots

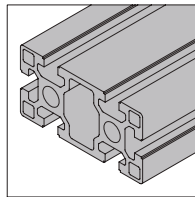

45x90 6 slots Heavy

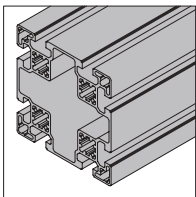

90x90 8 slots

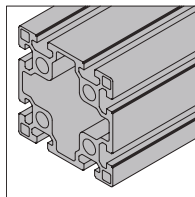

90x90 8 slots Heavy

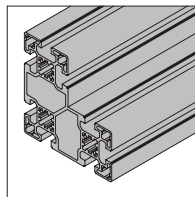

90x90 L 8 slots

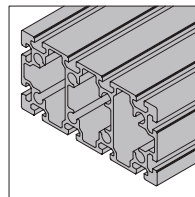

90x180 12 slots

El Perfil de Aluminio PG45 con una ranura tipo T de 10mm se utiliza para la construcción de ensamblajes modulares pesados como ser estructuras para máquinas, estaciones de trabajo, carros de trabajo, estanterías para stock de productos, etc.

Strut Profile PG45 featuring 10mm T-slot is designed for constructing heavy weight assemblies such as machine frame structure, trolley, work station, partition and display frames, etc.

Selección del tipo de conector / Connector Selection



Anchor Connectorast 3.11



Die Cast Bracket 3.21



Angle Profile Bracket 3.31



Inner Bracket 3.41



linear bar connector 3.51



Screw Connector 3.81

Perfil de Aluminio PG45

Strut Profile PG45

45x45 R90 2 slots

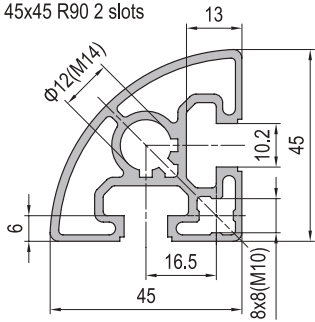

45x45 4 slots Light

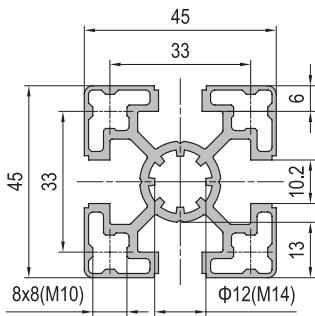

45x45 2 slots Type A

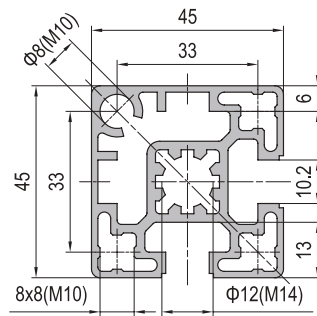

45x45 2 slots Type B

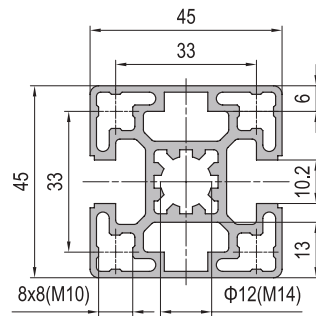

45x45 3 slots

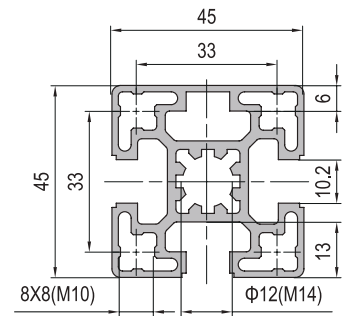

45x45 4 slots

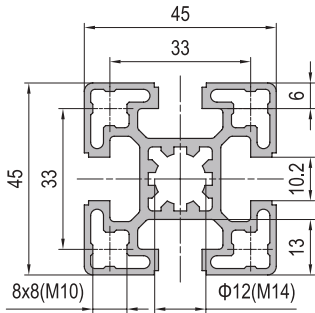

45x45 4 slots Heavy

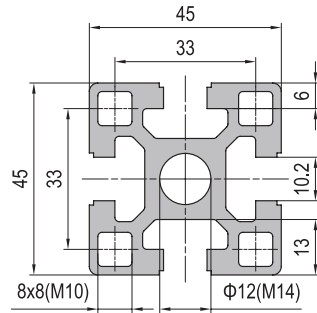

Descripción	Momento de Inercia Ix (cm ⁴)	Momento de Inercia Iy (cm ⁴)	Momento Resistente Wx (cm ³)	Momento Resistente Wy (cm ³)	Masa (kg/m)	Part No.
Strut Profile PG45 45x45 R90 2 slots	10.5	6.4	3.5	2.4	1.5	1.11.45.045045.R90.02
Strut Profile PG45 45x45 4 slots Light	10.5	10.5	4.7	4.7	1.6	1.11.45.045045.04L
Strut Profile PG45 45x45 2 slots Type A	12.9	12.9	5.7	5.7	1.9	1.11.45.045045.02A
Strut Profile PG45 45x45 2 slots Type B	13.7	12.1	6.1	5.4	1.9	1.11.45.045045.02B
Strut Profile PG45 45x45 3 slots	12.9	12.1	5.7	5.4	1.8	1.11.45.045045.03
Strut Profile PG45 45x45 4 slots	12.1	12.1	5.4	5.4	1.8	1.11.45.045045.04
Strut Profile PG45 45x45 4 slots Heavy	16.5	16.5	7.4	7.4	2.4	1.11.45.045045.04H

Perfil de Aluminio PG45

Strut Profile PG45

45x60 4 slots

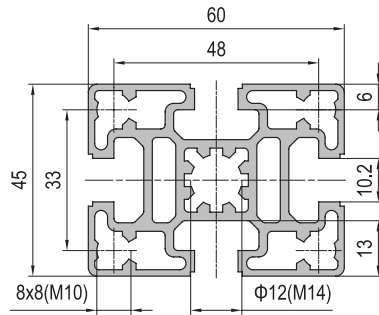

45x90 6 slots

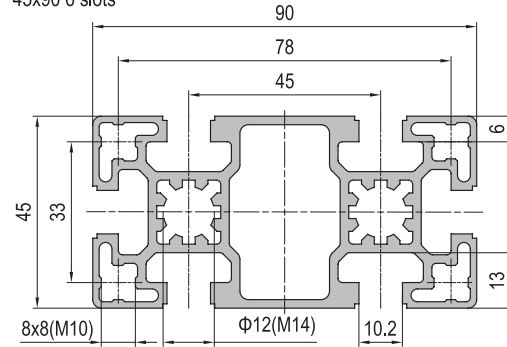

45x90 6 slots Heavy

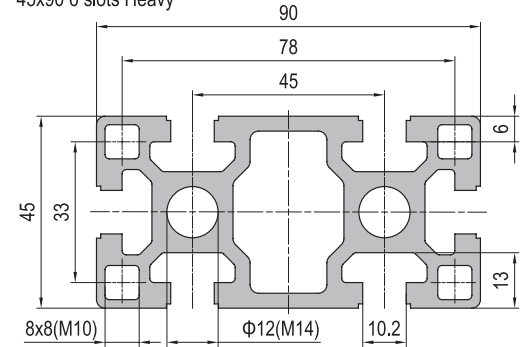

90x90 8 slots

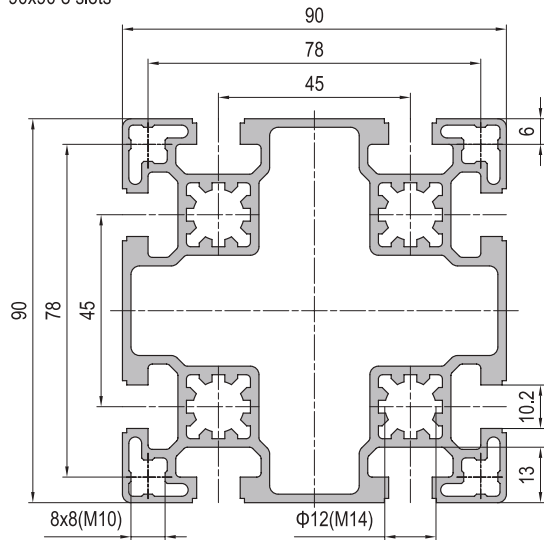

90x90 8 slots Heavy

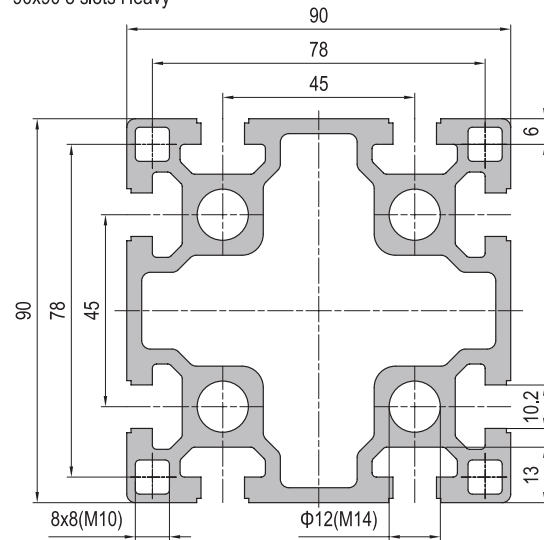

Descripción	Momento de Inercia Ix (cm ⁴)	Momento de Inercia Iy (cm ⁴)	Momento Resistente Wx (cm ³)	Momento Resistente Wy (cm ³)	Masa (kg/m)	Part No.
Strut Profile PG45 45x60 4 slots	16.2	27.8	7.2	9.3	2.4	1.11.45.045060.04
Strut Profile PG45 45x90 6 slots	24.2	89.3	10.8	19.9	3.2	1.11.45.045090.06
Strut Profile PG45 45x90 6 slots Heavy	32.5	122.2	14.5	27.2	4.4	1.11.45.045090.06H
Strut Profile PG45 90x90 8 slots	163.2	163.2	36.3	36.3	5.0	1.11.45.090090.08
Strut Profile PG45 90x90 8 slots Heavy	222.9	222.9	49.6	49.6	6.8	1.11.45.090090.08H

Perfil de Aluminio PG45

Strut Profile PG45

90x90 L 8 slots

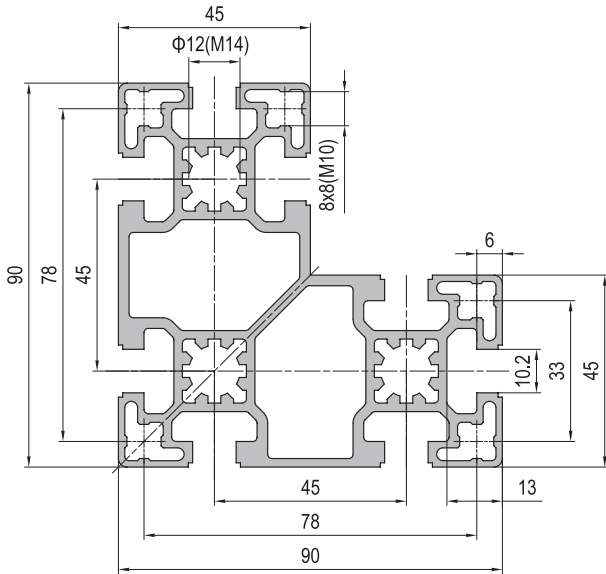

90x180 12 slots

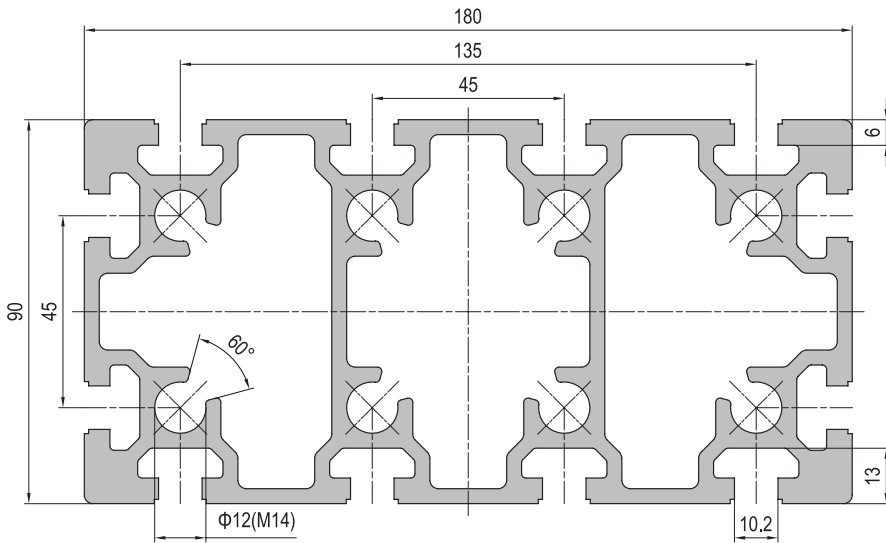

Descripción	Momento de Inercia Ix (cm ⁴)	Momento de Inercia Iy (cm ⁴)	Momento Resistente Wx (cm ³)	Momento Resistente Wy (cm ³)	Masa (kg/m)	Part No.
Strut Profile PG45 90x90 L 8 slots	161.4	80.3	25.6	15.2	4.6	1.11.45.090090L.08
Strut Profile PG45 90x180 12 slots	454.9	1585.7	101.1	176.2	12.7	1.11.45.090180.12

Perfil de Aluminio PG50

Strut Profile PG50

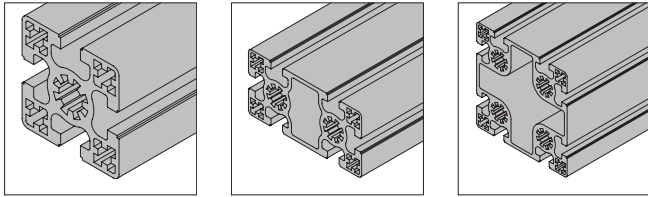

50x50 4 slots

50x100 6 slots

100x100 8 slots

El Perfil de Aluminio PG50 con una ranura tipo T de 10mm se utiliza para la construcción de ensamblajes modulares pesados.

Strut profile PG50 featuring 10mm T-slot is designed for constructing heavy weight assemblies.

50x50 4 slots

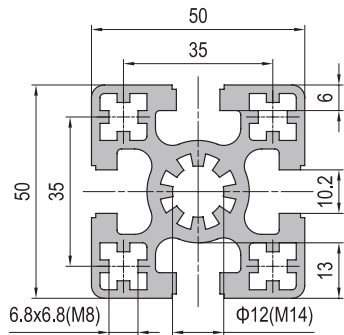

50x100 6 slots

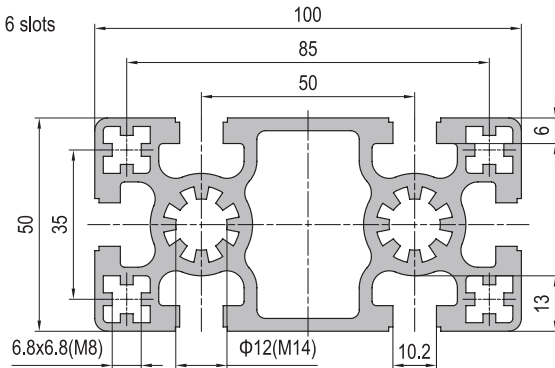

100x100 8 slots

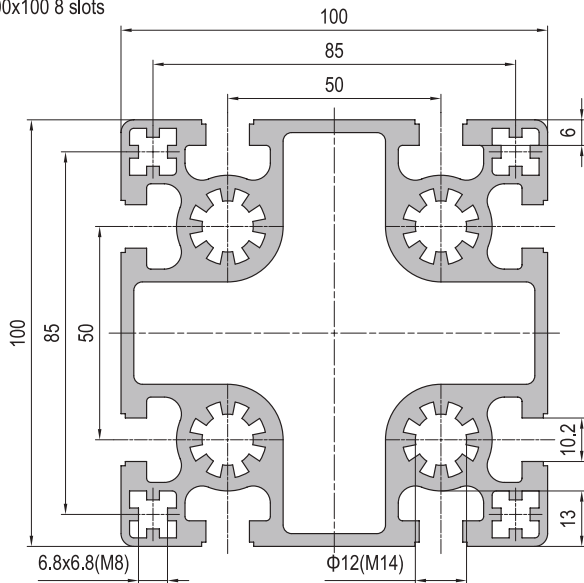

Selección del tipo de conector:



Angle Profile Bracket 3.31



Screw Connector 3.81

Descripción	Momento de Inercia Ix (cm ⁴)	Momento de Inercia Iy (cm ⁴)	Momento Resistente Wx (cm ³)	Momento Resistente Wy (cm ³)	Masa (kg/m)	Part No.
Strut Profile PG50 50x50 4 slots	25.0	25.0	10.0	10.0	3.0	1.11.50.050050.04
Strut Profile PG50 50x100 6 slots	46.2	184.4	18.5	36.9	5.0	1.11.50.050100.06
Strut Profile PG50 100x100 8 slots	331.1	331.1	66.2	66.2	8.5	1.11.50.100100.08

Perfil de Aluminio PG60

Strut Profile PG60

60x60 4 slots

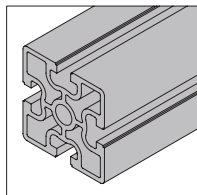

El Perfil de Aluminio PG60 con una ranura tipo T de 10mm se utiliza para la construcción de ensamblajes modulares pesados.
 Strut profile PG60 featuring 10mm T-slot is designed for constructing heavy weight assemblies.

60x60 4 slots

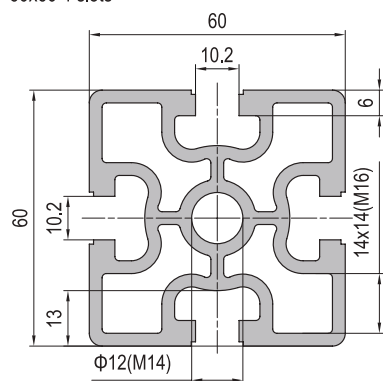

Selección del tipo de conector / Connector Selection



Angle Profile Bracket 3.31



Screw Connector 3.81

Descripción	Momento de Inercia Ix (cm ⁴)	Momento de Inercia Iy (cm ⁴)	Momento Resistente Wx (cm ³)	Momento Resistente Wy (cm ³)	Masa (kg/m)	Part No.
Strut Profile PG60 60x60 4 slots	47.7	47.7	15.9	15.9	3.8	1.11.60.060060.04

Perfiles Ángulo

Angle Profile

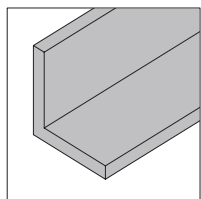

Angle Profile 20x20x3

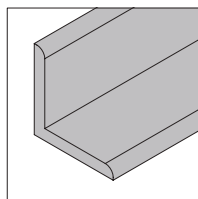

Angle Profile 30x30x4

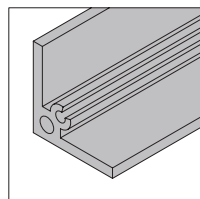

Angle Profile 35x35x4

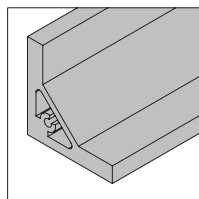

Angle Profile 50x50x9

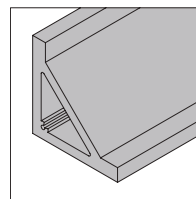

Angle Profile 100x100x15

Los Perfiles Ángulo son utilizados para la generación de perfiles de conexión angulares. También son utilizados para una variedad de soluciones debido a su gran flexibilidad. La superficie del perfil puede tener diferentes terminaciones, como ser anodizado natural, anodizado color negro, pintura electroforética, etc.

Angle profile is mainly used for angle bracket production. It has a wide range of applications due to its flexibility. The surface treatment of the finished product can be natural anodized, black anodized, black electrophoresis, etc.

Angle Profile 20x20x3

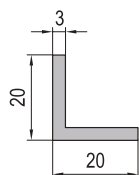

Angle Profile 30x30x4

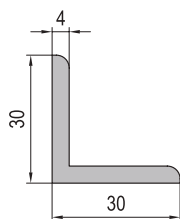

Angle Profile 35x35x4

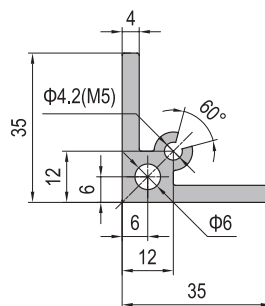

Angle Profile 50x50x9

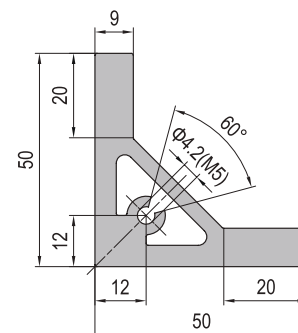

Angle Profile 100x100x15

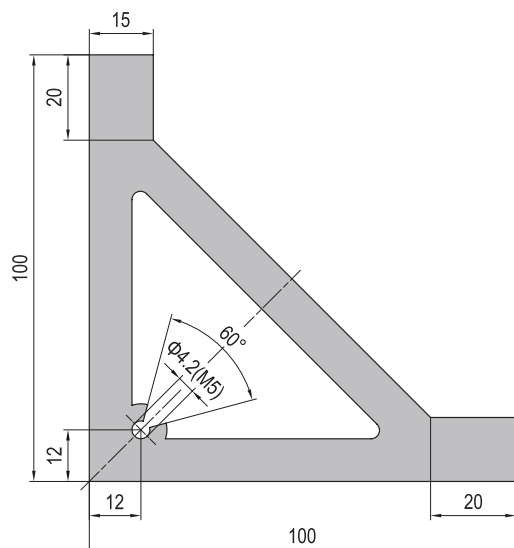

Descripción	Masa (kg/m)	Part No.
Angle Profile 20x20x3	0.3	1.31.2020.03
Angle Profile 30x30x4	0.6	1.31.3030.04
Angle Profile 35x35x4	0.9	1.31.3535.04
Angle Profile 50x50x9	2.3	1.31.5050.09
Angle Profile 100x100x15	8.5	1.31.100100.15

NOTE: El largo máximo del perfil ángulo 100x100x15 es 4000m.
 El resto de los perfiles ángulo tienen un largo estándar de 5800mm.

*Maximum length for angle profile 100x100x15 is 4000m.
 All others have a standard length of 5800mm.*

Perfiles Especiales

Special Profile

Los perfiles para canalización eléctrica poseen ranuras tipo T que permite la conexión rápida y sencilla a la estructura de la máquina.
Conduit profiles for electrical installations have a T slot that allows quick and easy fixation to the machine structure.

Conduit Profile-40x40

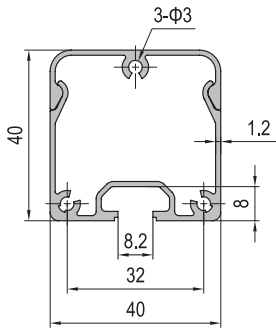

Conduit Profile-40x80

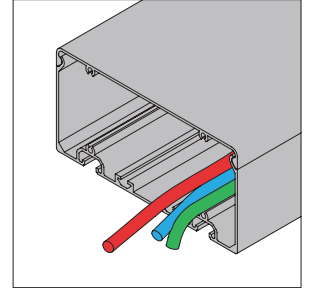
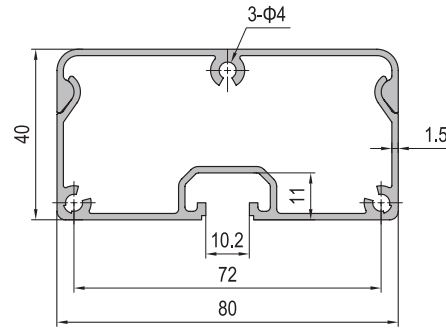

Conduit Profile-60x120

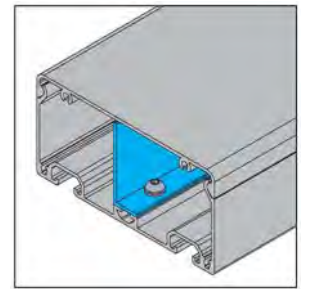
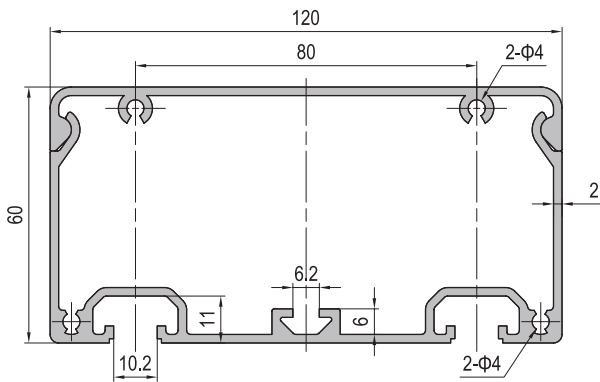

Partition profile-16x48

Conduit Profile-80x160

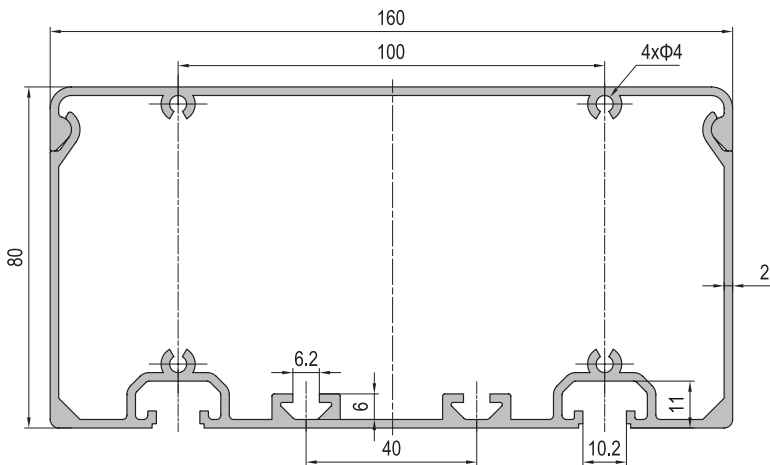

Descripción	Masa (kg/m)	Part No.
Conduit Profile 40x40	0.82	1.41.40.040040
Conduit Profile 40x80	1.41	1.41.40.040080
Conduit Profile 60x120	2.80	1.41.60.060120
Conduit Profile 80x160	3.64	1.41.40.080160
Conduit Profile 80x200	4.89	1.41.40.080200
Partition profile 16x48	0.35	1.31.1648.02



2.11-2.51

Tuerca tipo "Pre-set"
Pre-set Nut

Camisa de Posición para
Tuerca tipo "Pre-Set"
*Locating Sleeve for
Pre-set Nut*

Tuerca Cuadrada
Square Nut

Tuerca tipo T
T Nut

Tuerca para Igualar Potencial
Potential Equaliser Nut

Tuerca tipo "Subsequent"
Subsequent Nut

Tuerca Anti-Torsión
Anti-Torsion Subsequent Nut

Perno tipo T
T Bolt

2

Elementos de Fijación *Fastening Elements*

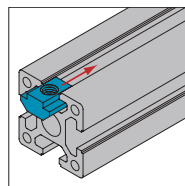

2.11.01

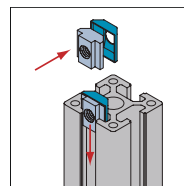

2.11.02

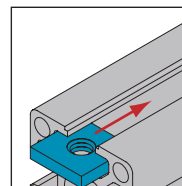

2.12.01

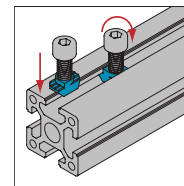

2.21.01

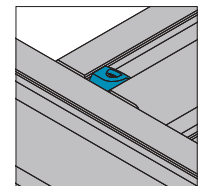

2.22.01

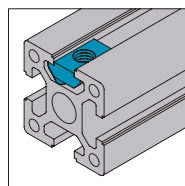

2.31.01

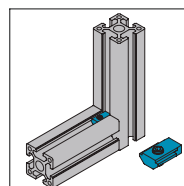

2.32.01

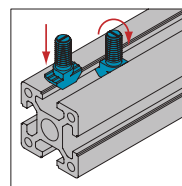

2.41.01

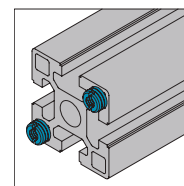

2.51.01

Elementos de Fijación

Fastening Elements

Tuerca tipo "Pre-set"

Pre-set Nut

La Tuerca tipo "Pre-set" puede ser colocada en la ranura tipo T sólo desde el extremo del perfil.

The Pre-set Nut can only be inserted from the profile end.

Material: Acero niquelado / Nickel plated steel

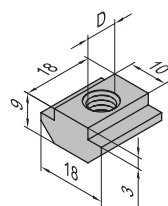
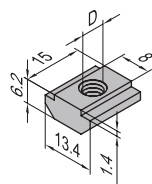
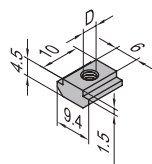
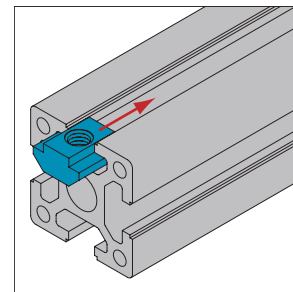

Descripción	D	Material	Masa (g/pcs)	Part No.
Pre-set Nut-6-M4	M4	nickel plated steel	3	2.11.06.M4
Pre-set Nut-6-M5	M5	nickel plated steel	3	2.11.06.M5

Descripción	D	Material	Masa (g/pcs)	Part No.
Pre-set Nut-8-M4	M4	nickel plated steel	8	2.11.08.M4
Pre-set Nut-8-M5	M5	nickel plated steel	8	2.11.08.M5
Pre-set Nut-8-M6	M6	nickel plated steel	8	2.11.08.M6

Descripción	D	Material	Masa (g/pcs)	Part No.
Pre-set Nut-10-M4	M4	nickel plated steel	16	2.11.10.M4
Pre-set Nut-10-M5	M5	nickel plated steel	16	2.11.10.M5
Pre-set Nut-10-M6	M6	nickel plated steel	16	2.11.10.M6
Pre-set Nut-10-M8	M8	nickel plated steel	16	2.11.10.M8

Elementos de Fijación
Fastening Elements

Camisa de Posición para Tuerca tipo "Pre-set"
Locating Sleeve for Pre-set Nut

La Camisa de Posición para Tuerca tipo "Pre-set" se utiliza para evitar que la misma no deslice a través de la ranura tipo T del perfil una vez que fue colocada en la posición deseada. Es especialmente útil en ensamblajes que requieren ubicar la tuerca en posición vertical.

The Locating Sleeve for Pre-set Nut is used to fix the position and avoid the nut to slide particularly when having the profile in vertical position.

Material: EVA

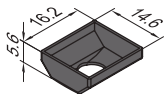
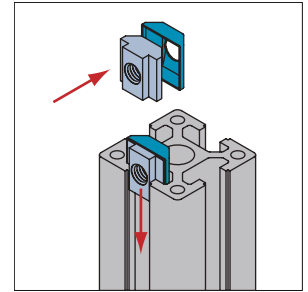

Descripción	Material	Masa (g/pcs)	Part No.
Pre-set Nut Sleeve-8	EVA	0.3	2.11.08.01

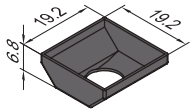

Descripción	Material	Masa (g/pcs)	Part No.
Pre-set Nut Sleeve-10	EVA	0.4	2.11.10.01

Elementos de Fijación

Fastening Elements

Tuerca Cuadrada Square Nut

La Tuerca Cuadrada puede ser colocada en la ranura tipo T sólo desde el extremo del perfil.
The Square Nut can only be inserted from the profile end.

Material: Acero al carbono zincado / *Zinc plated steel*

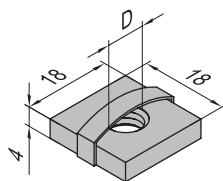
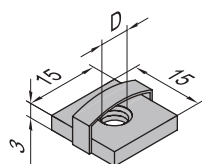
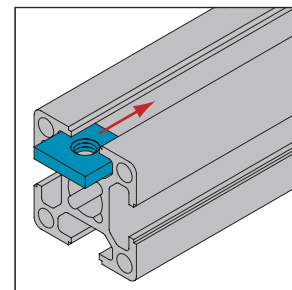

Descripción	D	Material	Masa (g/pcs)	Part No.
Square Nut-8-M4	M4	zinc plated steel	5	2.12.08.M4
Square Nut-8-M5	M5	zinc plated steel	5	2.12.08.M5
Square Nut-8-M6	M6	zinc plated steel	5	2.12.08.M6

Descripción	D	Material	Masa (g/pcs)	Part No.
Square Nut-10-M4	M4	zinc plated steel	9	2.12.10.M4
Square Nut-10-M5	M5	zinc plated steel	9	2.12.10.M5
Square Nut-10-M6	M6	zinc plated steel	9	2.12.10.M6
Square Nut-10-M8	M8	zinc plated steel	9	2.12.10.M8

Elementos de Fijación

Fastening Elements

Tuerca tipo T

T Nut

La Tuerca tipo "T-Nut" puede ser colocada en la ranura tipo T desde cualquier zona del perfil.

T Nut can be inserted in any position of the T Slot.

Material: Acero al carbono niquelado / Nickel plated steel

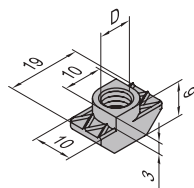
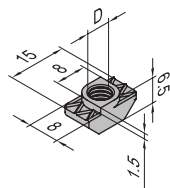
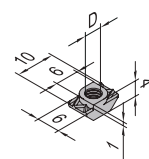
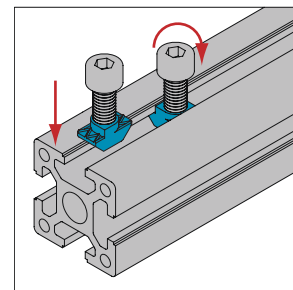

Descripción	D	Material	Masa (g/pcs)	Part No.
T Nut-6-M4	M4	nickel plated steel	2	2.21.06.M4
T Nut-6-M5	M5	nickel plated steel	2	2.21.06.M5

Descripción	D	Material	Masa (g/pcs)	Part No.
T Nut-8-M4	M4	nickel plated steel	4	2.21.08.M4
T Nut-8-M5	M5	nickel plated steel	4	2.21.08.M5
T Nut-8-M6	M6	nickel plated steel	3	2.21.08.M6

Descripción	D	Material	Masa (g/pcs)	Part No.
T Nut-10-M4	M4	nickel plated steel	8	2.21.10.M4
T Nut-10-M5	M5	nickel plated steel	8	2.21.10.M5
T Nut-10-M6	M6	nickel plated steel	7	2.21.10.M6
T Nut-10-M8	M8	nickel plated steel	6	2.21.10.M8

Elementos de Fijación

Fastening Elements

Tuerca para Igualar Potencial Potential Equaliser Nut

La Tuerca para Igualar Potencial se coloca girada 45° en la ranura T del perfil de aluminio. El prisionero se rosca contra la unión de ambos perfiles para desbastar la capa anódica y crear una conexión que permite conducir electricidad. De esta forma se puede asegurar que las posibles cargas eléctricas que existan en los perfiles individuales queden balanceadas.

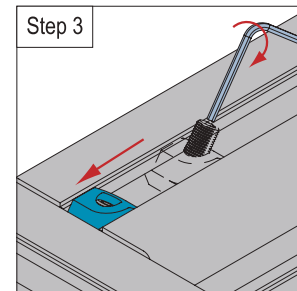
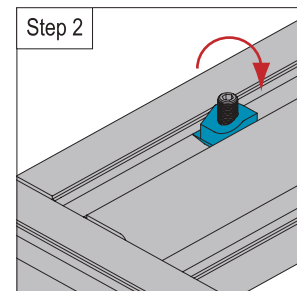
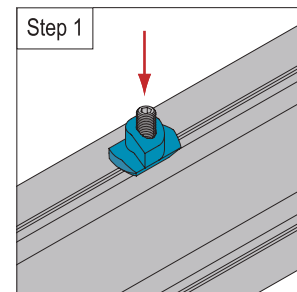
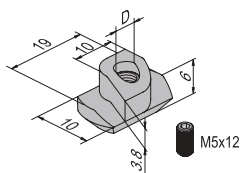
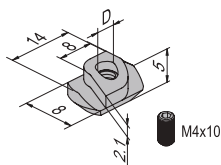
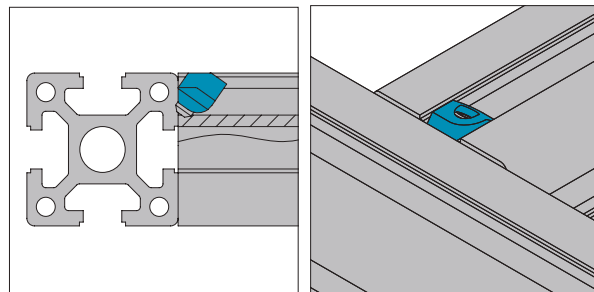

Descripción	D	Material	Masa (g/pcs)	Part No.
Potential Equaliser Nut-8-M4 (with top thread)	M4	diecast zinc	3	2.22.08.M4
Potential Equaliser Nut-10-M5 (with top thread)	M5	diecast zinc	7	2.22.10.M5

Elementos de Fijación

Fastening Elements

Tuerca tipo "Subsequent"
Subsequent Nut

La Tuerca tipo "Subsequent" puede ser colocada en la ranura tipo T desde cualquier zona del perfil con la característica adicional de la hoja de resorte que la mantiene en su posición.

Subsequent Nut can be inserted in any position of the T Slot. The spring assists with the assembly and positioning avoid the nut to slide.

Material: Acero al carbono zincado / Zinc plated steel

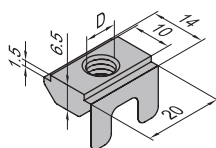
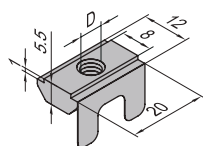
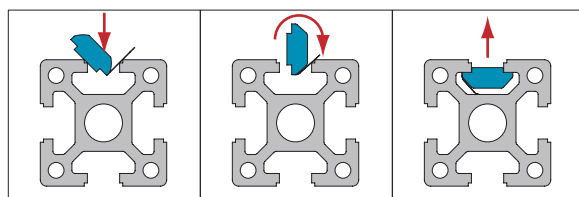
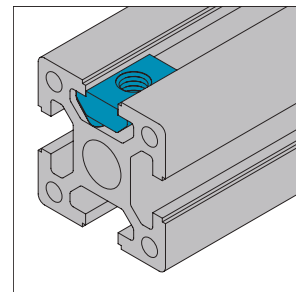

Descripción	D	Material	Masa (g/pcs)	Part No.
Subsequent Nut -8-M4	M4	zinc plated steel	5	2.31.08.M4
Subsequent Nut -8-M5	M5	zinc plated steel	5	2.31.08.M5
Subsequent Nut -8-M6	M6	zinc plated steel	5	2.31.08.M6
Subsequent Nut -8-M8	M8	zinc plated steel	5	2.31.08.M8

Descripción	D	Material	Masa (g/pcs)	Part No.
Subsequent Nut -10-M4	M4	zinc plated steel	8	2.31.10.M4
Subsequent Nut -10-M5	M5	zinc plated steel	8	2.31.10.M5
Subsequent Nut -10-M6	M6	zinc plated steel	8	2.31.10.M6
Subsequent Nut -10-M8	M8	zinc plated steel	8	2.31.10.M8

Elementos de Fijación

Fastening Elements

Tuerca tipo "Subsequent" anti-torsión
Anti-torsion Subsequent Nut

La Tuerca tipo "Subsequent" anti-torsión puede ser colocada en la ranura tipo T sólo desde el extremo del perfil y se utiliza para prevenir que la conexión entre dos perfiles pierda la escuadra.

Anti-torsion Subsequent Nut prevents profiles with screw connectors from torsion.

Material: Acero al carbono niquelado / *Nickel plated steel*

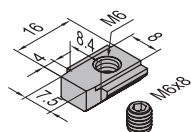
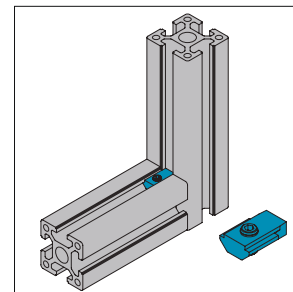

Descripción	Material	Masa (g/pcs)	Part No.
Anti-torsional Subsequent Nut-8 (with top thread)	nickel plated steel	10	2.32.08.M6

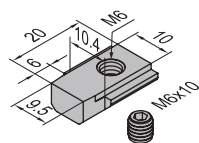

Descripción	Material	Masa (g/pcs)	Part No.
Anti-torsional Subsequent Nut-10 (with top thread)	nickel plated steel	15	2.32.10.M6

Elementos de Fijación

Fastening Elements

Perno tipo T

T Bolt

El Perno tipo T puede ser colocado en la ranura tipo T desde cualquier zona del perfil.

T Bolt can be inserted in any position of the T Slot.

Material: Acero al carbono niquelado / *Nickel plated steel*

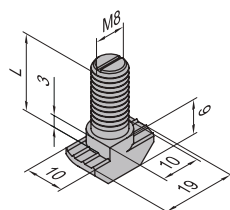
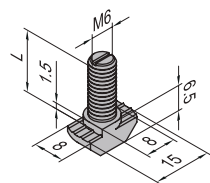
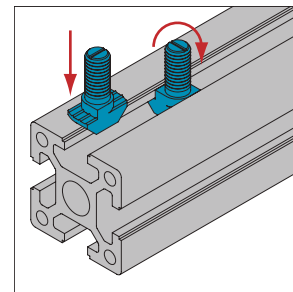

Descripción	L (mm)	Material	Masa (g/pcs)	Part No.
T Bolt-8-16	16	nickel plated steel	7	2.41.08.16
T Bolt-8-20	20	nickel plated steel	8	2.41.08.20
T Bolt-8-25	25	nickel plated steel	9	2.41.08.25

Descripción	L (mm)	Material	Masa (g/pcs)	Part No.
T Bolt-10-20	20	nickel plated steel	13	2.41.10.20
T Bolt-10-25	25	nickel plated steel	15	2.41.10.25
T Bolt-10-30	30	nickel plated steel	17	2.41.10.30

Elementos de Fijación

Fastening Elements

Perno Reductor de Diámetro
Hole Reducer Bolt

El Perno Reductor de Diámetro permite colocar un tornillo de menor medida que la del agujero existente.
Hole Reducer Bolt is used to reduce the diameter of the existing hole to fit any desired screw size.

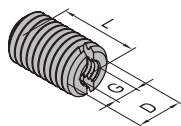

Descripción	D	G	L (mm)	Material	Masa (g/pcs)	Part No.
Hole Reducer Bolt-M10/M6	M10	M6	15	nickel plated steel	8	2.51.10.06
				zinc plated steel		2.52.10.06
Hole Reducer Bolt-M12/M6	M12	M6	20	nickel plated steel	11	2.51.12.06
				zinc plated steel		2.52.12.06
Hole Reducer Bolt-M14/M8	M14	M8	20	nickel plated steel	14	2.51.14.08
				zinc plated steel		2.52.14.08
Hole Reducer Bolt-M16/M8	M16	M8	20	nickel plated steel	19	2.51.16.08
				zinc plated steel		2.52.16.08

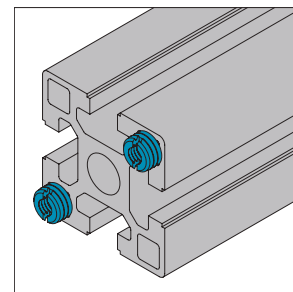

Hole Reducer Bolt M10/M6
 PG45 with square corner hole-8x8(M10)

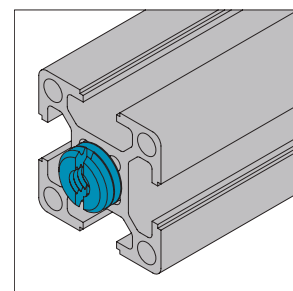

Hole Reducer Bolt M12/M6
 PG30 with core hole-Φ10(M12)

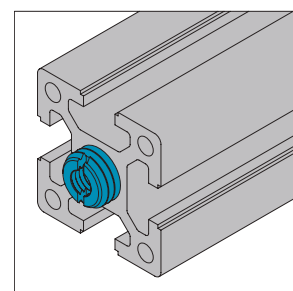

Hole Reducer Bolt M14/M8
 PG40/PG45/PG50/PG60 with core hole-Φ12(M14)

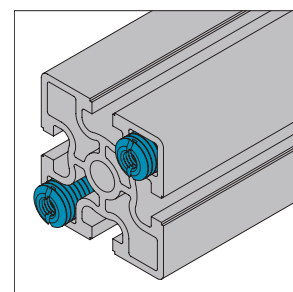

Hole Reducer Bolt M16/M8
 PG60 with square corner hole-14x14(M16)



3.11-3.92

Conector de Anclaje
Anchor Connector

Soporte de Fundición
Die Cast Bracket

Soporte de Perfil Ángulo
Angle Profile Bracket

Soporte Interior
Inner Bracket

Barra de Conexión
Linear Bar Connector

Platina de Unión
Joining Plate

Conector de Tope
Butt Connector

Conector de Extremo
End Connector

Conector de Tornillo
Screw Connector

Conector Cúbico
Cubic Connector

3

Elementos de Conexión *Connecting Elements*

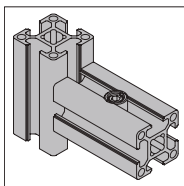

3.11

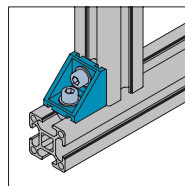

3.21

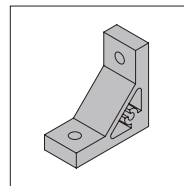

3.31

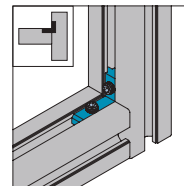

3.41.01

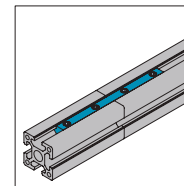

3.51.01

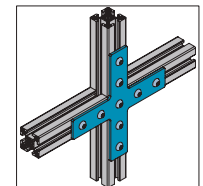

3.53.01

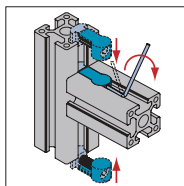

3.61.01

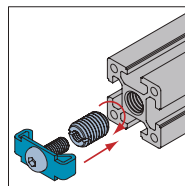

3.71.01

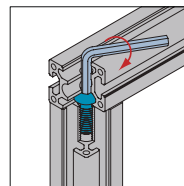

3.81.01

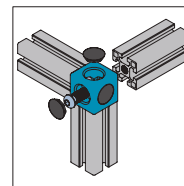

3.91.01

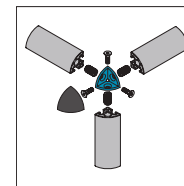

3.92.01

Elementos de Conexión
Connecting Elements

Conector de Anclaje
Anchor Connector



PG30-Universal

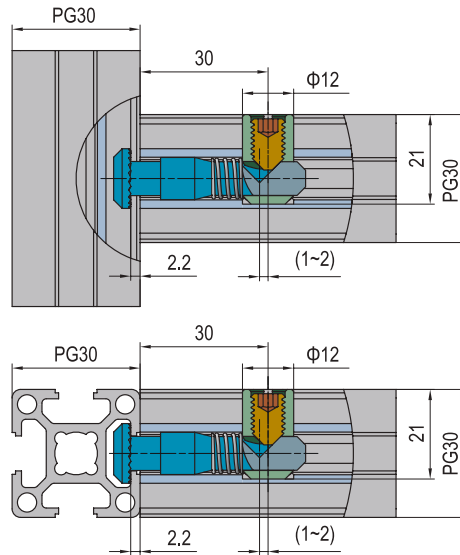
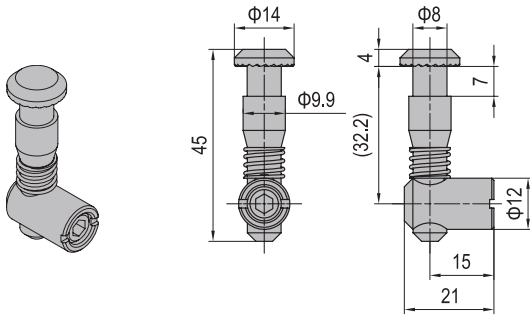

PG30-Standard (Model P)

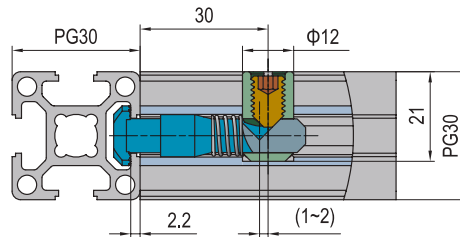
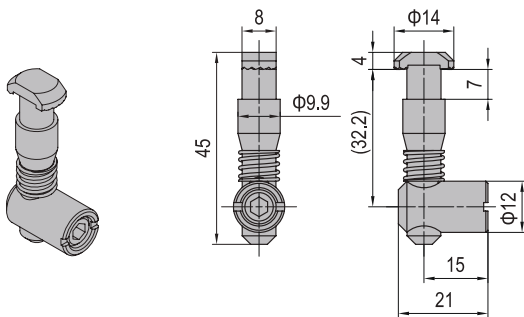

PG30-Standard (Model C)

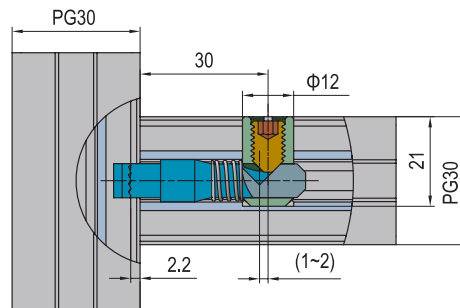
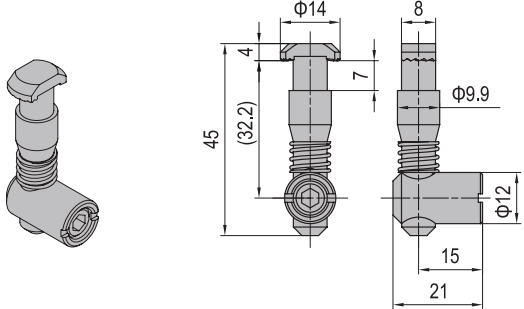

Descripción	Material	Masa (g/unit)	Part No.
Anchor Connector-PG30-Universal	zinc plated steel	39	3.11.30.01
Anchor Connector-PG30-Standard (Model P)	zinc plated steel	38	3.11.30.02
Anchor Connector-PG30-Standard (Model C)	zinc plated steel	38	3.11.30.03

Elementos de Conexión
Connecting Elements

Conector de Anclaje
Anchor Connector



PG30-Oblique (Model P)

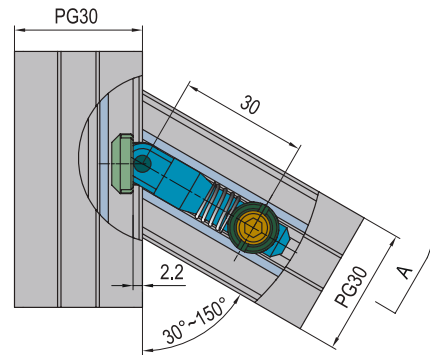
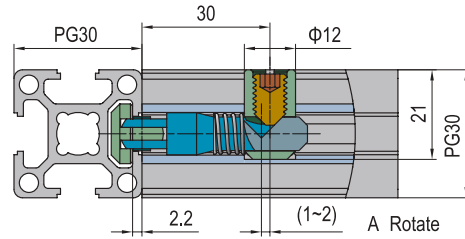
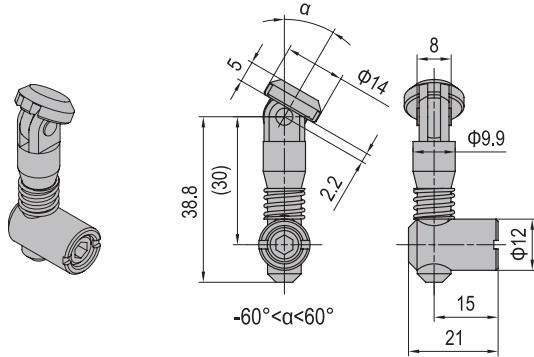

PG30-Oblique (Model C)

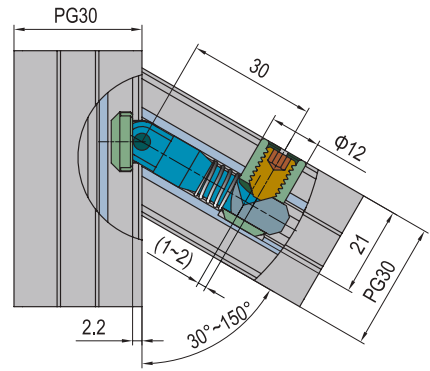
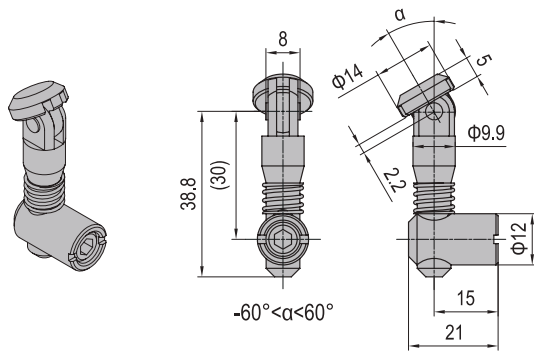

Descripción	Material	Masa (g/unit)	Part No.
Anchor Connector-PG30-Oblique (Model P)	zinc plated steel	55	3.11.30.04
Anchor Connector-PG30-Oblique (Model C)	zinc plated steel	55	3.11.30.05

Elementos de Conexión
Connecting Elements

Conector de Anclaje
Anchor Connector



PG30-Miter (Model P)

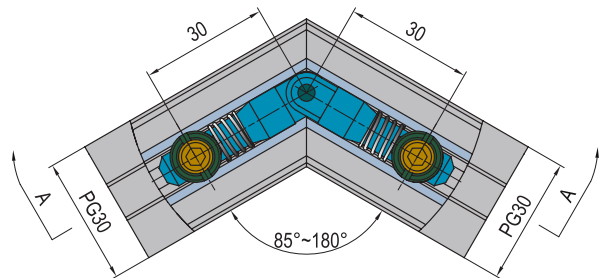
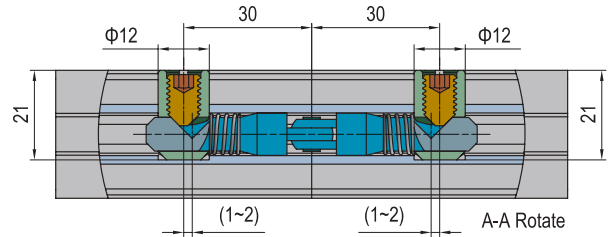
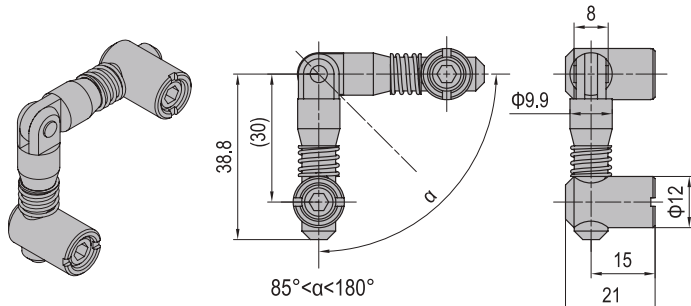

PG30-Miter (Model C)

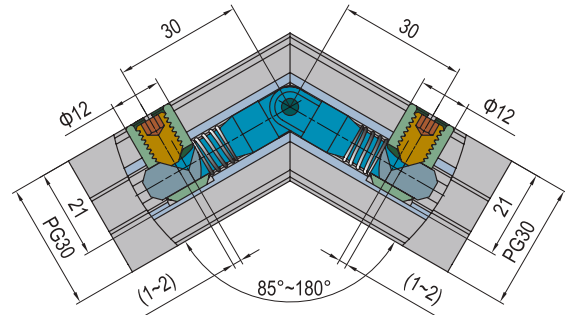
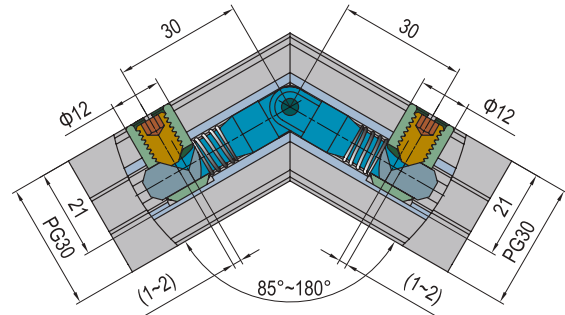
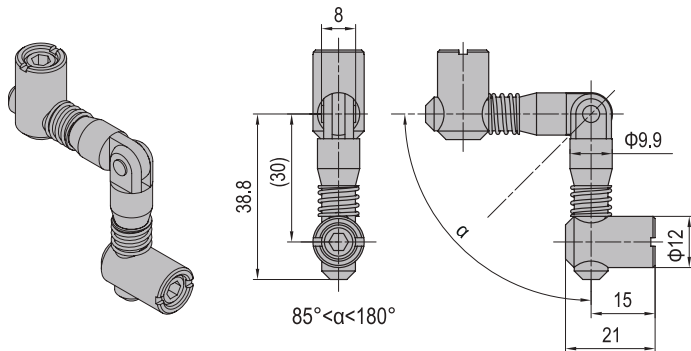

Descripción	Material	Masa (g/unit)	Part No.
Anchor Connector-PG30-Miter (Model P)	zinc plated steel	63	3.11.30.06
Anchor Connector-PG30-Miter (Model C)	zinc plated steel	63	3.11.30.07

Elementos de Conexión
Connecting Elements

Conector de Anclaje
Anchor Connector



PG40-Universal

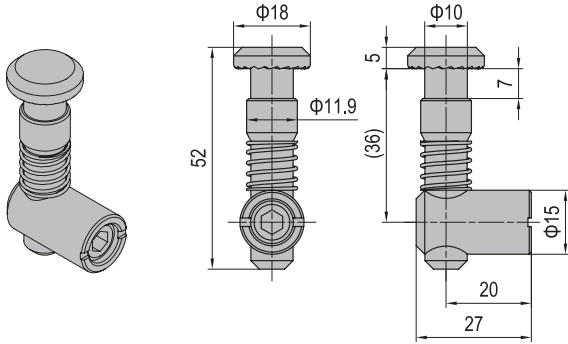

PG40-Standard (Model P)

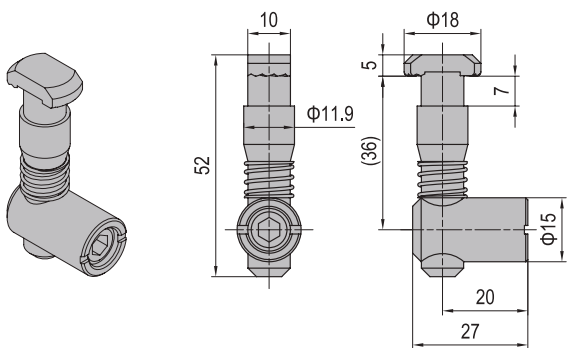

PG40-Standard (Model C)

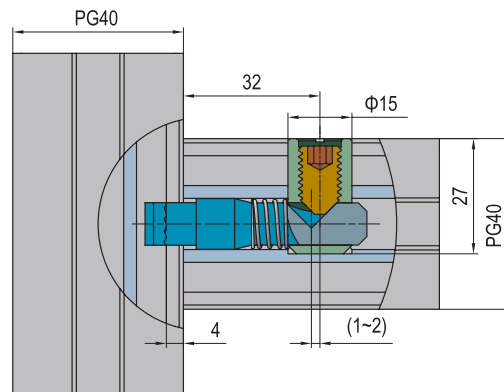
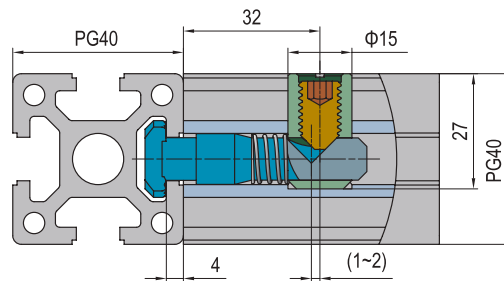
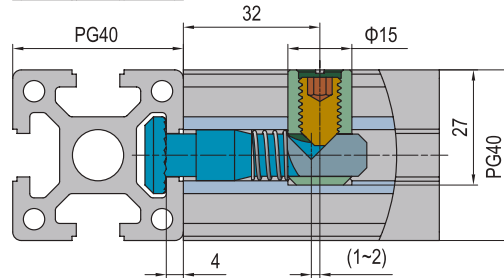
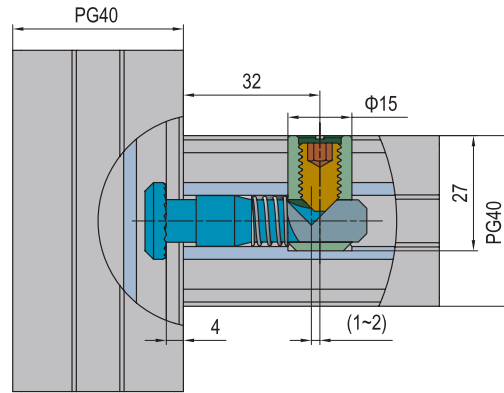
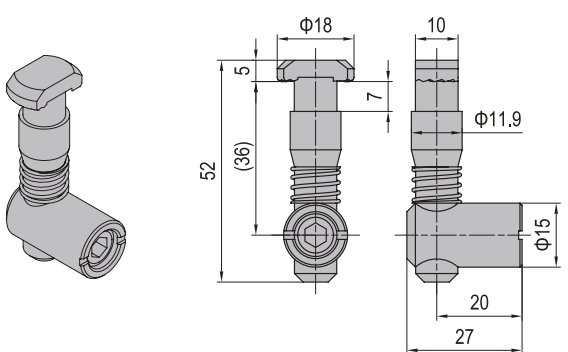

Descripción	Material	Masa (g/unit)	Part No.
Anchor Connector-PG40-Universal	zinc plated steel	62	3.11.40.01
Anchor Connector-PG40-Standard (Model P)	zinc plated steel	58	3.11.40.02
Anchor Connector-PG40-Standard (Model C)	zinc plated steel	58	3.11.40.03

Elementos de Conexión

Connecting Elements

Conector de Anclaje
Anchor Connector



PG40-Oblique (Model P)

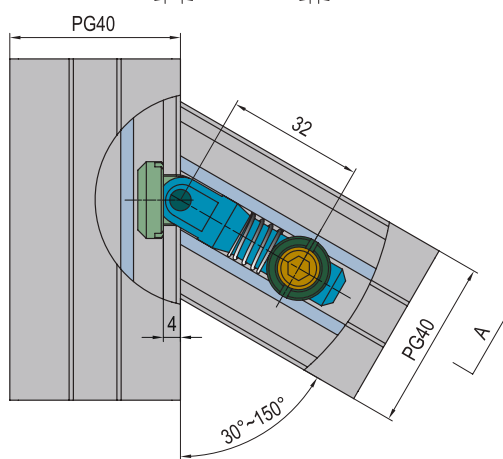
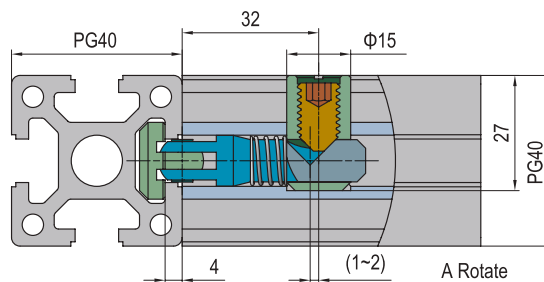
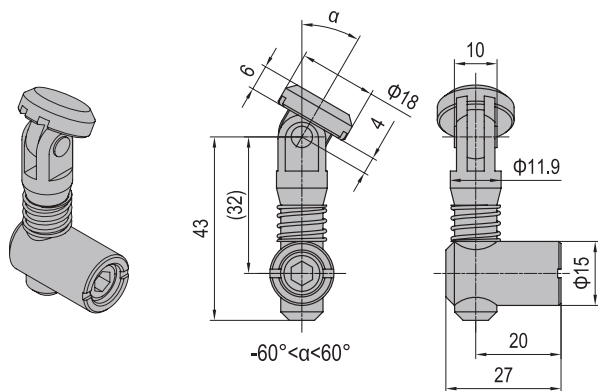

PG40-Oblique (Model C)

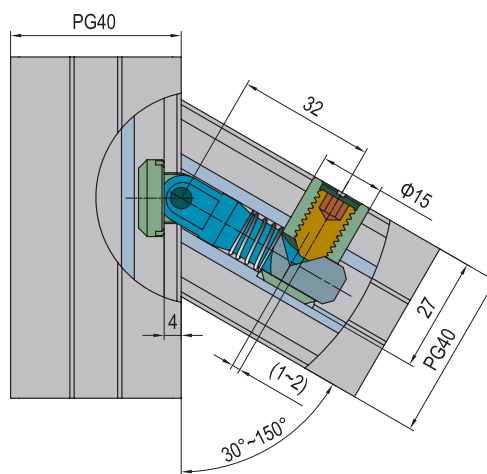
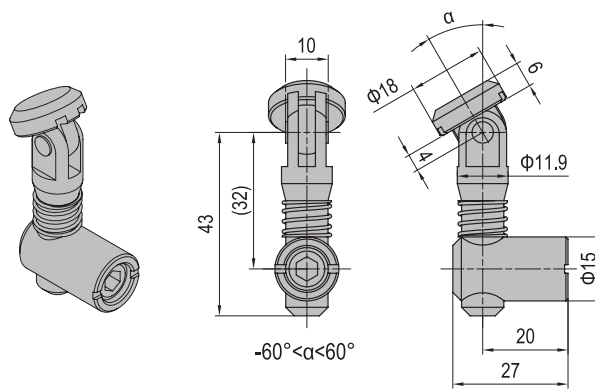

Descripción	Material	Masa (g/unit)	Part No.
Anchor Connector-PG40-Oblique (Model P)	zinc plated steel	72	3.11.40.04
Anchor Connector-PG40-Oblique (Model C)	zinc plated steel	72	3.11.40.05

Elementos de Conexión
Connecting Elements

Conector de Anclaje
Anchor Connector



PG40-Miter (Model P)

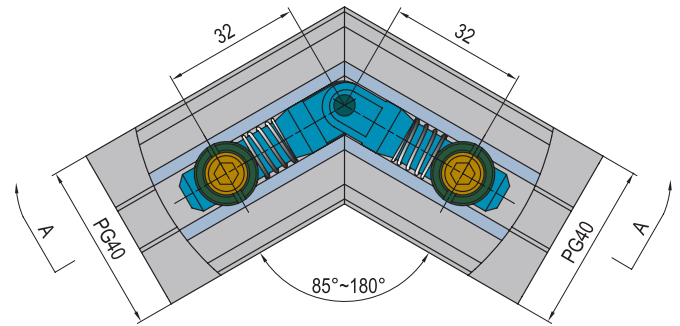
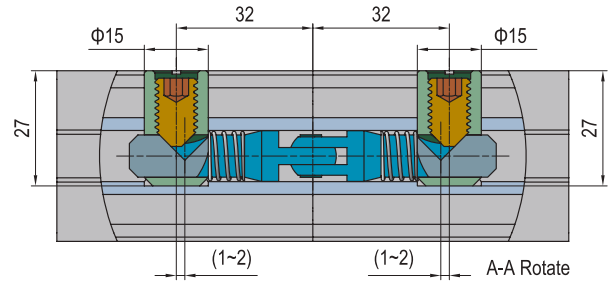
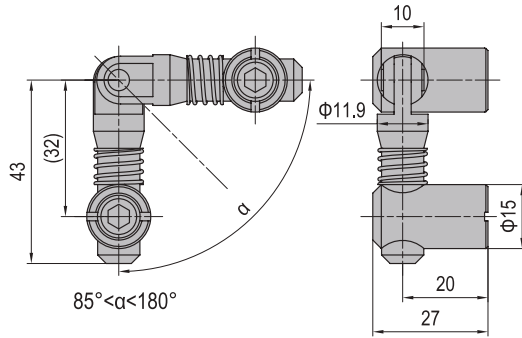
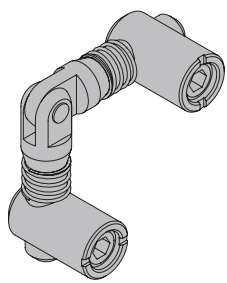

PG40-Miter (Model C)

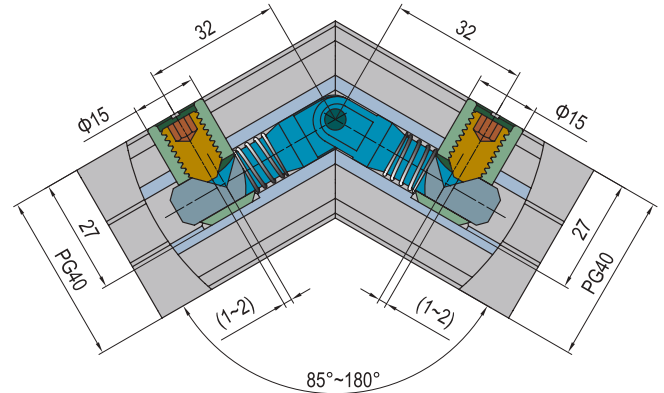
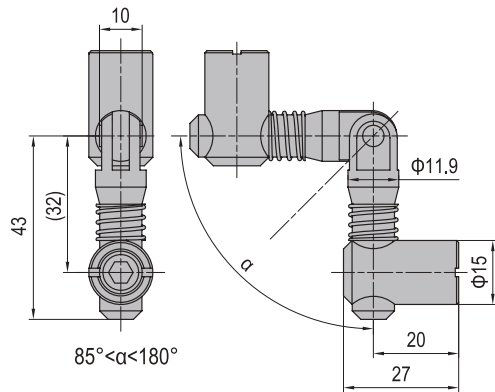
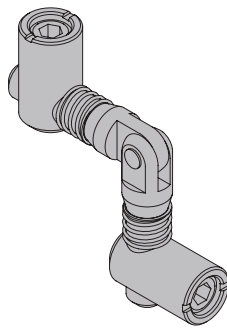

Descripción	Material	Masa (g/unit)	Part No.
Anchor Connector-PG40-Miter (Model P)	zinc plated steel	97	3.11.40.06
Anchor Connector-PG40-Miter (Model C)	zinc plated steel	97	3.11.40.07

Elementos de Conexión
Connecting Elements

Conector de Anclaje
Anchor Connector



PG45-Universal

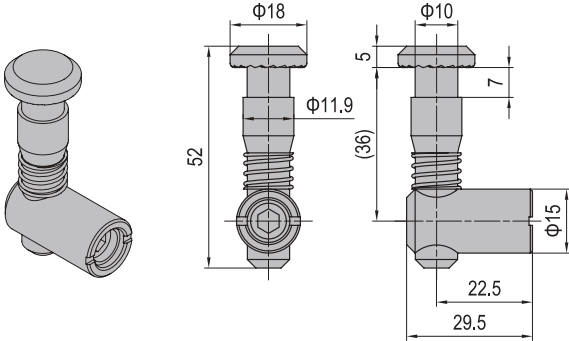

PG45-Standard (Model P)

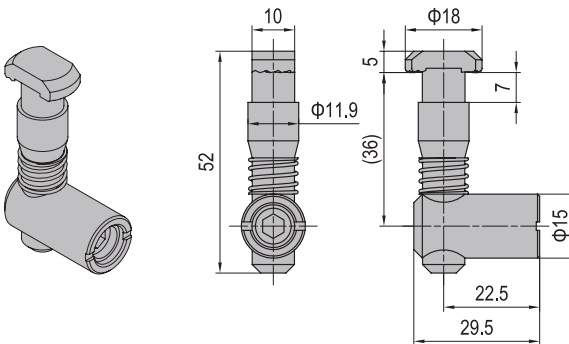

PG45-Standard (Model C)

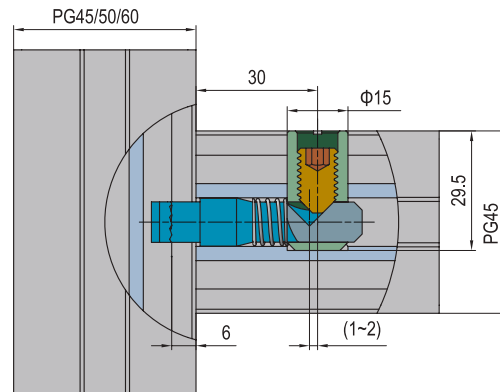
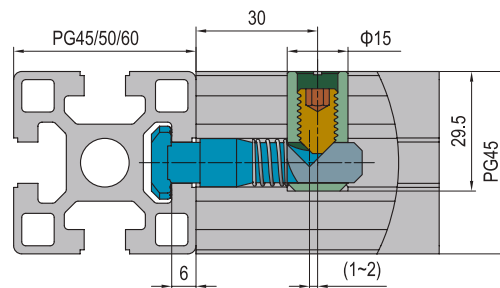
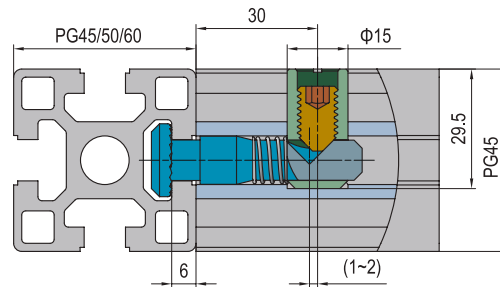
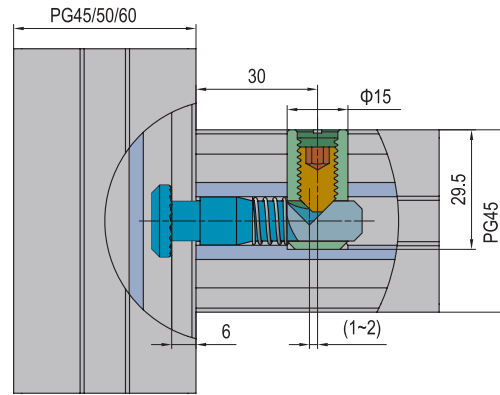
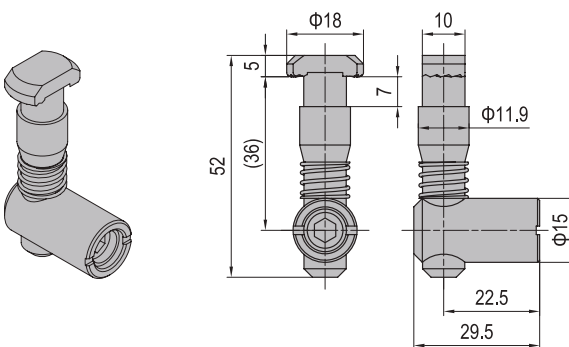

Descripción	Material	Masa (g/unit)	Part No.
Anchor Connector-PG45-Universal	zinc plated steel	64	3.11.45.01
Anchor Connector-PG45-Standard (Model P)	zinc plated steel	60	3.11.45.02
Anchor Connector-PG45-Standard (Model C)	zinc plated steel	60	3.11.45.03

Elementos de Conexión
Connecting Elements

Conector de Anclaje
Anchor Connector



PG45-Oblique (Model P)

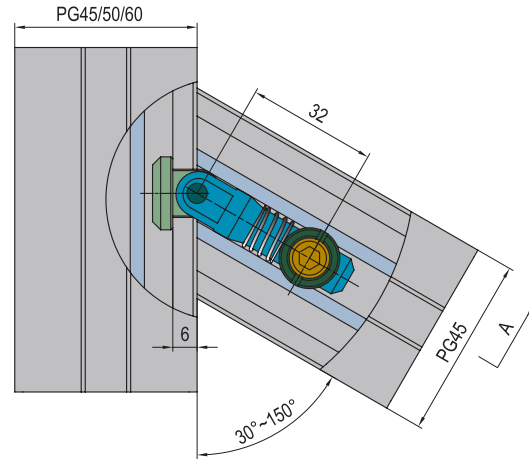
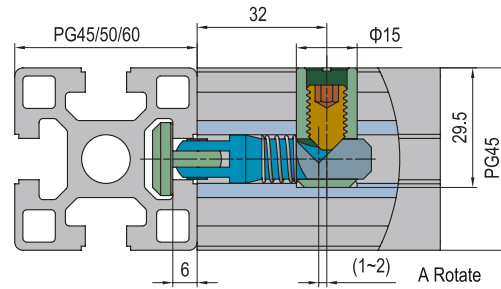
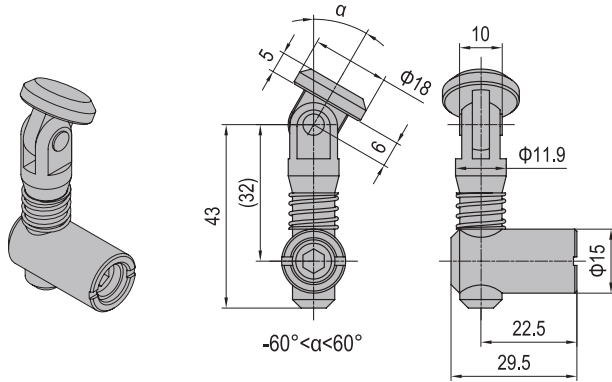

PG45-Oblique (Model C)

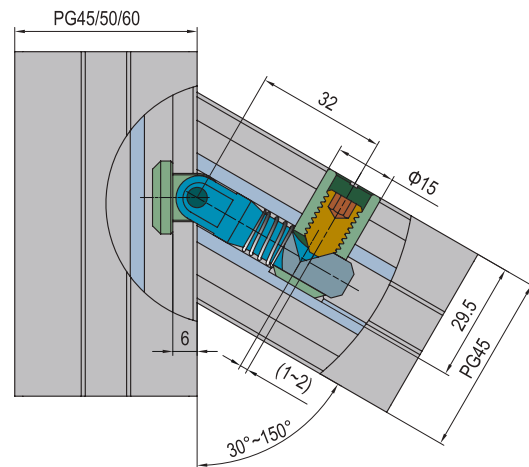
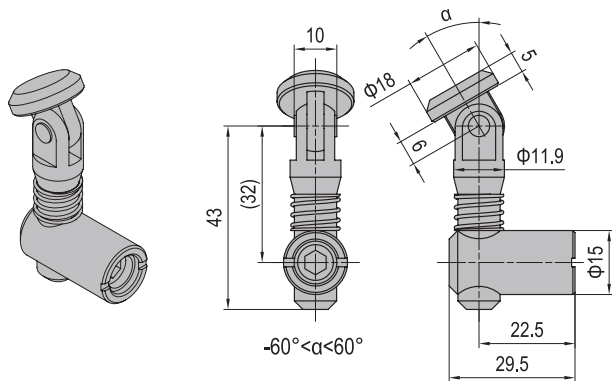

Descripción	Material	Masa (g/unit)	Part No.
Anchor Connector-PG45-Oblique (Model P)	zinc plated steel	78	3.11.45.04
Anchor Connector-PG45-Oblique (Model C)	zinc plated steel	78	3.11.45.05

Elementos de Conexión
Connecting Elements

Conector de Anclaje
Anchor Connector



PG45-Miter (Model P)

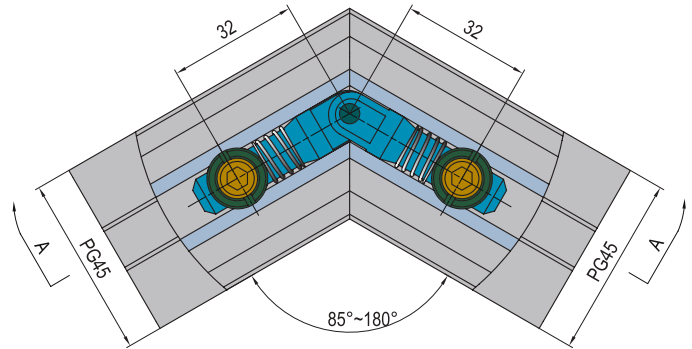
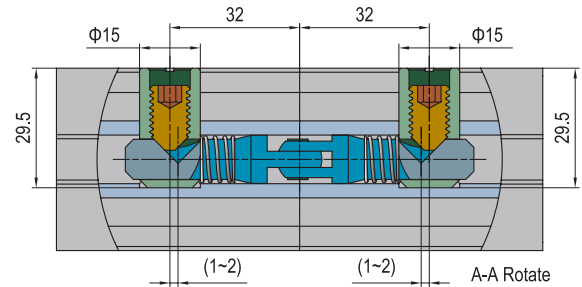
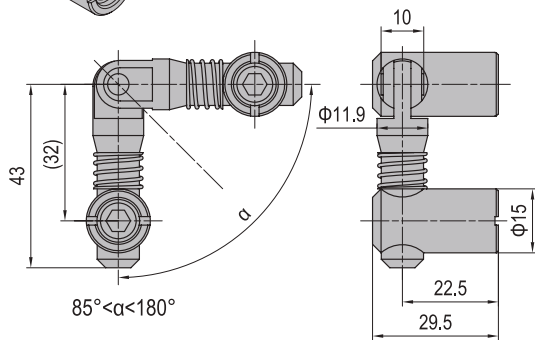
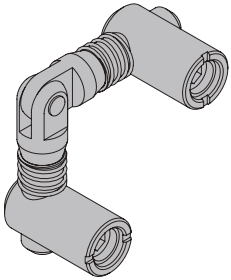

PG45-Miter (Model C)

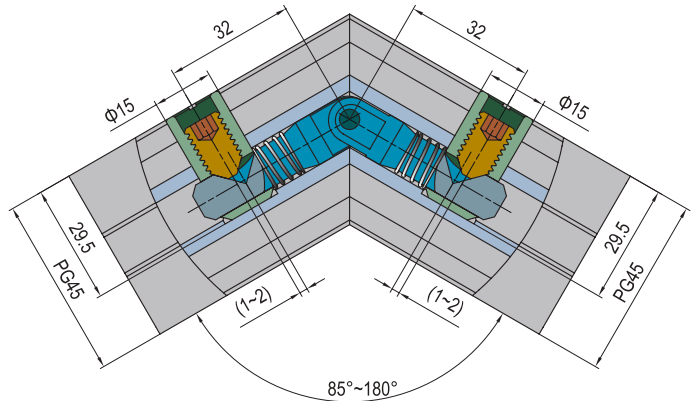
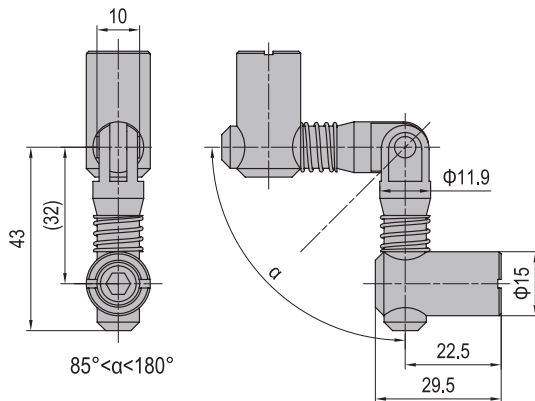
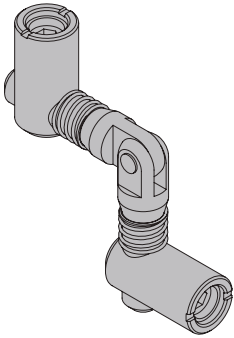

Descripción	Material	Masa (g/unit)	Part No.
Anchor Connector-PG45-Miter (Model P)	zinc plated steel	100	3.11.45.06
Anchor Connector-PG45-Miter (Model C)	zinc plated steel	100	3.11.45.07

Elementos de Conexión

Connecting Elements

Soporte de fundición PG20





Die Cast Bracket PG20

Material: Fundición de aluminio / *Die Cast Aluminium*

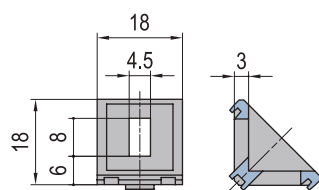

PG20-20x20



M	Fastening Set	Z	Fastening Set
	M4x6 Bolt zinc plated		M4x6 Bolt zinc plated
	M4 T Nut nickel plated		M4 Pre-set Nut nickel plated

Descripción	Fastening Set	Masa (g)	Part No.
PG20-20x20 (pcs)		5	3.21.20.2020
PG20-20x20 (set M)	2xM	12	3.21.20.2020.STM
PG20-20x20 (set Z)	2xZ	12	3.21.20.2020.STZ







Elementos de Conexión

Connecting Elements

Soporte de fundición PG30

Die Cast Bracket PG30

 Material: Fundición de aluminio / *Die Cast Aluminium*

A	Fastening Set	B	Fastening Set
	M6x14 Bolt zinc plated		M6x14 Bolt zinc plated
	M5 Washer zinc plated		M6 Washer zinc plated
	M5 T Nut nickel plated		M6 Pre-set Nut nickel plated

PG30-30x30

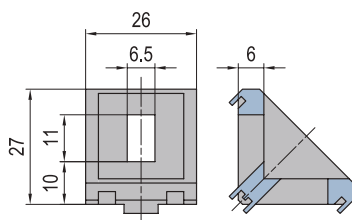

PG30-30x60

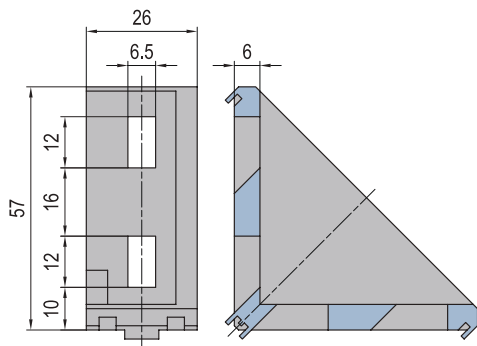

PG30-60x60

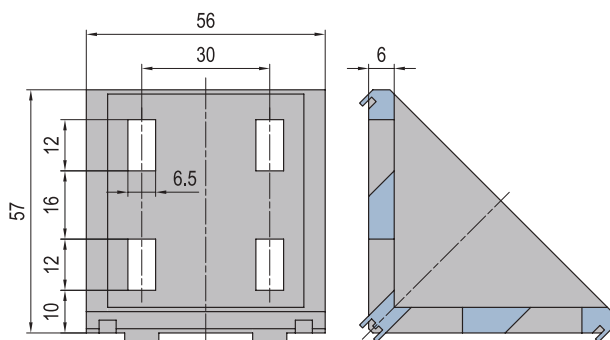

Descripción	Fastening Set	Masa (g)	Part No.
PG30-30x30 (pcs)		21	3.21.30.3030
PG30-30x30 (set A)	2xA	42	3.21.30.3030.STA
PG30-30x30 (set B)	2xB	48	3.21.30.3030.STB
PG30-30x60 (pcs)		53	3.21.30.3060
PG30-30x60 (set A)	4xA	93	3.21.30.3060.STA
PG30-30x60 (set B)	4xB	105	3.21.30.3060.STB
PG30-60x60 (pcs)		120	3.21.30.6060
PG30-60x60 (set A)	8xA	200	3.21.30.6060.STA
PG30-60x60 (set B)	8xB	224	3.21.30.6060.STB

Elementos de Conexión

Connecting Elements

Soporte de fundición PG40

Die Cast Bracket PG40

Material: Fundición de aluminio / *Die Cast Aluminium*



PG40-40x40

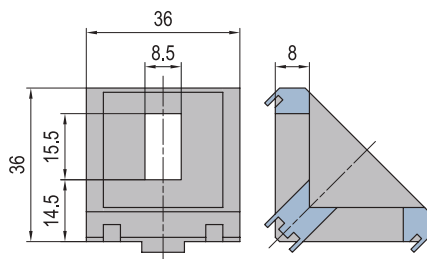

PG40-40x80

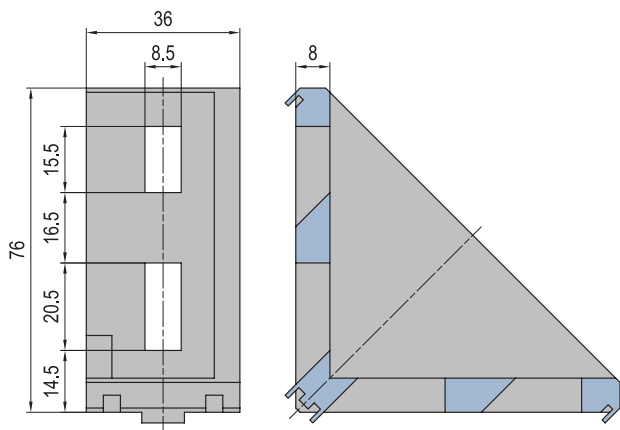

PG40-80x80

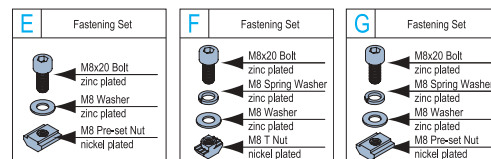
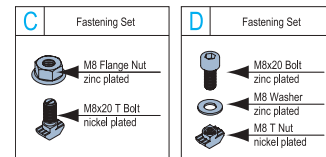
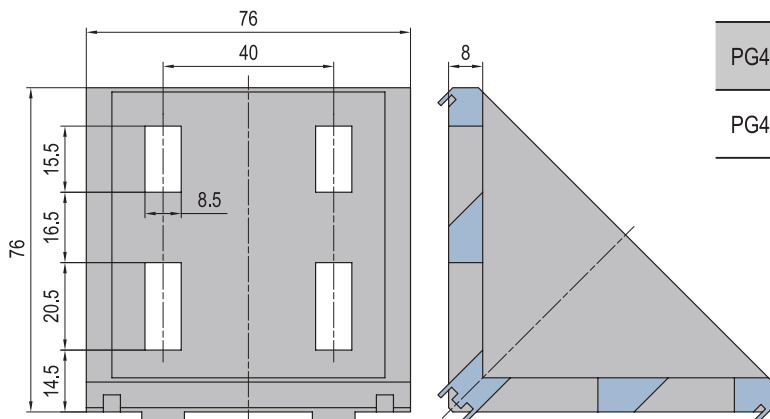

Descripción	Fastening Set	Masa (g)	Part No.
PG40-40x40 (pcs)		50	3.21.40.4040
PG40-40x40 (set C)	2xC	92	3.21.40.4040.STC
PG40-40x40 (set D)	2xD	92	3.21.40.4040.STD
PG40-40x40 (set E)	2xE	106	3.21.40.4040.STE
PG40-40x80 (pcs)		125	3.21.40.4080
PG40-40x80 (set C)	4xC	210	3.21.40.4080.STC
PG40-40x80 (set F)	4xF	220	3.21.40.4080.STF
PG40-40x80 (set G)	4xG	250	3.21.40.4080.STG
PG40-80x80 (pcs)		260	3.21.40.8080
PG40-80x80 (set C)	8xC	428	3.21.40.8080.STC
PG40-80x80 (set F)	8xF	452	3.21.40.8080.STF
PG40-80x80 (set G)	8xG	508	3.21.40.8080.STG

Elementos de Conexión

Connecting Elements

Soporte de fundición PG45

Die Cast Bracket PG45

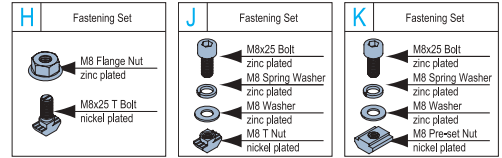
 Material: Fundición de aluminio / *Die Cast Aluminium*

PG45-45x45

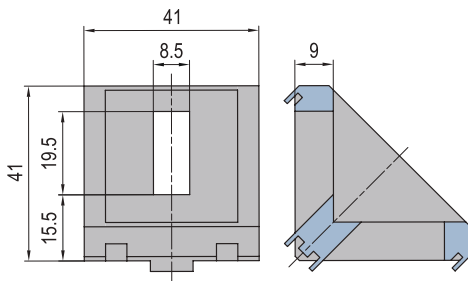

PG45-45x90

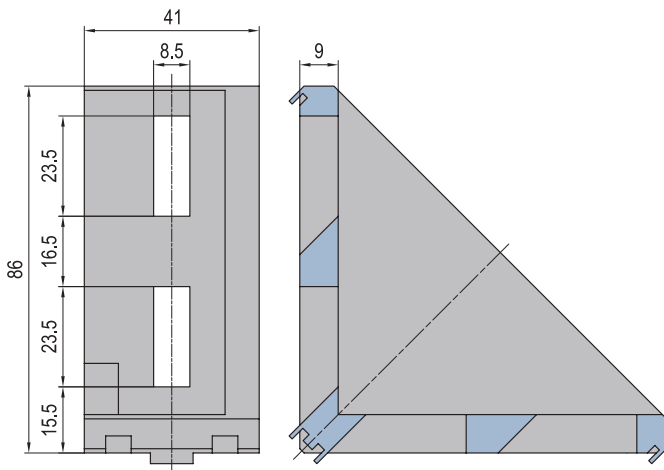

PG45-90x90

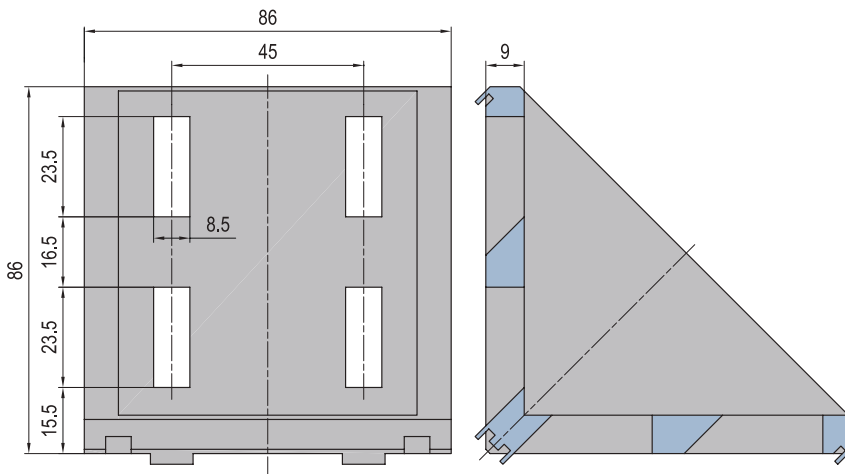

Descripción	Fastening Set	Masa (g)	Part No.
PG45-45x45 (pcs)		72	3.21.45.4545
PG45-45x45 (set H)	2xH	118	3.21.45.4545.STH
PG45-45x45 (set J)	2xJ	122	3.21.45.4545.STJ
PG45-45x45 (set K)	2xK	134	3.21.45.4545.STK
PG45-45x90 (pcs)		190	3.21.45.4590
PG45-45x90 (set H)	4xH	282	3.21.45.4590.STH
PG45-45x90 (set J)	4xJ	290	3.21.45.4590.STJ
PG45-45x90 (set K)	4xK	314	3.21.45.4590.STK
PG45-90x90 (pcs)		390	3.21.45.9090
PG45-90x90 (set H)	8xH	574	3.21.45.9090.STH
PG45-90x90 (set J)	8xJ	590	3.21.45.9090.STJ
PG45-90x90 (set K)	8xK	638	3.21.45.9090.STK

Elementos de Conexión
Connecting Elements

Tapa para soporte de fundición PG30
Bracket Cover Cap PG30

Material y color: ABS negro / *black*



PG30-30x30

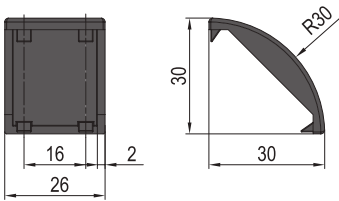

PG30-30x60

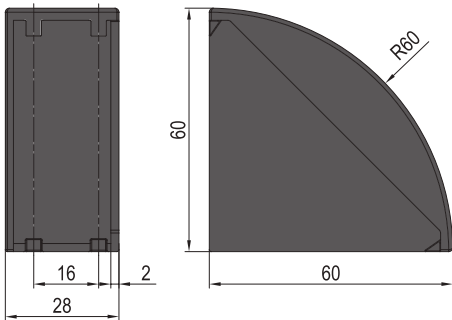

PG30-60x60

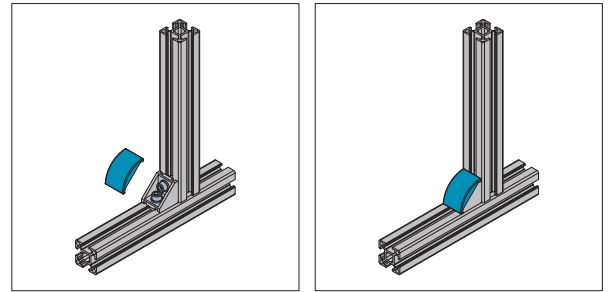
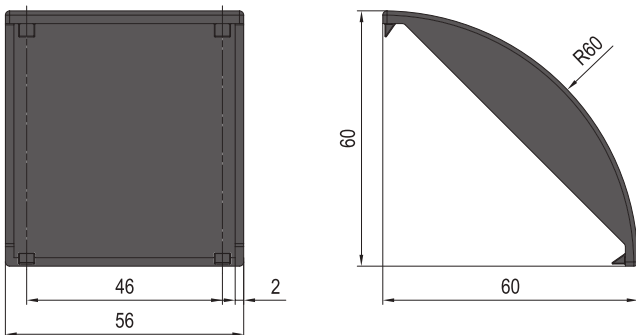

Descripción	Masa (g)	Part No.
PG30-30x30	3	3.22.30.3030
PG30-30x60	12.4	3.22.30.3060
PG30-60x60	13.9	3.22.30.6060

Elementos de Conexión

Connecting Elements

Tapa para soporte de fundición PG40

Bracket Cover Cap PG40

Material y color: ABS negro / *black*

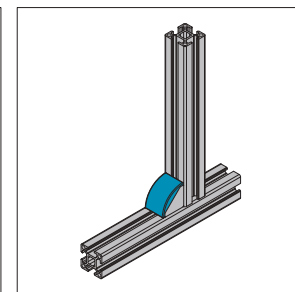
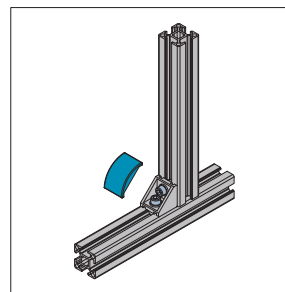

PG40-40x40

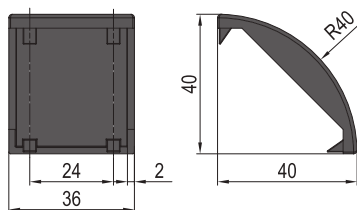

PG40-40x80

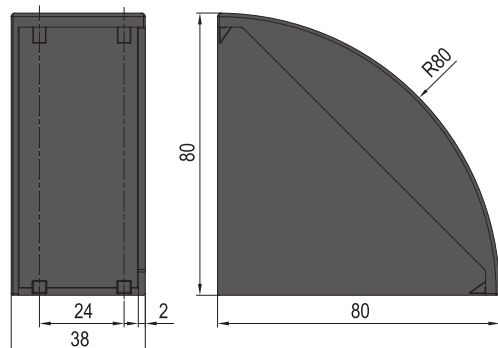

PG40-80x80

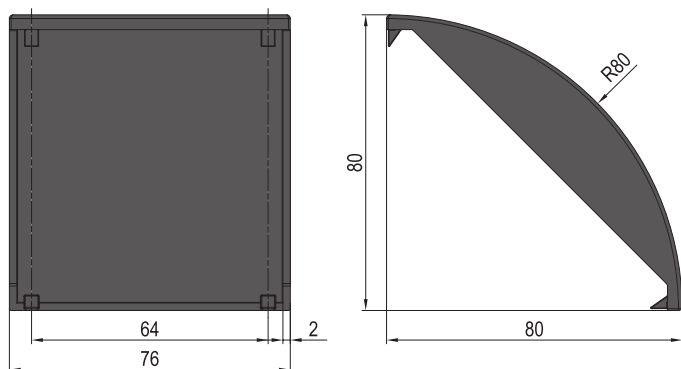

Descripción	Masa (g)	Part No.
PG40-40x40	6	3.22.40.4040
PG40-40x80	22.6	3.22.40.4080
PG40-80x80	25.6	3.22.40.8080

Elementos de Conexión

Connecting Elements

Tapa para soporte de fundición PG45
Bracket Cover Cap PG45

Material y color: ABS negro / *black*

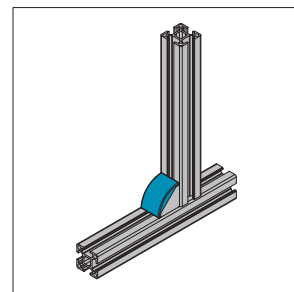
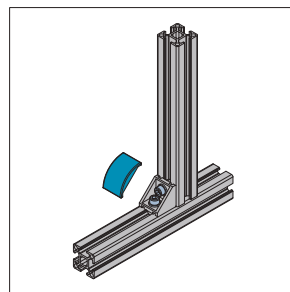

PG45-45x45

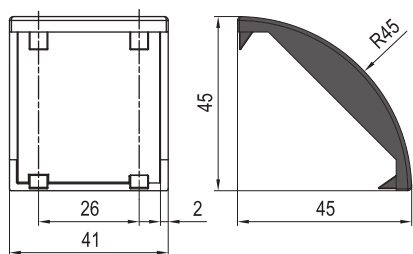

PG45-45x90

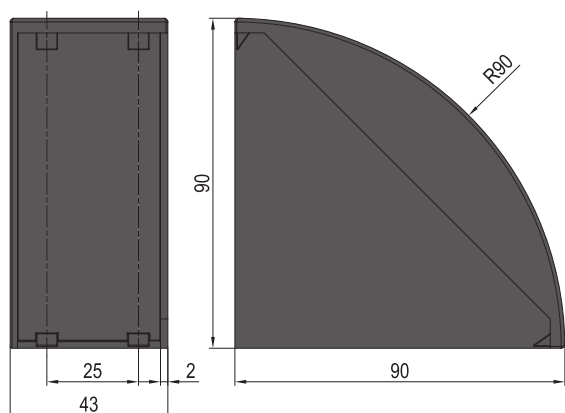

PG45-90x90

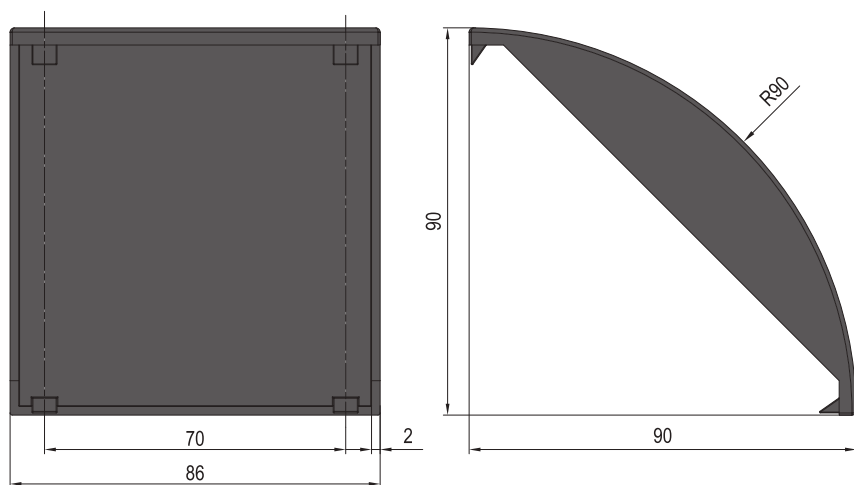

Descripción	Masa (g)	Part No.
PG45-45x45	7.6	3.22.45.4545
PG45-45x90	28.7	3.22.45.4590
PG45-90x90	32.5	3.22.45.9090



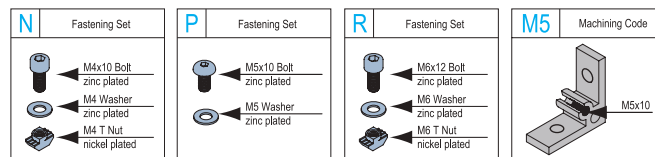

Elementos de Conexión
Connecting Elements

 Soporte de Perfil Ángulo 35x35x4
Angle Profile Bracket 35x35x4

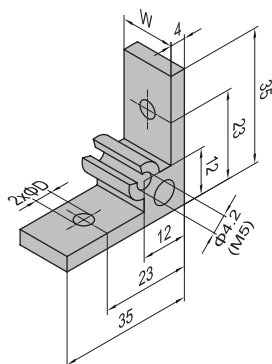
 Material: Aluminio / *Aluminium*

35x35x4



Aplicación	Descripción	D (mm)	W (mm)	Fastening Set	Machining Code	Masa (g)	Part No.
PG15 15mm 	35-15-15	4.5	10			8	3.31.35.15.15
	35-15-15	4.5	10	2xN		20	3.31.35.15.15.ST
	35-15-15	4.5	10		M5	8	3.31.35.15.15.M5
	35-15-15	4.5	10	2xN+1xP	M5	22	3.31.35.15.15.M5.ST
PG15 30mm 	35-15-30	4.5	25			21	3.31.35.15.30
	35-15-30	4.5	25	2xN		33	3.31.35.15.30.ST
	35-15-30	4.5	25		M5	21	3.31.35.15.30.M5
	35-15-30	4.5	25	2xN+1xP	M5	35	3.31.35.15.30.M5.ST
PG20 20mm 	35-20-20	4.5	14			12	3.31.35.20.20
	35-20-20	4.5	14	2xN		24	3.31.35.20.20.ST
	35-20-20	4.5	14		M5	12	3.31.35.20.20.M5
	35-20-20	4.5	14	2xN+1xP	M5	26	3.31.35.20.20.M5.ST
PG30 30mm 	35-30-30	6.5	22			19	3.31.35.30.30
	35-30-30	6.5	22	2xR		42	3.31.35.30.30.ST
	35-30-30	6.5	22		M5	19	3.31.35.30.30.M5
	35-30-30	6.5	22	2xR+1xP	M5	44	3.31.35.30.30.M5.ST



Elementos de Conexión
Connecting Elements

 Soporte de Perfil Ángulo 35x35x4
Angle Profile Bracket 35x35x4

 Material: Aluminio / *Aluminium*

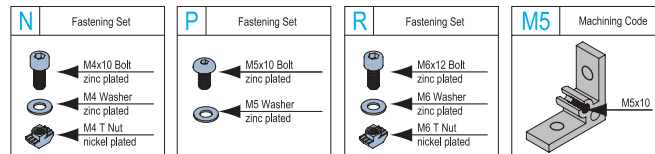
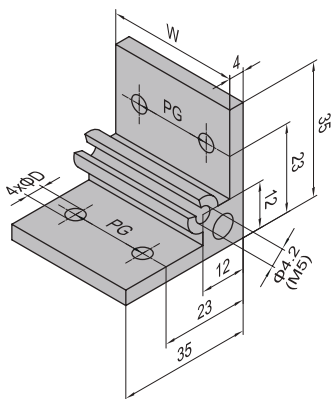
35x35x4



Aplicación	Descripción	D (mm)	W (mm)	PG (mm)	Fastening Set	Machining Code	Masa (g)	Part No.
PG20 40mm 	35-20-40	4.5	34	20			29	3.31.35.20.40
	35-20-40	4.5	34	20	4xN		50	3.31.35.20.40.ST
	35-20-40	4.5	34	20		M5	29	3.31.35.20.40.M5
	35-20-40	4.5	34	20	4xN+1xP	M5	52	3.31.35.20.40.M5.ST
PG30 60mm 	35-30-60	6.5	52	30			45	3.31.35.30.60
	35-30-60	6.5	52	30	4xR		88	3.31.35.30.60.ST
	35-30-60	6.5	52	30		M5	45	3.31.35.30.60.M5
	35-30-60	6.5	52	30	4xR+1xP	M5	90	3.31.35.30.60.M5.ST

Elementos de Conexión

Connecting Elements

Soporte de Perfil Ángulo 35x35x4
Angle Profile Bracket 35x35x4

Material: Aluminio / *Aluminium*



35x35x4

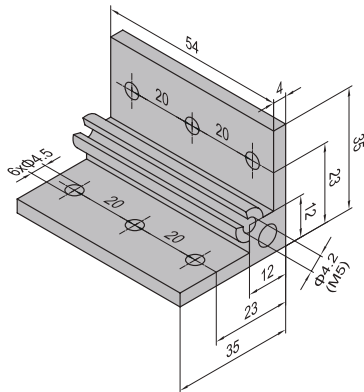

35x35x4

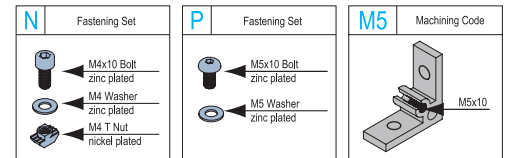
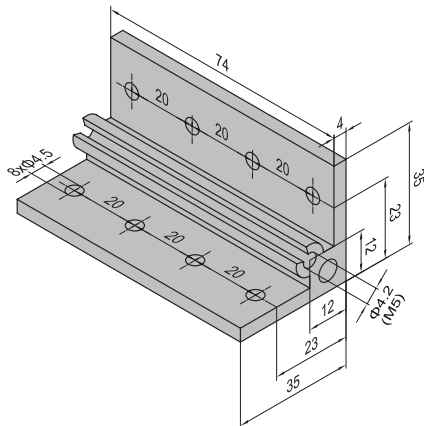







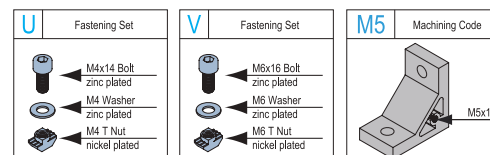
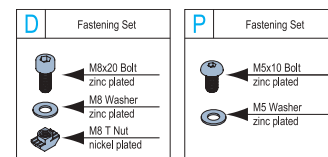
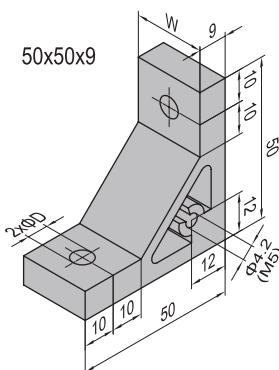

Aplicación	Descripción	Fastening Set	Machining Code	Masa (g)	Part No.
PG20 60mm 	35-20-60			47	3.31.35.20.60
	35-20-60	6xN		77	3.31.35.20.60.ST
	35-20-60		M5	47	3.31.35.20.60.M5
	35-20-60	6xN+1xP	M5	79	3.31.35.20.60.M5.ST

Aplicación	Descripción	Fastening Set	Machining Code	Masa (g)	Part No.
PG20 80mm 	35-20-80			64	3.31.35.20.80
	35-20-80	8xN		103	3.31.35.20.80.ST
	35-20-80		M5	64	3.31.35.20.80.M5
	35-20-80	8xN+1xP	M5	105	3.31.35.20.80.M5.ST

Elementos de Conexión
Connecting Elements

 Soporte de Perfil Ángulo 50x50x9
Angle Profile Bracket 50x50x9

 Material: Aluminio / *Aluminium*

Aplicación	Descripción	D (mm)	W (mm)	Fastening Set	Machining Code	Masa (g)	Part No.
PG20 20mm 	50-20-20 (pcs)	4.5	14			31	3.31.50.20.20
	50-20-20 (set)	4.5	14	2xU		43	3.31.50.20.20.ST
	50-20-20 (M5)	4.5	14		M5	31	3.31.50.20.20.M5
	50-20-20 (M5 set)	4.5	14	2xU+1xP	M5	45	3.31.50.20.20.M5.ST
PG30 30mm 	50-30-30 (pcs)	6.5	22			48	3.31.50.30.30
	50-30-30 (set)	6.5	22	2xV		71	3.31.50.30.30.ST
	50-30-30 (M5)	6.5	22		M5	48	3.31.50.30.30.M5
	50-30-30 (M5 set)	6.5	22	2xV+1xP	M5	73	3.31.50.30.30.M5.ST
PG40 40mm 	50-40-40 (pcs)	8.5	30			66	3.31.50.40.40
	50-40-40 (set)	8.5	30	2xD		112	3.31.50.40.40.ST
	50-40-40 (M5)	8.5	30		M5	66	3.31.50.40.40.M5
	50-40-40 (M5 set)	8.5	30	2xD+1xP	M5	114	3.31.50.40.40.M5.ST
PG40 60mm 	50-40-60 (pcs)	8.5	50			110	3.31.50.40.60
	50-40-60 (set)	8.5	50	2xD		156	3.31.50.40.60.ST
	50-40-60 (M5)	8.5	50		M5	110	3.31.50.40.60.M5
	50-40-60 (M5 set)	8.5	50	2xD+1xP	M5	158	3.31.50.40.60.M5.ST
PG45 45mm 	50-45-45 (pcs)	8.5	35			77	3.31.50.45.45
	50-45-45 (set)	8.5	35	2xD		123	3.31.50.45.45.ST
	50-45-45 (M5)	8.5	35		M5	77	3.31.50.45.45.M5
	50-45-45 (M5 set)	8.5	35	2xD+1xP	M5	125	3.31.50.45.45.M5.ST
PG45 60mm 	50-45-60 (pcs)	8.5	50			110	3.31.50.45.60
	50-45-60 (set)	8.5	50	2xD		156	3.31.50.45.60.ST
	50-45-60 (M5)	8.5	50		M5	110	3.31.50.45.60.M5
	50-45-60 (M5 Set)	8.5	50	2xD+1xP	M5	158	3.31.50.45.60.M5.ST
PG50 50mm 	50-50-50 (pcs)	8.5	40			88	3.31.50.50.50
	50-50-50 (set)	8.5	40	2xD		134	3.31.50.50.50.ST
	50-50-50 (M5)	8.5	40		M5	88	3.31.50.50.50.M5
	50-50-50 (M5 Set)	8.5	40	2xD+1xP	M5	136	3.31.50.50.50.M5.ST
PG60 60mm 	50-60-60 (pcs)	8.5	50			110	3.31.50.60.60
	50-60-60 (set)	8.5	50	2xD		156	3.31.50.60.60.ST
	50-60-60 (M5)	8.5	50		M5	110	3.31.50.60.60.M5
	50-60-60 (M5 Set)	8.5	50	2xD+1xP	M5	158	3.31.50.60.60.M5.ST

Elementos de Conexión
Connecting Elements

Soporte de Perfil Ángulo 50x50x9

Angle Profile Bracket 50x50x9

 Material: Aluminio / *Aluminium*

50x50x9

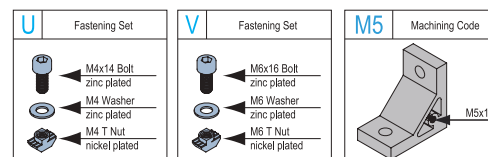
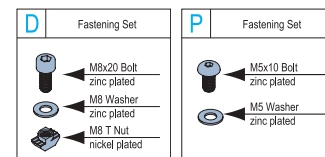
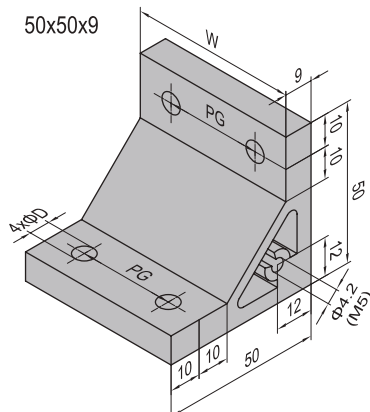

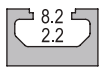
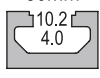
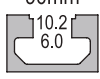
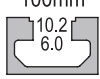
Aplicación	Descripción	D (mm)	W (mm)	PG (mm)	Fastening Set	Machining Code	Masa (g)	Part No.
PG20 40mm 	50-20-40 (pcs)	4.5	34	20			75	3.31.50.20.40
	50-20-40 (set)	4.5	34	20	4xU		95	3.31.50.20.40.ST
	50-20-40 (M5)	4.5	34	20		M5	75	3.31.50.20.40.M5
	50-20-40 (M5 set)	4.5	34	20	4xU+1xP	M5	97	3.31.50.20.40.M5.ST
PG30 60mm 	50-30-60 (pcs)	6.5	52	30			114	3.31.50.30.60
	50-30-60 (set)	6.5	52	30	4xV		156	3.31.50.30.60.ST
	50-30-60 (M5)	6.5	52	30		M5	114	3.31.50.30.60.M5
	50-30-60 (M5 set)	6.5	52	30	4xV+1xP	M5	158	3.31.50.30.60.M5.ST
PG40 80mm 	50-40-80 (pcs)	8.5	70	40			154	3.31.50.40.80
	50-40-80 (set)	8.5	70	40	4xD		240	3.31.50.40.80.ST
	50-40-80 (M5)	8.5	70	40		M5	154	3.31.50.40.80.M5
	50-40-80 (M5 set)	8.5	70	40	4xD+1xP	M5	242	3.31.50.40.80.M5.ST
PG45 90mm 	50-45-90 (pcs)	8.5	80	45			176	3.31.50.45.90
	50-45-90 (set)	8.5	80	45	4xD		262	3.31.50.45.90.ST
	50-45-90 (M5)	8.5	80	45		M5	176	3.31.50.45.90.M5
	50-45-90 (M5 set)	8.5	80	45	4xD+1xP	M5	264	3.31.50.45.90.M5.ST
PG50 100mm 	50-50-100 (pcs)	8.5	90	50			198	3.31.50.50.100
	50-50-100 (set)	8.5	90	50	4xD		284	3.31.50.50.100.ST
	50-50-100 (M5)	8.5	90	50		M5	198	3.31.50.50.100.M5
	50-50-100 (M5 set)	8.5	90	50	4xD+1xP	M5	286	3.31.50.50.100.M5.ST

Elementos de Conexión

Connecting Elements

Soporte de Perfil Ángulo 50x50x9
Angle Profile Bracket 50x50x9

Material: Aluminio / Aluminium



50x50x9

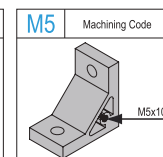
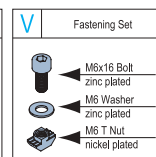
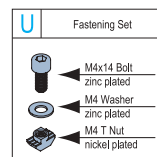
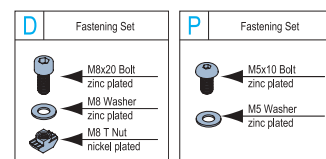
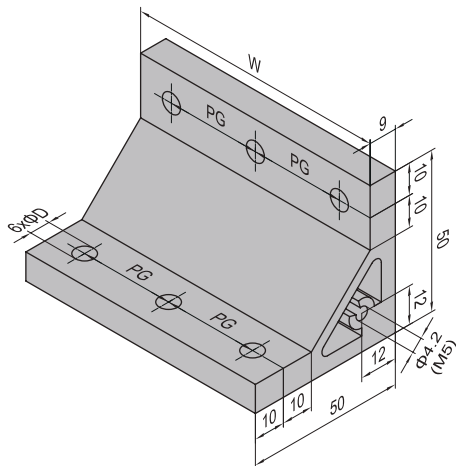

Aplicación	Descripción	D (mm)	W (mm)	PG (mm)	Fastening Set	Machining Code	Masa (g)	Part No.
PG20 60mm 	50-20-60 (pcs)	4.5	54	20			119	3.31.50.20.60
	50-20-60 (set)	4.5	54	20	6xU		147	3.31.50.20.60.ST
	50-20-60 (M5)	4.5	54	20		M5	119	3.31.50.20.60.M5
	50-20-60 (M5 set)	4.5	54	20	6xU+1xP	M5	149	3.31.50.20.60.M5.ST
PG30 90mm 	50-30-90 (pcs)	6.5	82	30			180	3.31.50.30.90
	50-30-90 (set)	6.5	82	30	6xV		241	3.31.50.30.90.ST
	50-30-90 (M5)	6.5	82	30		M5	180	3.31.50.30.90.M5
	50-30-90 (M5 set)	6.5	82	30	6xV+1xP	M5	243	3.31.50.30.90.M5.ST
PG40 120mm 	50-40-120 (pcs)	8.5	110	40			242	3.31.50.40.120
	50-40-120 (set)	8.5	110	40	6xD		372	3.31.50.40.120.ST
	50-40-120 (M5)	8.5	110	40		M5	242	3.31.50.40.120.M5
	50-40-120 (M5 set)	8.5	110	40	6xD+1xP	M5	374	3.31.50.40.120.M5.ST

Elementos de Conexión

Connecting Elements



Soporte de Perfil Ángulo 50x50x9
 Angle Profile Bracket 50x50x9

Material: Aluminio / *Aluminium*

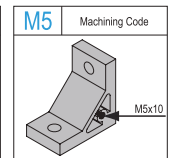
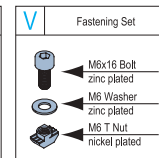
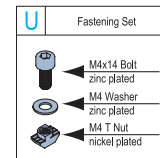
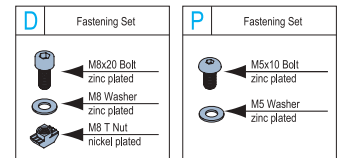
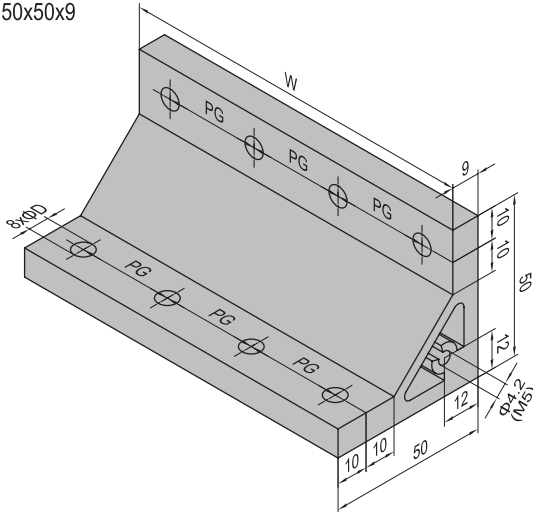

50x50x9

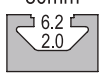
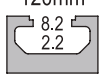
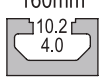

Aplicación	Descripción	D (mm)	W (mm)	PG (mm)	Fastening Set	Machining Code	Masa (g)	Part No.
PG20 80mm 	50-20-80 (pcs)	4.5	74	20			163	3.31.50.20.80
	50-20-80 (set)	4.5	74	20	8xU		199	3.31.50.20.80.ST
	50-20-80 (M5)	4.5	74	20		M5	163	3.31.50.20.80.M5
	50-20-80 (M5 set)	4.5	74	20	8xU+1xP	M5	201	3.31.50.20.80.M5.ST
PG30 120mm 	50-30-120 (pcs)	6.5	112	30			246	3.31.50.30.120
	50-30-120 (set)	6.5	112	30	8xV		326	3.31.50.30.120.ST
	50-30-120 (M5)	6.5	112	30		M5	246	3.31.50.30.120.M5
	50-30-120 (M5 set)	6.5	112	30	8xV+1xP	M5	328	3.31.50.30.120.M5.ST
PG40 160mm 	50-40-160 (pcs)	8.5	150	40			330	3.31.50.40.160
	50-40-160 (set)	8.5	150	40	8xD		502	3.31.50.40.160.ST
	50-40-160 (M5)	8.5	150	40		M5	330	3.31.50.40.160.M5
	50-40-160 (M5 set)	8.5	150	40	8xD+1xP	M5	504	3.31.50.40.160.M5.ST
PG45 180mm 	50-45-180 (pcs)	8.5	170	45			374	3.31.50.45.180
	50-45-180 (set)	8.5	170	45	8xD		546	3.31.50.45.180.ST
	50-45-180 (M5)	8.5	170	45		M5	374	3.31.50.45.180.M5
	50-45-180 (M5 set)	8.5	170	45	8xD+1xP	M5	548	3.31.50.45.180.M5.ST

Elementos de Conexión
Connecting Elements

 Soporte de Perfil Ángulo 70x70x9-135°
 Angle Profile Bracket 70x70x9-135°

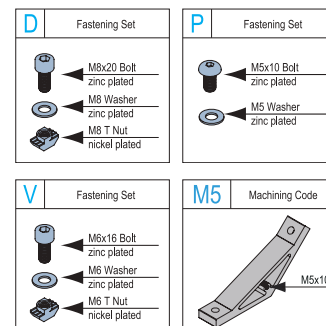
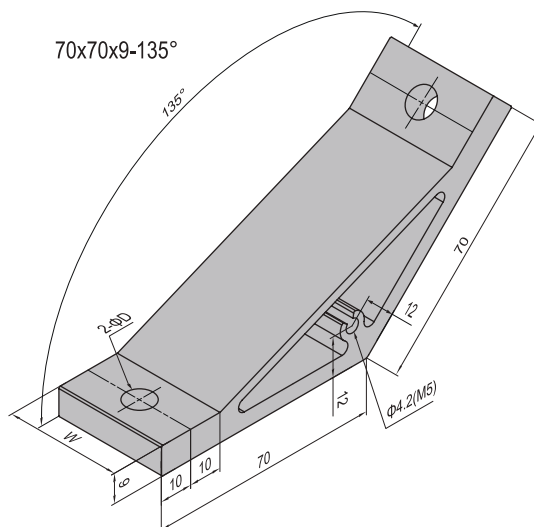
 Material: Aluminio / *Aluminium*

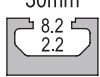
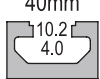
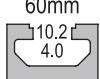
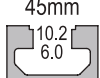
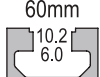
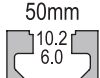
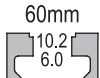
Aplicación	Descripción	D (mm)	W (mm)	Fastening Set	Machining Code	Masa (g)	Part No.
PG30 30mm 	70-30-30 (pcs)	7	22			71	3.31.70.30.30
	70-30-30 (set)	7	22	2xV		94	3.31.70.30.30.ST
	70-30-30 (M5)	7	22		M5	71	3.31.70.30.30.M5
	70-30-30 (M5 set)	7	22	2xV+1xP	M5	96	3.31.70.30.30.M5.ST
PG40 40mm 	70-40-40 (pcs)	9	30			96	3.31.70.40.40
	70-40-40 (set)	9	30	2xD		142	3.31.70.40.40.ST
	70-40-40 (M5)	9	30		M5	96	3.31.70.40.40.M5
	70-40-40 (M5 set)	9	30	2xD+1xP	M5	144	3.31.70.40.40.M5.ST
PG40 60mm 	70-40-60 (pcs)	9	50			166	3.31.70.40.60
	70-40-60 (set)	9	50	2xD		212	3.31.70.40.60.ST
	70-40-60 (M5)	9	50		M5	166	3.31.70.40.60.M5
	70-40-60 (M5 set)	9	50	2xD+1xP	M5	214	3.31.70.40.60.M5.ST
PG45 45mm 	70-45-45 (pcs)	9	35			113	3.31.70.45.45
	70-45-45 (set)	9	35	2xD		159	3.31.70.45.45.ST
	70-45-45 (M5)	9	35		M5	113	3.31.70.45.45.M5
	70-45-45 (M5 set)	9	35	2xD+1xP	M5	161	3.31.70.45.45.M5.ST
PG45 60mm 	70-45-60 (pcs)	9	50			166	3.31.70.45.60
	70-45-60 (set)	9	50	2xD		212	3.31.70.45.60.ST
	70-45-60 (M5)	9	50		M5	166	3.31.70.45.60.M5
	70-45-60 (M5 Set)	9	50	2xD+1xP	M5	214	3.31.70.45.60.M5.ST
PG50 50mm 	70-50-50 (pcs)	9	40			131	3.31.70.50.50
	70-50-50 (set)	9	40	2xD		177	3.31.70.50.50.ST
	70-50-50 (M5)	9	40		M5	131	3.31.70.50.50.M5
	70-50-50 (M5 Set)	9	40	2xD+1xP	M5	179	3.31.70.50.50.M5.ST
PG60 60mm 	70-60-60 (pcs)	9	50			166	3.31.70.60.60
	70-60-60 (set)	9	50	2xD		212	3.31.70.60.60.ST
	70-60-60 (M5)	9	50		M5	166	3.31.70.60.60.M5
	70-60-60 (M5 Set)	9	50	2xD+1xP	M5	214	3.31.70.60.60.M5.ST

Elementos de Conexión

Connecting Elements

Soporte de Perfil Ángulo 70x70x9-135°
 Angle Profile Bracket 70x70x9-135°

Material: Aluminio / *Aluminium*



70x70x9-135°

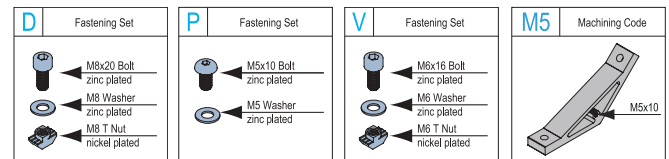
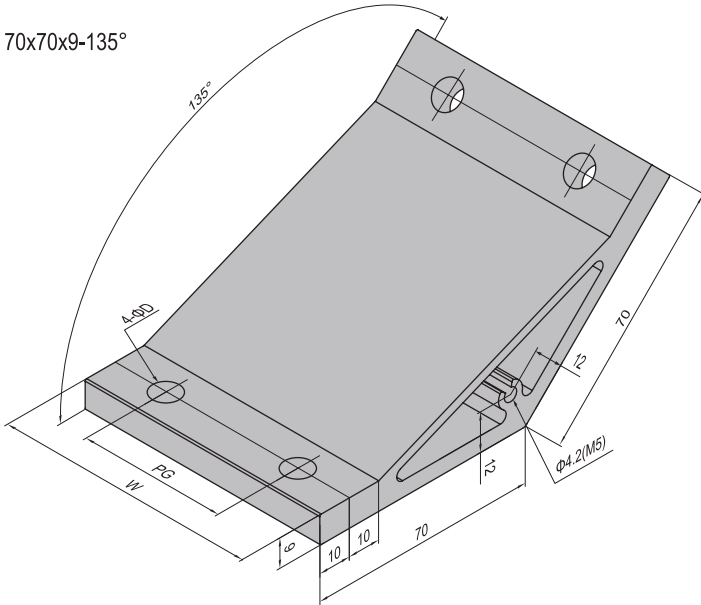

Aplicación	Descripción	D (mm)	W (mm)	PG (mm)	Fastening Set	Machining Code	Masa (g)	Part No.
PG30 60mm 	70-30-60 (pcs)	7	52	30			171	3.31.70.30.60
	70-30-60 (set)	7	52	30	4xV		213	3.31.70.30.60.ST
	70-30-60 (M5)	7	52	30		M5	171	3.31.70.30.60.M5
	70-30-60 (M5 set)	7	52	30	4xV+1xP	M5	215	3.31.70.30.60.M5.ST
PG40 80mm 	70-40-80 (pcs)	9	70	40			227	3.31.70.40.80
	70-40-80 (set)	9	70	40	4xD		313	3.31.70.40.80.ST
	70-40-80 (M5)	9	70	40		M5	227	3.31.70.40.80.M5
	70-40-80 (M5 set)	9	70	40	4xD+1xP	M5	315	3.31.70.40.80.M5.ST
PG45 90mm 	70-45-90 (pcs)	9	80	45			262	3.31.70.45.90
	70-45-90 (set)	9	80	45	4xD		348	3.31.70.45.90.ST
	70-45-90 (M5)	9	80	45		M5	262	3.31.70.45.90.M5
	70-45-90 (M5 set)	9	80	45	4xD+1xP	M5	350	3.31.70.45.90.M5.ST
PG50 100mm 	70-50-100 (pcs)	9	90	50			297	3.31.70.50.100
	70-50-100 (set)	9	90	50	4xD		383	3.31.70.50.100.ST
	70-50-100 (M5)	9	90	50		M5	297	3.31.70.50.100.M5
	70-50-100 (M5 set)	9	90	50	4xD+1xP	M5	385	3.31.70.50.100.M5.ST









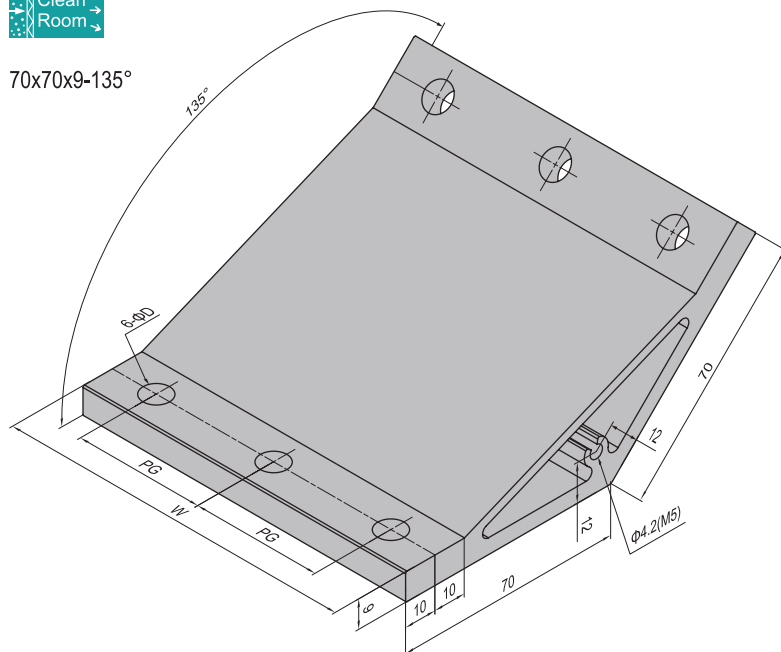

Elementos de Conexión
Connecting Elements

 Soporte de Perfil Ángulo 70x70x9-135°
 Angle Profile Bracket 70x70x9-135°

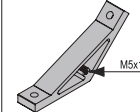
 Material: Aluminio / *Aluminium*

70x70x9-135°

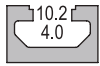

D	Fastening Set	P	Fastening Set	V	Fastening Set	M5	Machining Code
	M6x20 Bolt zinc plated		M5x10 Bolt zinc plated		M6x16 Bolt zinc plated		
	M8 Washer zinc plated		M5 Washer zinc plated		M6 Washer zinc plated		
	M8 T Nut nickel plated				M6 T Nut nickel plated		

Aplicación	Descripción	D (mm)	W (mm)	PG (mm)	Fastening Set	Machining Code	Masa (g)	Part No.
PG30 90mm 	70-30-90 (pcs)	7	82	30			270	3.31.70.30.90
	70-30-90 (set)	7	82	30	6xV		331	3.31.70.30.90.ST
	70-30-90 (M5)	7	82	30		M5	270	3.31.70.30.90.M5
	70-30-90 (M5 set)	7	82	30	6xV+1xP	M5	333	3.31.70.30.90.M5.ST
PG40 120mm 	70-40-120 (pcs)	9	110	40			357	3.31.70.40.120
	70-40-120 (set)	9	110	40	6xD		487	3.31.70.40.120.ST
	70-40-120 (M5)	9	110	40		M5	357	3.31.70.40.120.M5
	70-40-120 (M5 set)	9	110	40	6xD+1xP	M5	489	3.31.70.40.120.M5.ST

Elementos de Conexión
Connecting Elements







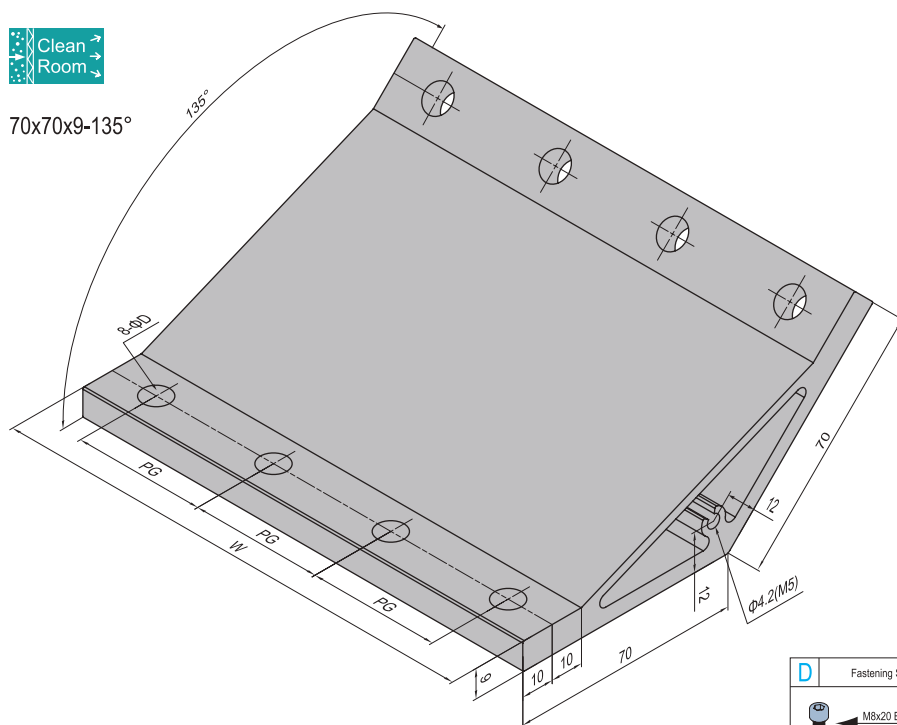

Soporte de Perfil Ángulo 70x70x9-135°

Angle Profile Bracket 70x70x9-135°

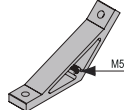
 Material: Aluminio / *Aluminium*

70x70x9-135°

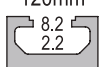
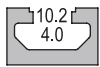
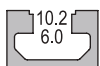

D	Fastening Set	P	Fastening Set	V	Fastening Set	M5	Machining Code
	M8x20 Bolt zinc plated		M5x10 Bolt zinc plated		M6x16 Bolt zinc plated		M5x10
	M8 Washer zinc plated		M5 Washer zinc plated		M6 Washer zinc plated		
	M8 T Nut nickel plated				M6 T Nut nickel plated		

Aplicación	Descripción	D (mm)	W (mm)	PG (mm)	Fastening Set	Machining Code	Masa (g)	Part No.
PG30 120mm 	70-30-120 (pcs)	7	112	30			369	3.31.70.30.120
	70-30-120 (set)	7	112	30	8xD		449	3.31.70.30.120.ST
	70-30-120 (M5)	7	112	30		M5	369	3.31.70.30.120.M5
	70-30-120 (M5 set)	7	112	30	8xV+1xP	M5	451	3.31.70.30.120.M5.ST
PG40 160mm 	70-40-160 (pcs)	9	150	40			488	3.31.70.40.160
	70-40-160 (set)	9	150	40	8xD		660	3.31.70.40.160.ST
	70-40-160 (M5)	9	150	40		M5	488	3.31.70.40.160.M5
	70-40-160 (M5 set)	9	150	40	8xD+1xP	M5	662	3.31.70.40.160.M5.ST
PG45 180mm 	70-45-180 (pcs)	9	170	45			558	3.31.70.45.180
	70-45-180 (set)	9	170	45	8xD		730	3.31.70.45.180.ST
	70-45-180 (M5)	9	170	45		M5	558	3.31.70.45.180.M5
	70-45-180 (M5 set)	9	170	45	8xD+1xP	M5	732	3.31.70.45.180.M5.ST



Elementos de Conexión
Connecting Elements

 Soporte de Perfil Ángulo 80x80x9-45°
 Angle Profile Bracket 80x80x9-45°

 Material: Aluminio / *Aluminium*

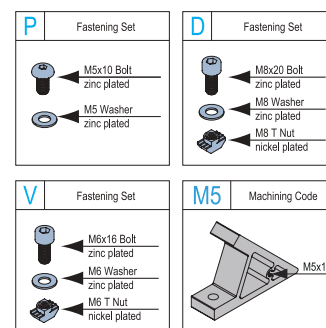
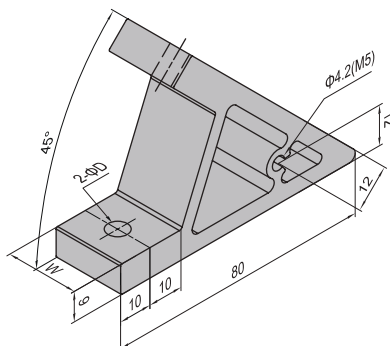
80x80x9-45°

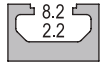
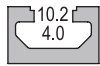
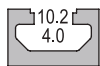
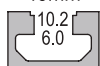
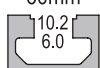
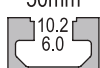

Aplicación	Descripción	D (mm)	W (mm)	Fastening Set	Machining Code	Masa (g)	Part No.
PG30 30mm 	80-30-30 (pcs)	7	22			68	3.31.80.30.30
	80-30-30 (set)	7	22	2xV		91	3.31.80.30.30.ST
	80-30-30 (M5)	7	22		M5	68	3.31.80.30.30.M5
	80-30-30 (M5 set)	7	22	2xV+1xP	M5	93	3.31.80.30.30.M5.ST
PG40 40mm 	80-40-40 (pcs)	9	30			89	3.31.80.40.40
	80-40-40 (set)	9	30	2xD		135	3.31.80.40.40.ST
	80-40-40 (M5)	9	30		M5	89	3.31.80.40.40.M5
	80-40-40 (M5 set)	9	30	2xD+1xP	M5	137	3.31.80.40.40.M5.ST
PG40 60mm 	80-40-60 (pcs)	9	50			151	3.31.80.40.60
	80-40-60 (set)	9	50	2xD		197	3.31.80.40.60.ST
	80-40-60 (M5)	9	50		M5	151	3.31.80.40.60.M5
	80-40-60 (M5 set)	9	50	2xD+1xP	M5	199	3.31.80.40.60.M5.ST
PG45 45mm 	80-45-45 (pcs)	9	35			105	3.31.80.45.45
	80-45-45 (set)	9	35	2xD		151	3.31.80.45.45.ST
	80-45-45 (M5)	9	35		M5	105	3.31.80.45.45.M5
	80-45-45 (M5 set)	9	35	2xD+1xP	M5	153	3.31.80.45.45.M5.ST
PG45 60mm 	80-45-60 (pcs)	9	50			151	3.31.80.45.60
	80-45-60 (set)	9	50	2xD		197	3.31.80.45.60.ST
	80-45-60 (M5)	9	50		M5	151	3.31.80.45.60.M5
	80-45-60 (M5 set)	9	50	2xD+1xP	M5	199	3.31.80.45.60.M5.ST
PG50 50mm 	80-50-50 (pcs)	9	50			120	3.31.80.50.50
	80-50-50 (set)	9	50	2xD		166	3.31.80.50.50.ST
	80-50-50 (M5)	9	50		M5	120	3.31.80.50.50.M5
	80-50-50 (M5 Set)	9	50	2xD+1xP	M5	168	3.31.80.50.50.M5.ST
PG60 60mm 	80-60-60 (pcs)	9	50			151	3.31.80.60.60
	80-60-60 (set)	9	50	2xD		197	3.31.80.60.60.ST
	80-60-60 (M5)	9	50		M5	151	3.31.80.60.60.M5
	80-60-60 (M5 Set)	9	50	2xD+1xP	M5	199	3.31.80.60.60.M5.ST

Elementos de Conexión
Connecting Elements







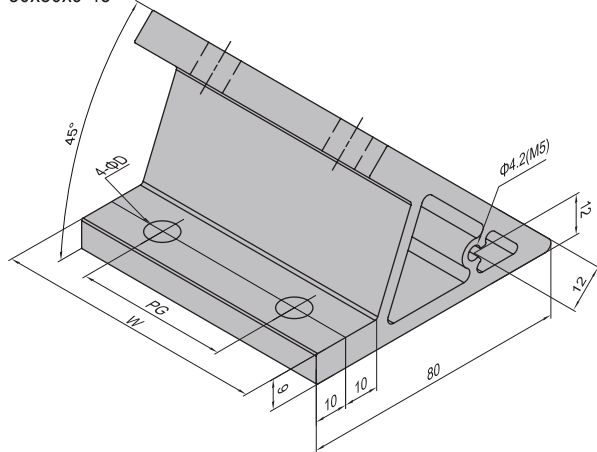

Soporte de Perfil Ángulo 80x80x9-45°

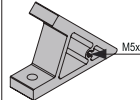

Angle Profile Bracket 80x80x9-45°

 Material: Aluminio / *Aluminium*

80x80x9-45°

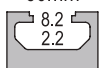
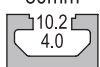
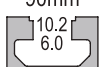

D	Fastening Set	P	Fastening Set	V	Fastening Set	M5	Machining Code
	M8x20 Bolt zinc plated		M5x10 Bolt zinc plated		M6x16 Bolt zinc plated		M5x10
	M8 Washer zinc plated		M5 Washer zinc plated		M6 Washer zinc plated		
	M8 T Nut nickel plated				M6 T Nut nickel plated		

Aplicación	Descripción	D (mm)	W (mm)	PG (mm)	Fastening Set	Machining Code	Masa (g)	Part No.
PG30 60mm 	80-30-60 (pcs)	7	52	30			156	3.31.80.30.60
	80-30-60 (set)	7	52	30	4xV		198	3.31.80.30.60.ST
	80-30-60 (M5)	7	52	30		M5	156	3.31.80.30.60.M5
	80-30-60 (M5 set)	7	52	30	4xV+1xP	M5	200	3.31.80.30.60.M5.ST
PG40 80mm 	80-40-80 (pcs)	9	70	40			209	3.31.80.40.80
	80-40-80 (set)	9	70	40	4xD		295	3.31.80.40.80.ST
	80-40-80 (M5)	9	70	40		M5	209	3.31.80.40.80.M5
	80-40-80 (M5 set)	9	70	40	4xD+1xP	M5	297	3.31.80.40.80.M5.ST
PG45 90mm 	80-45-90 (pcs)	9	80	45			240	3.31.80.45.90
	80-45-90 (set)	9	80	45	4xD		326	3.31.80.45.90.ST
	80-45-90 (M5)	9	80	45		M5	240	3.31.80.45.90.M5
	80-45-90 (M5 set)	9	80	45	4xD+1xP	M5	328	3.31.80.45.90.M5.ST
PG50 100mm 	80-50-100 (pcs)	9	90	50			271	3.31.80.50.100
	80-50-100 (set)	9	90	50	4xD		357	3.31.80.50.100.ST
	80-50-100 (M5)	9	90	50		M5	271	3.31.80.50.100.M5
	80-50-100 (M5 set)	9	90	50	4xD+1xP	M5	359	3.31.80.50.100.M5.ST

Elementos de Conexión

Connecting Elements

Soporte de Perfil Ángulo 80x80x9-45°

Angle Profile Bracket 80x80x9-45°

Material: Aluminio / *Aluminium*



80x80x9-45°

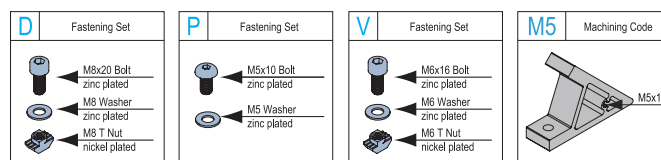
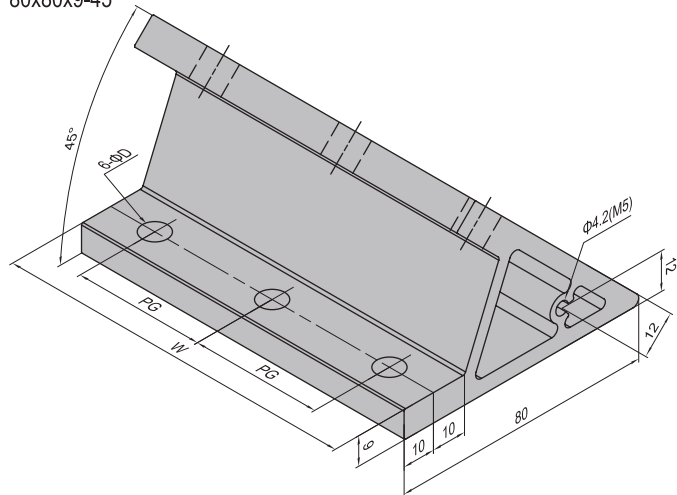

Aplicación	Descripción	D (mm)	W (mm)	PG (mm)	Fastening Set	Machining Code	Masa (g)	Part No.
PG30 90mm 	80-30-90 (pcs)	7	82	30			247	3.31.80.30.90
	80-30-90 (set)	7	82	30	6xV		308	3.31.80.30.90.ST
	80-30-90 (M5)	7	82	30		M5	247	3.31.80.30.90.M5
	80-30-90 (M5 set)	7	82	30	6xV+1xP	M5	310	3.31.80.30.90.M5.ST
PG40 120mm 	80-40-120 (pcs)	9	110	40			329	3.31.80.40.120
	80-40-120 (set)	9	110	40	6xD		459	3.31.80.40.120.ST
	80-40-120 (M5)	9	110	40		M5	329	3.31.80.40.120.M5
	80-40-120 (M5 set)	9	110	40	6xD+1xP	M5	461	3.31.80.40.120.M5.ST







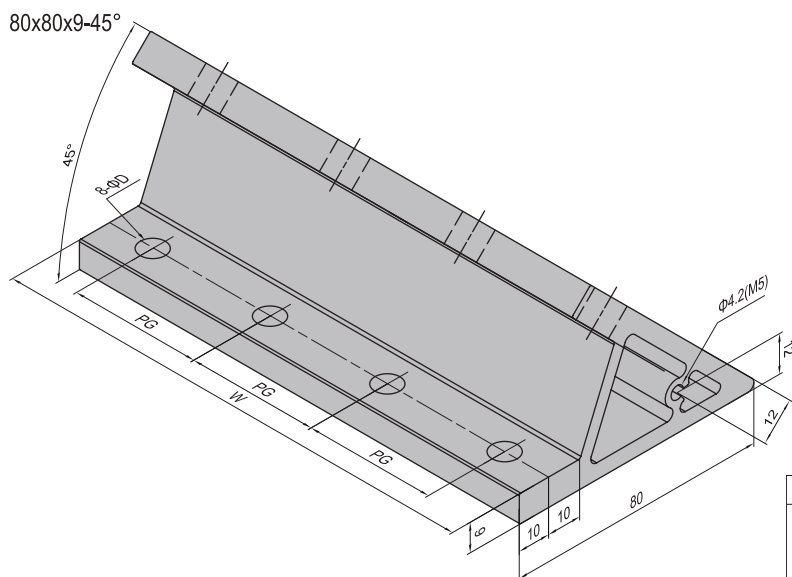

Elementos de Conexión

Connecting Elements

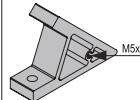
Soporte de Perfil Ángulo 80x80x9-45°

Angle Profile Bracket 80x80x9-45°

 Material: Aluminio / *Aluminium*

D	Fastening Set	P	Fastening Set	V	Fastening Set	M5	Machining Code
	M8x20 Bolt zinc plated		M5x10 Bolt zinc plated		M6x16 Bolt zinc plated		M5x10
	M8 Washer zinc plated		M5 Washer zinc plated		M6 Washer zinc plated		
	M8 T Nut nickel plated				M6 T Nut nickel plated		

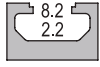
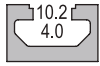
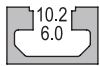
Aplicación	Descripción	D (mm)	W (mm)	PG (mm)	Fastening Set	Machining Code	Masa (g)	Part No.
PG30 120mm 	80-30-120 (pcs)	7	112	30			337	3.31.80.30.120
	80-30-120 (set)	7	112	30	8xV		417	3.31.80.30.120.ST
	80-30-120 (M5)	7	112	30		M5	337	3.31.80.30.120.M5
	80-30-120 (M5 set)	7	112	30	8xV+1xP	M5	419	3.31.80.30.120.M5.ST
PG40 160mm 	80-40-160 (pcs)	9	150	40			449	3.31.80.40.160
	80-40-160 (set)	9	150	40	8xD		621	3.31.80.40.160.ST
	80-40-160 (M5)	9	150	40		M5	449	3.31.80.40.160.M5
	80-40-160 (M5 set)	9	150	40	8xD+1xP	M5	623	3.31.80.40.160.M5.ST
PG45 180mm 	80-45-180 (pcs)	9	170	45			510	3.31.80.45.180
	80-45-180 (set)	9	170	45	8xD		682	3.31.80.45.180.ST
	80-45-180 (M5)	9	170	45		M5	510	3.31.80.45.180.M5
	80-45-180 (M5 set)	9	170	45	8xD+1xP	M5	684	3.31.80.45.180.M5.ST

Elementos de Conexión
Connecting Elements









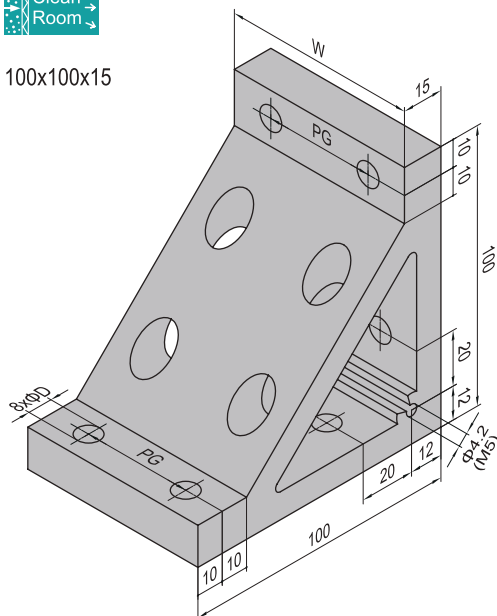

Soporte de Perfil Ángulo 100x100x15

Angle Profile Bracket 100x100x15

 Material: Aluminio / *Aluminium*

100x100x15

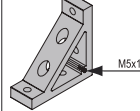

P Fastening Set	W Fastening Set	J Fastening Set	M5 Machining Code
 M5x10 Bolt zinc plated  M5 Washer zinc plated	 M8x30 Bolt zinc plated  M8 Spring Washer zinc plated  M8 Washer zinc plated  M8 T Nut nickel plated	 M8x25 Bolt zinc plated  M8 Spring Washer zinc plated  M8 Washer zinc plated  M8 T Nut nickel plated	 M5x10

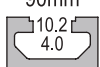
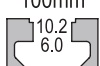
Aplicación	Descripción	D (mm)	W (mm)	PG (mm)	Fastening Set	Machining Code	Masa (g)	Part No.
PG40 80mm 	100-40-80 (pcs)	9	70	40			522	3.31.100.40.80
	100-40-80 (set)	9	70	40	4xW+4xJ		730	3.31.100.40.80.ST
	100-40-80 (M5)	9	70	40		M5	522	3.31.100.40.80.M5
	100-40-80 (M5 set)	9	70	40	4xW+4xJ+1xP	M5	732	3.31.100.40.80.M5.ST
PG45 90mm 	100-45-90 (pcs)	9	80	45			605	3.31.100.45.90
	100-45-90 (set)	9	80	45	4xW+4xJ		813	3.31.100.45.90.ST
	100-45-90 (M5)	9	80	45		M5	605	3.31.100.45.90.M5
	100-45-90 (M5 set)	9	80	45	4xW+4xJ+1xP	M5	815	3.31.100.45.90.M5.ST
PG50 100mm 	100-50-100 (pcs)	9	90	50			688	3.31.100.50.100
	100-50-100 (set)	9	90	50	4xW+4xJ		896	3.31.100.50.100.ST
	100-50-100 (M5)	9	90	50		M5	688	3.31.100.50.100.M5
	100-50-100 (M5 set)	9	90	50	4xW+4xJ+1xP	M5	898	3.31.100.50.100.M5.ST

Elementos de Conexión
Connecting Elements

Soporte de Perfil Ángulo 100x100x15
Angle Profile Bracket 100x100x15

Material: Aluminio / *Aluminium*



100x100x15

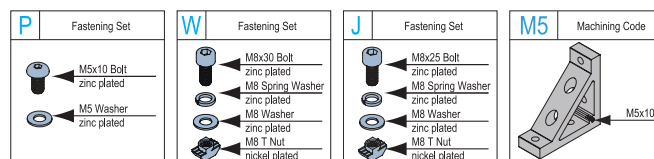
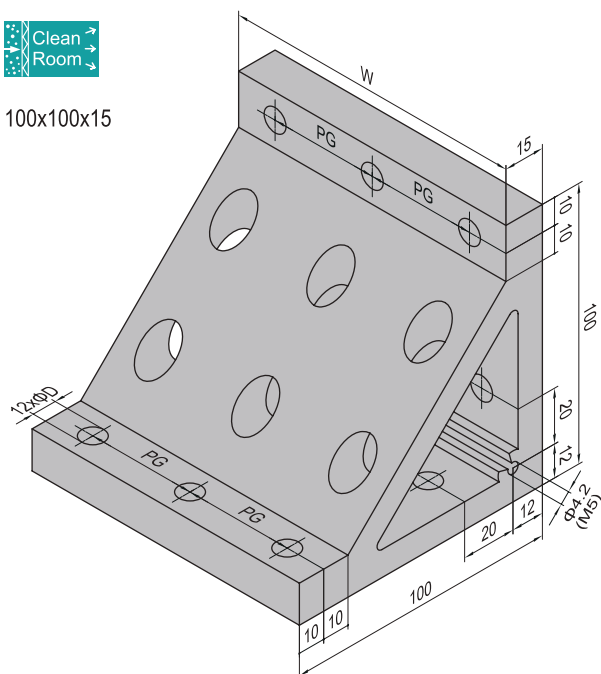

Aplicación	Descripción	D (mm)	W (mm)	PG (mm)	Fastening Set	Machining Code	Masa (g)	Part No.
PG40 120mm 	100-40-120 (pcs)	9	110	40			824	3.31.100.40.120
	100-40-120 (set)	9	110	40	6xW+6xJ		1136	3.31.100.40.120.ST
	100-40-120 (M5)	9	110	40		M5	824	3.31.100.40.120.M5
	100-40-120 (M5 set)	9	110	40	6xW+6xJ+1xP	M5	1138	3.31.100.40.120.M5.ST



Elementos de Conexión
Connecting Elements

 Soporte de Perfil Ángulo 100x100x15
Angle Profile Bracket 100x100x15

 Material: Aluminio / *Aluminium*

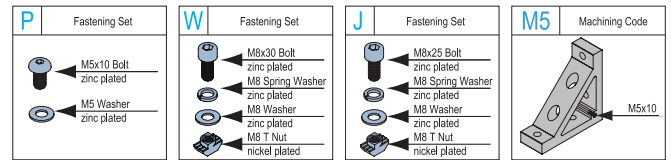
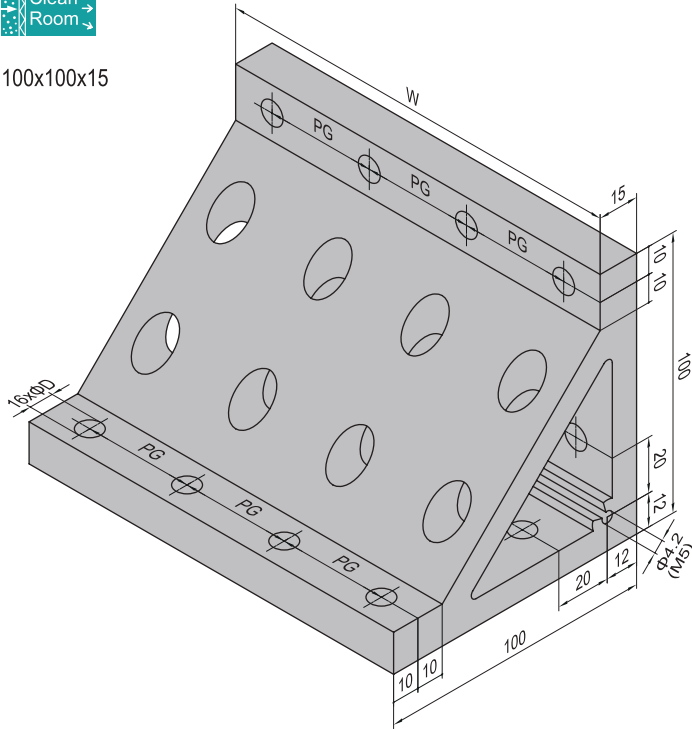
100x100x15



Aplicación	Descripción	D (mm)	W (mm)	PG (mm)	Fastening Set	Machining Code	Masa (g)	Part No.
PG40 160mm 	100-40-160 (pcs)	9	150	40			1127	3.31.100.40.160
	100-40-160 (set)	9	150	40	8xW+8xJ		1543	3.31.100.40.160.ST
	100-40-160 (M5)	9	150	40		M5	1127	3.31.100.40.160.M5
	100-40-160 (M5 set)	9	150	40	8xW+8xJ+1xP	M5	1545	3.31.100.40.160.M5.ST
PG45 180mm 	100-45-180 (pcs)	9	170	45			1293	3.31.100.45.180
	100-45-180 (set)	9	170	45	8xW+8xJ		1709	3.31.100.45.180.ST
	100-45-180 (M5)	9	170	45		M5	1293	3.31.100.45.180.M5
	100-45-180 (M5 set)	9	170	45	8xW+8xJ+1xP	M5	1711	3.31.100.45.180.M5.ST

Elementos de Conexión
Connecting Elements

Soporte Interior (roscado)
Inner Bracket (with top thread)

Los Soportes Interiores son usados comunmente en la construcción de marcos de paneles, y cerramientos de seguridad debido a que el elemento de conexión queda escondido dentro de la ranura del perfil.
Inner brackets are frequently used for panel frames, and protection frames as the bracket is hidden inside the T Slot.

Material: Fundición de zinc / *Die Cast Zinc*

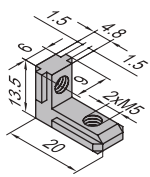

- M5x6
- Inner Bracket 3.41.06A
- Inner Bracket 3.41.06B

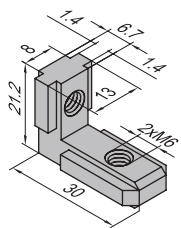

- M6x8
- Inner Bracket 3.41.08A
- Inner Bracket 3.41.08B

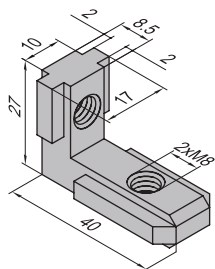

- M8x10
- Inner Bracket 3.41.10A
- Inner Bracket 3.41.10B

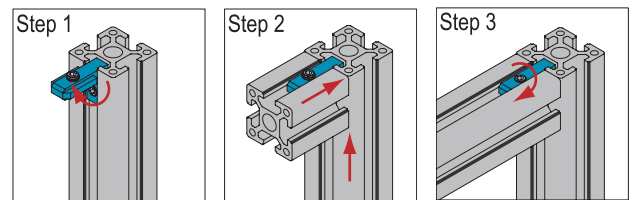
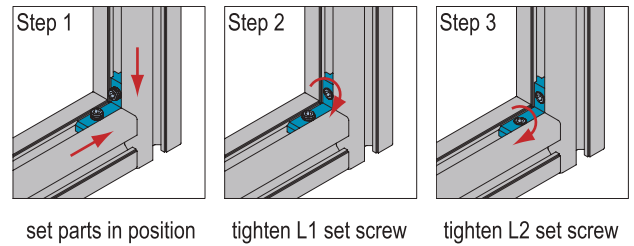
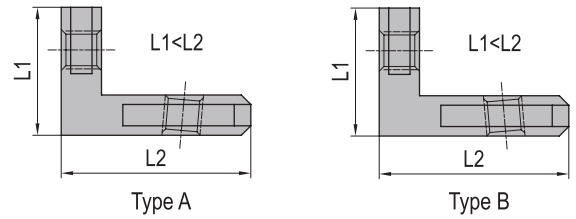
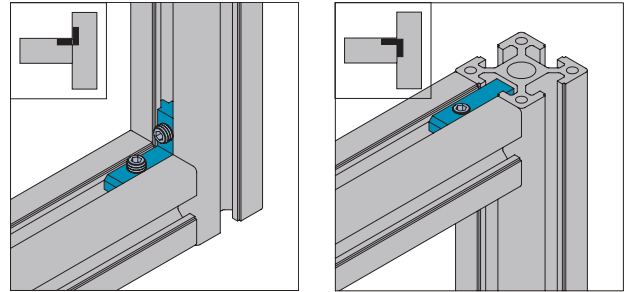

Descripción	Masa (g/pcs)	Part No.
Inner Bracket-6-A (with top thread)	6	3.41.06A
Inner Bracket-6-B (with top thread)	6	3.41.06B
Inner Bracket-8-A (with top thread)	18	3.41.08A
Inner Bracket-8-B (with top thread)	18	3.41.08B
Inner Bracket-10-A (with top thread)	36	3.41.10A
Inner Bracket-10-B (with top thread)	36	3.41.10B

Elementos de Conexión
Connecting Elements

Barra de conexión (roscada)
Linear Bar Connector (with top thread)

Material: Acero zincado / *Zinc plated steel*

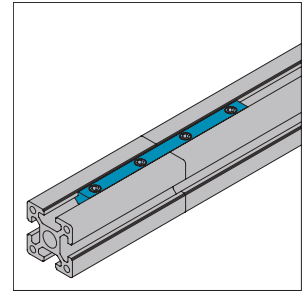

Linear Bar Connector-6

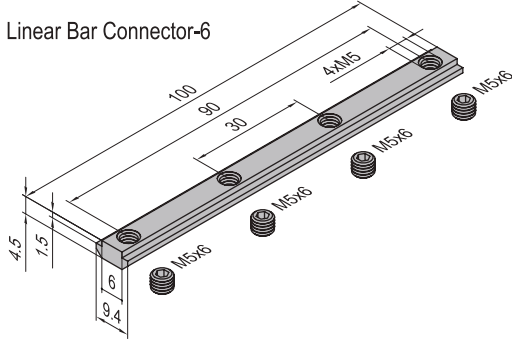

Linear Bar Connector-8

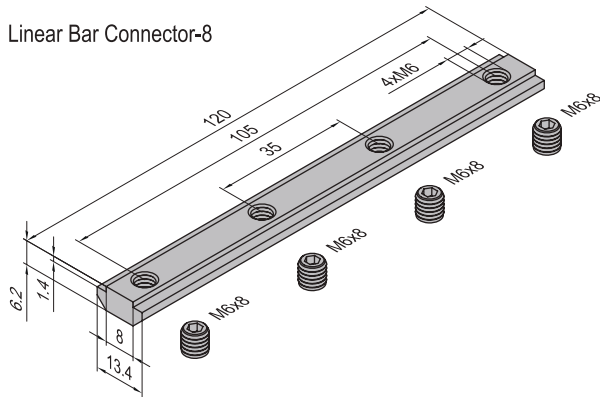

Linear Bar Connector-10

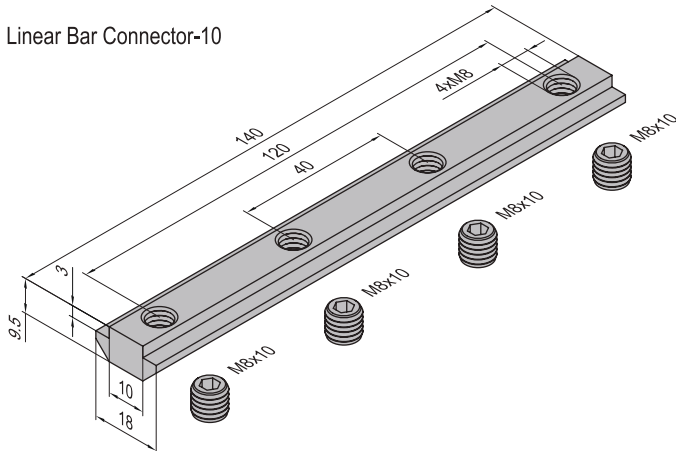

Descripción	Masa (g/pcs)	Part No.
Linear Bar Connector-6 (with top thread)	27	3.51.06
Linear Bar Connector-8 (with top thread)	65	3.51.08
Linear Bar Connector-10 (with top thread)	132	3.51.10

Elementos de Conexión
Connecting Elements

Barra de conexión (roscada)
Linear Bar Connector (with top thread)

Material: Acero zincado / *Zinc plated steel*

Linear Bar Connector-8

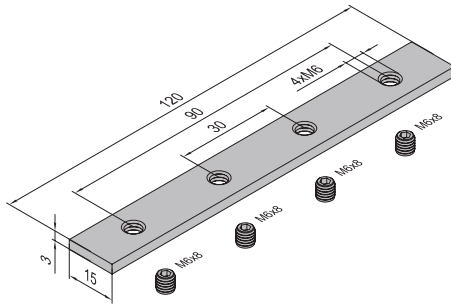
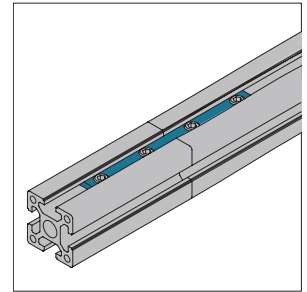

Descripción	Masa (g/pcs)	Part No.
Linear Bar Connector-8 (with top thread)	40	3.52.08
Linear Bar Connector-10 (with top thread)	74	3.52.10



Linear Bar Connector-10

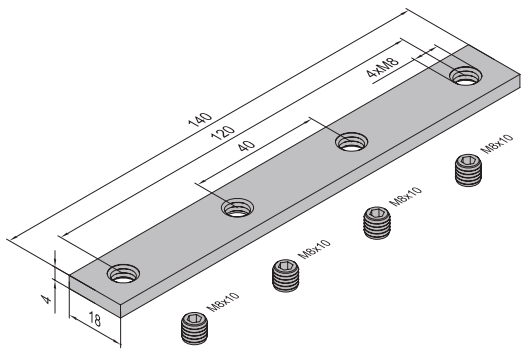

Elementos de Conexión
Connecting Elements

Platina de Unión
Joining Plate

Material: Acero zincado / *Zinc plated steel*

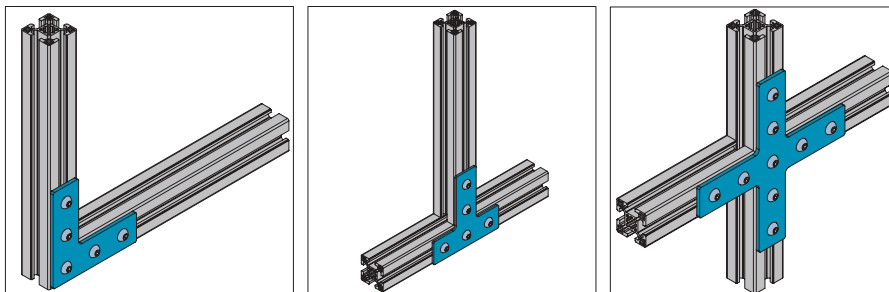

PG40-4040-01

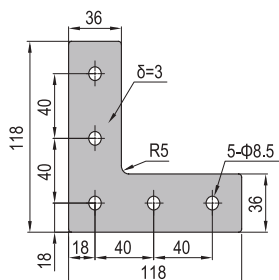

X	Fastening Set	Y	Fastening Set
	M8x12 Bolt zinc plated		M8x12 Bolt zinc plated
	M8 Washer zinc plated		M8 Washer zinc plated
	M8T Nut nickel plated		M8 Pre-set Nut nickel plated

PG40-4040-02

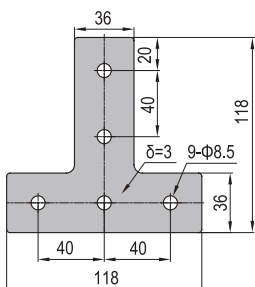

PG40-4040-03

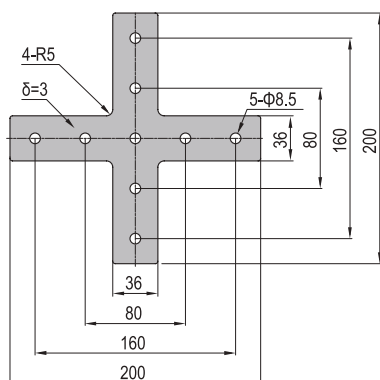

Descripción	Fastening Set	Masa (g)	Part No.
PG40-4040-01 (pcs)		219	3.53.40.4040.01
PG40-4040-01 (set X)	5xX	304	3.53.40.4040.01.STX
PG40-4040-01 (set Y)	5xY	349	3.53.40.4040.01.STY
PG40-4040-02 (pcs)		220	3.53.40.4040.02
PG40-4040-02 (set X)	5xX	305	3.53.40.4040.02.STX
PG40-4040-02 (set Y)	5xY	350	3.53.40.4040.02.STY
PG40-4040-03 (pcs)		400	3.53.40.4040.03
PG40-4040-03 (set X)	9xX	553	3.53.40.4040.03.STX
PG40-4040-03 (set Y)	9xY	634	3.53.40.4040.03.STY

Elementos de Conexión
Connecting Elements

Platina de Unión
Joining Plate

Material: Acero zincado / *Zinc plated steel*

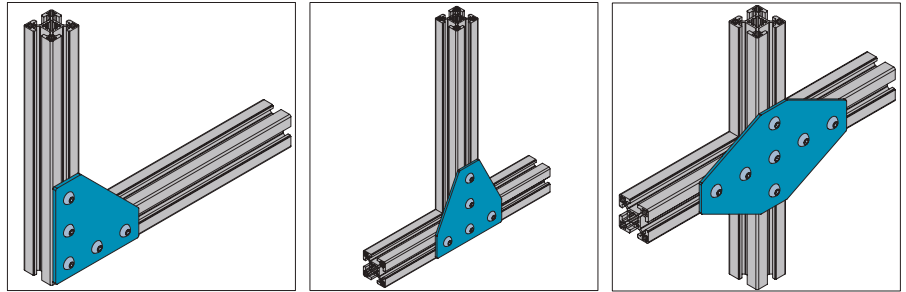

PG40-4040-04

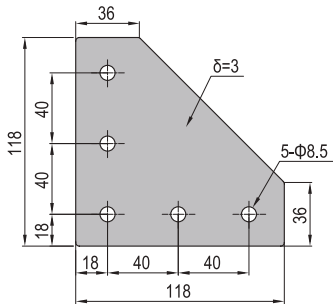

X	Fastening Set	Y	Fastening Set
	M8x12 Bolt zinc plated		M8x12 Bolt zinc plated
	M8 Washer zinc plated		M8 Washer zinc plated
	M8T Nut nickel plated		M8 Pre-set Nut nickel plated

PG40-4040-05

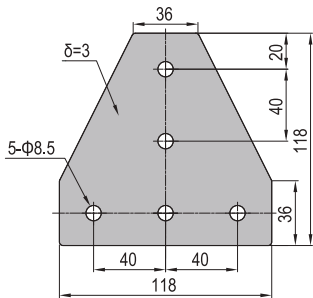

PG40-4040-06

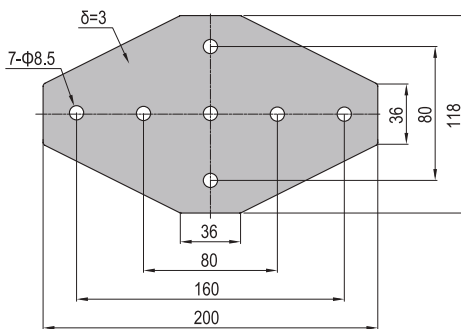

Descripción	Fastening Set	Masa (g)	Part No.
PG40-4040-04 (pcs)		324	3.53.40.4040.04
PG40-40x40-04 (set X)	5xX	409	3.53.40.4040.04.STX
PG40-4040-04 (set Y)	5xY	454	3.53.40.4040.04.STY
PG40-4040-05 (pcs)		324	3.53.40.4040.05
PG40-4040-05 (set X)	5xX	409	3.53.40.4040.05.STX
PG40-4040-05 (set Y)	5xY	454	3.53.40.4040.05.STY
PG40-4040-06 (pcs)		518	3.53.40.4040.06
PG40-4040-06 (set X)	7xX	637	3.53.40.4040.06.STX
PG40-4040-06 (set Y)	7xY	700	3.53.40.4040.06.STY

Elementos de Conexión
Connecting Elements

Platina de Unión
Joining Plate

Material: Acero zincado / *Zinc plated steel*

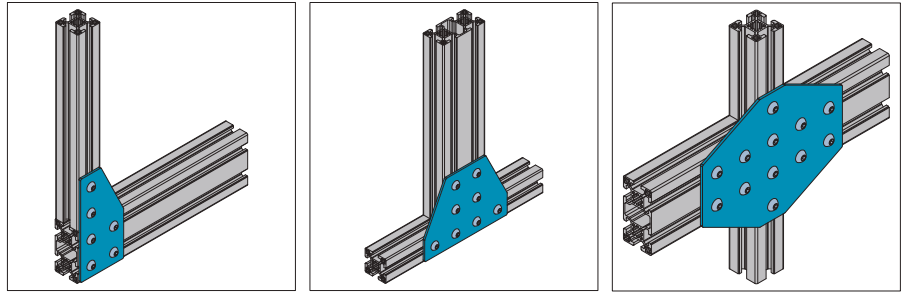

PG40-4080-01

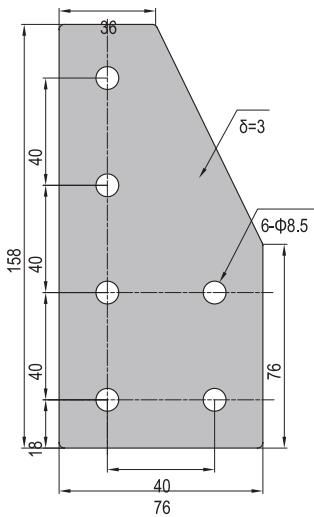

PG40-4080-03

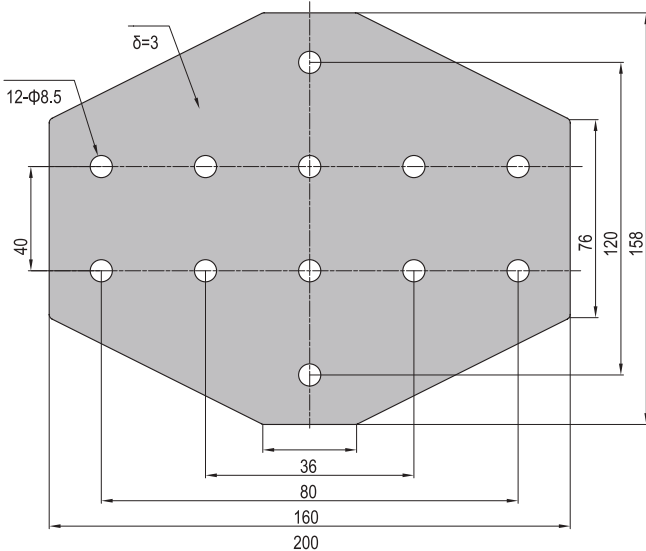

PG40-4080-02

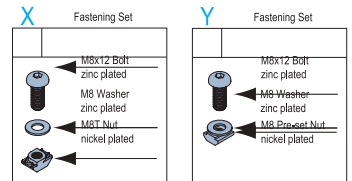
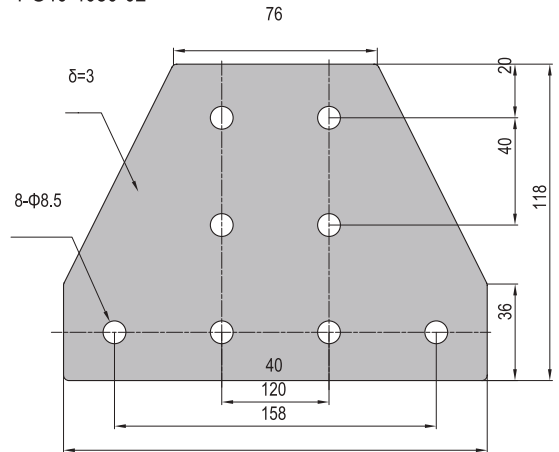

Descripción	Fastening Set	Masa (g)	Part No.
PG40-4080-01 (pcs)		315	3.53.40.4080.01
PG40-4080-01 (set X)	6xX	417	3.53.40.4080.01.STX
PG40-4080-01 (set Y)	6xY	471	3.53.40.4080.01.STY
PG40-4080-02 (pcs)		466	3.53.40.4080.02
PG40-4080-02 (set X)	8xX	602	3.53.40.4080.02.STX
PG40-4080-02 (set Y)	8xY	674	3.53.40.4080.02.STY
PG40-4080-03 (pcs)		762	3.53.40.4080.03
PG40-4080-03 (set X)	12xX	966	3.53.40.4080.03.STX
PG40-4080-03 (set Y)	12xY	1074	3.53.40.4080.03.STY

Elementos de Conexión

Connecting Elements

Platina de Unión

Joining Plate

Material: Acero zincado / *Zinc plated steel*

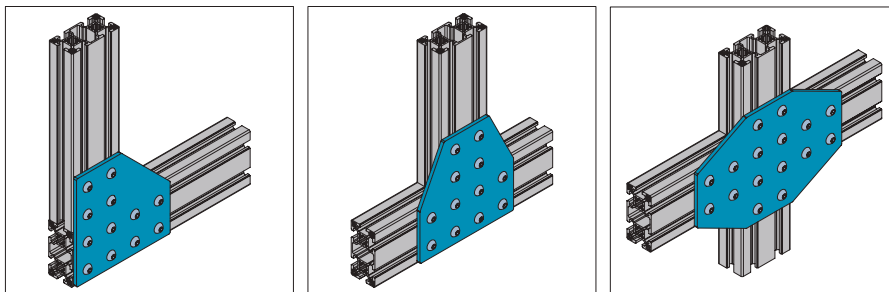

PG40-8080-01

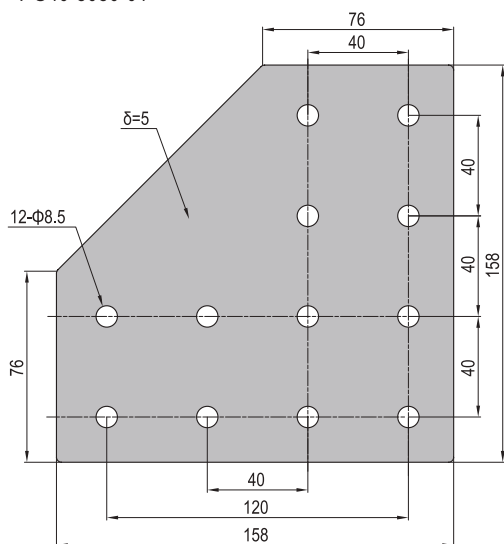

PG40-8080-02

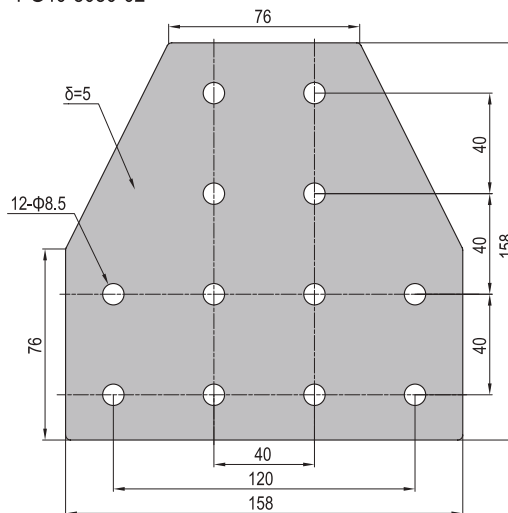

PG40-8080-03

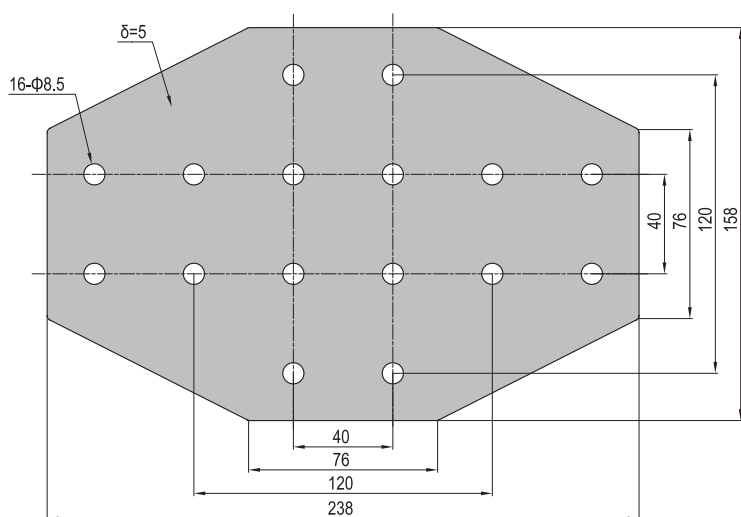

I	Fastening Set	O	Fastening Set
	M8x16 Bolt zinc plated		M8x16 Bolt zinc plated
	M8 Washer zinc plated		M8 Washer zinc plated
	M8T Nut nickel plated		M8 Pre-set Nut nickel plated

Descripción	Fastening Set	Masa (g)	Part No.
PG40-8080-01 (pcs)		656	3.53.40.8080.01
PG40-8080-01 (set I)	12xI	879	3.53.40.8080.01.STI
PG40-8080-01 (set O)	12xO	987	3.53.40.8080.01.STO
PG40-8080-02 (pcs)		656	3.53.40.8080.02
PG40-8080-02 (set I)	12xI	879	3.53.40.8080.02.STI
PG40-8080-02 (set O)	12xO	987	3.53.40.8080.02.STO
PG40-8080-03 (pcs)		945	3.53.40.8080.03
PG40-8080-03 (set I)	16xI	1242	3.53.40.8080.03.STI
PG40-8080-03 (set O)	16xO	1386	3.53.40.8080.03.STO

Elementos de Conexión

Connecting Elements

Conector de Tope
Butt Connectors

Los Conectores de Tope son utilizados extensamente para la unión de perfiles en sistemas de sala blanca o sala limpia.
Butt Connector is used widely used to connect profiles for clean room systems.

Material: Fundición de zinc niquelada / *Die Cast Zinc nickel plated*



Butt Connector-8

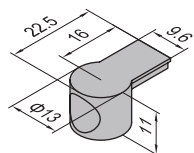

Butt Connector-10

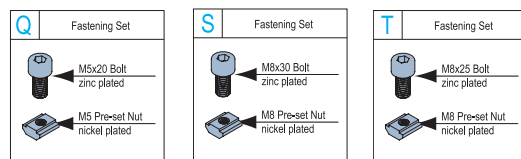
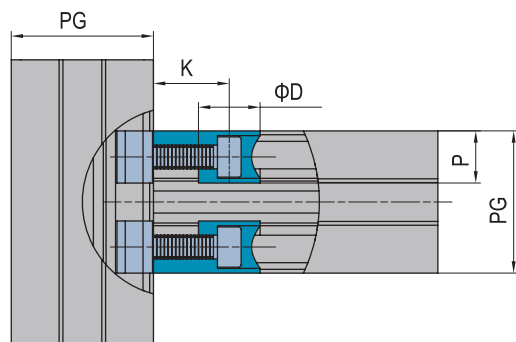
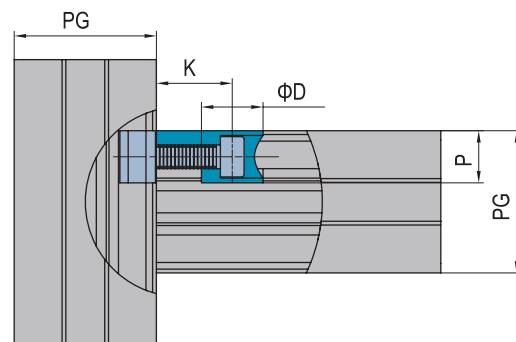
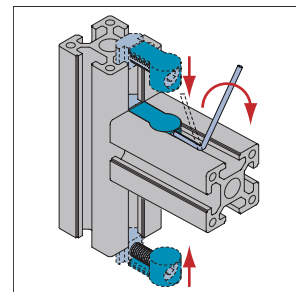
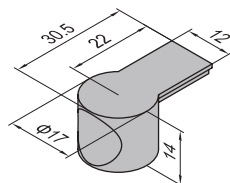

Descripción	PG	K (mm)	D (mm)	P (mm)	Fastening Set	Masa (g)	Part No.
Butt Connector-8 (pcs)	PG30	16	13	11		9	3.61.08
Butt Connector-8 (set)	PG30	16	13	11	1xQ	20	3.61.08.ST
Butt Connector-10 (pcs)	PG40/PG45/PG50/PG60	22	17	14		15	3.61.10
Butt Connector-10-4 (set)	PG40	22	17	14	1xT	41	3.61.10.04.ST
Butt Connector-10-6 (set)	PG45/PG50/PG60	22	17	14	1xS	43	3.61.10.06.ST

Elementos de Conexión

Connecting Elements

Conector de Extremo End Connectors

Los Conectores de Extremo también llamados conectores tipo botón mariposa por su forma, pueden ser escondidos completamente en el perfil de aluminio. Son utilizados extensamente para la unión de perfiles en sistemas de sala limpia.
End Connector is also called Butterfly Button Connector due to its shape. It is hidden completely inside the profile so it is frequently used for clean room systems.

Material: Acero niquelado / *Nickel plated steel*



End Connector-8

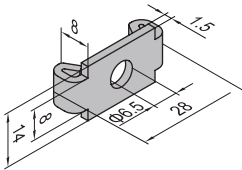

End Connector-10

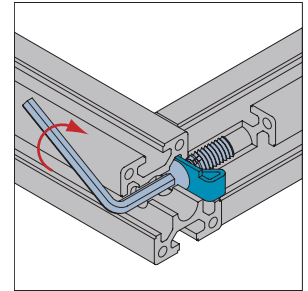
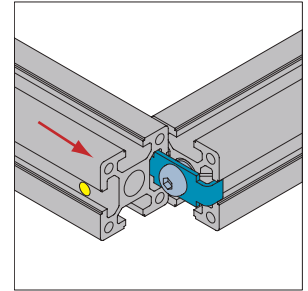
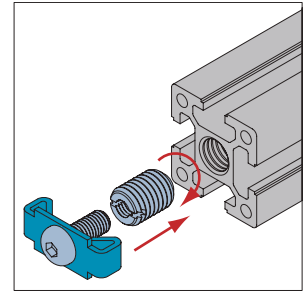
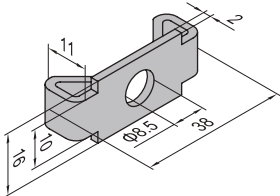

Descripción	PG	Fastening Set	Masa (g)	Part No.
End Connector-8 (pcs)	PG30		7	3.71.30
End Connector-8 (set)	PG30	1xFA	23	3.71.30.ST
End Connector-10 (pcs)	PG40		13	3.71.40
End Connector-10 (set)	PG40	1xFB	38	3.71.40.ST

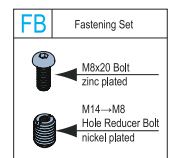
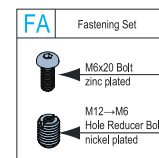

Elementos de Conexión
Connecting Elements

Conector de Tornillo
Screw Connectors

Los Conectores de Tornillo son una forma simple y económica de reemplazar los Conectores de extremo proporcionando una conexión de mayor confiabilidad.
Screw Connector is a simple and easy way to replace the End Connectors with more connection reliability.

Material: Acero niquelado / *Niquel plated steel*



Screw Connector-6

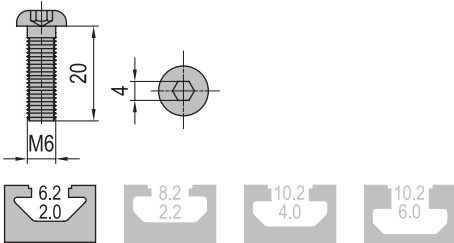

Screw Connector-8

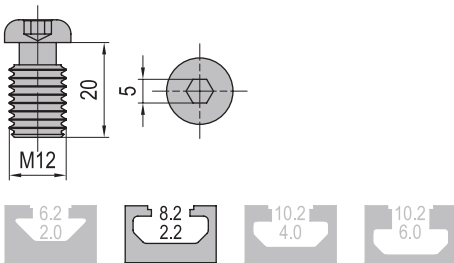

Screw Connector-10

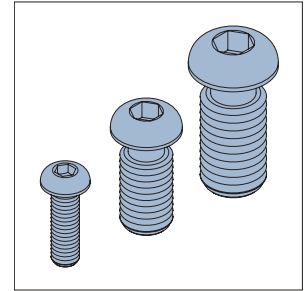
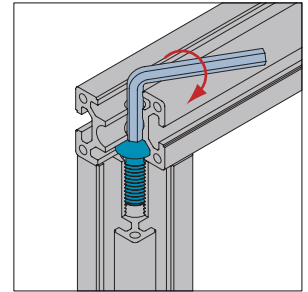
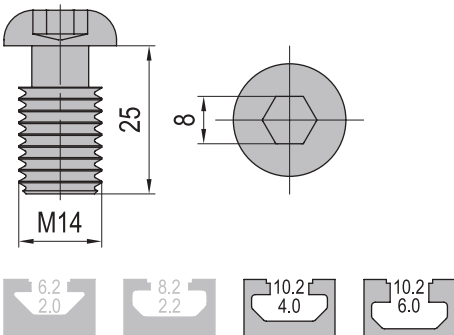

Descripción	Masa (g)	Part No.
Screw Connector-6	7	3.81.06
Screw Connector-8	17	3.81.08
Screw Connector-10	31	3.81.10

Elementos de Conexión
Connecting Elements

Conector Cúbico

Cubic Connector

Material: Conector-fundición de aluminio ; tapa-ABS negro

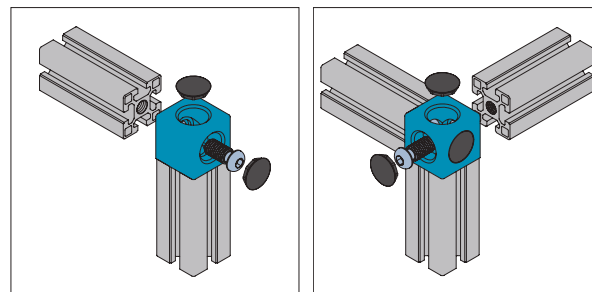
Connector-Die Case Aluminium ; Cap-ABS black

Cubic Connector-4545-2

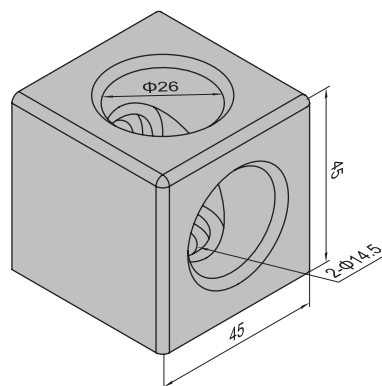

Cubic Connector-4545-3

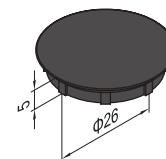
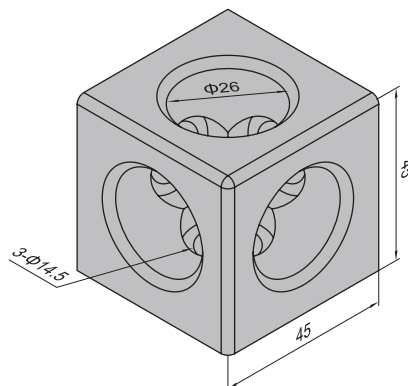

Descripción	Fastening Set	Cap (pcs)	Masa (g)	Part No.
Cubic Connector-4545-2 (pc)		2	135	3.91.4545.02
Cubic Connector-4545-2 (set)	2x(M14x25)	2	201	3.91.4545.02.ST
Cubic Connector-4545-3 (pc)		3	135	3.91.4545.03
Cubic Connector-4545-3 (set)	3x(M14x25)	3	234	3.91.4545.03.ST

Elementos de Conexión *Connecting Elements*

Conector Cúbico
Cubic Connector

Material: Fundición de zinc / Die Case Zinc

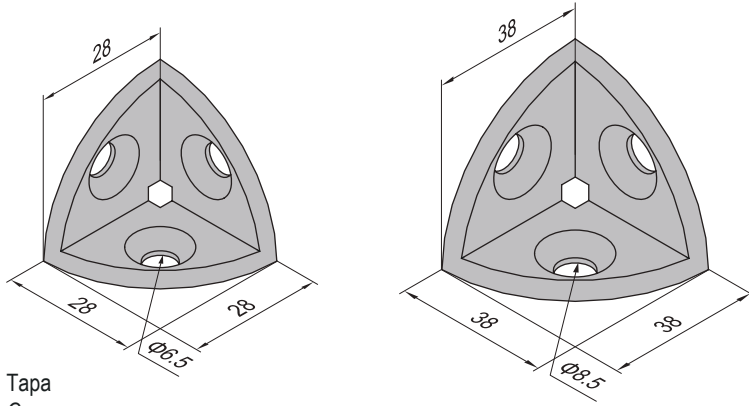

Tapa
Cap

Material y color: ABS negro

3030-01

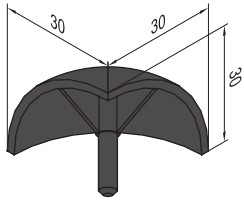

3030-02

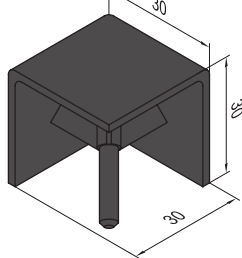

4040-01

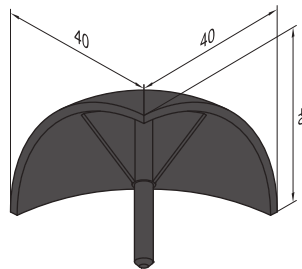

4040-02

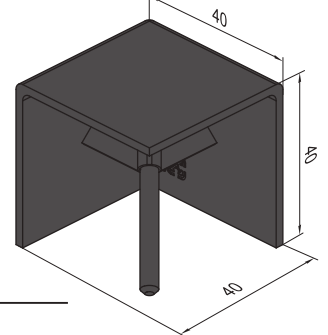

Descripción	Fastening Set	Cap (pcs)	Masa (g)	Part No.
Cubic Connector-3030-01 (pc)		1	35	3.92.3030.01
Cubic Connector-3030-01(set)	3xCW	1	105	3.92.3030.01.ST
Cubic Connector-3030-02 (pc)		1	38	3.92.3030.02
Cubic Connector-3030-02 (set)	3xCW	1	108	3.92.3030.02.ST
Cubic Connector-4040-01 (pc)		1	87	3.92.4040.01
Cubic Connector-4040-01(set)	3xFI	1	159	3.92.4040.01.ST
Cubic Connector-4040-02 (pc)		1	92	3.92.4040.02
Cubic Connector-4040-02 (set)	3xFI	1	164	3.92.4040.02.ST

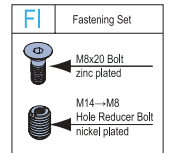
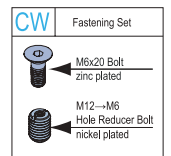

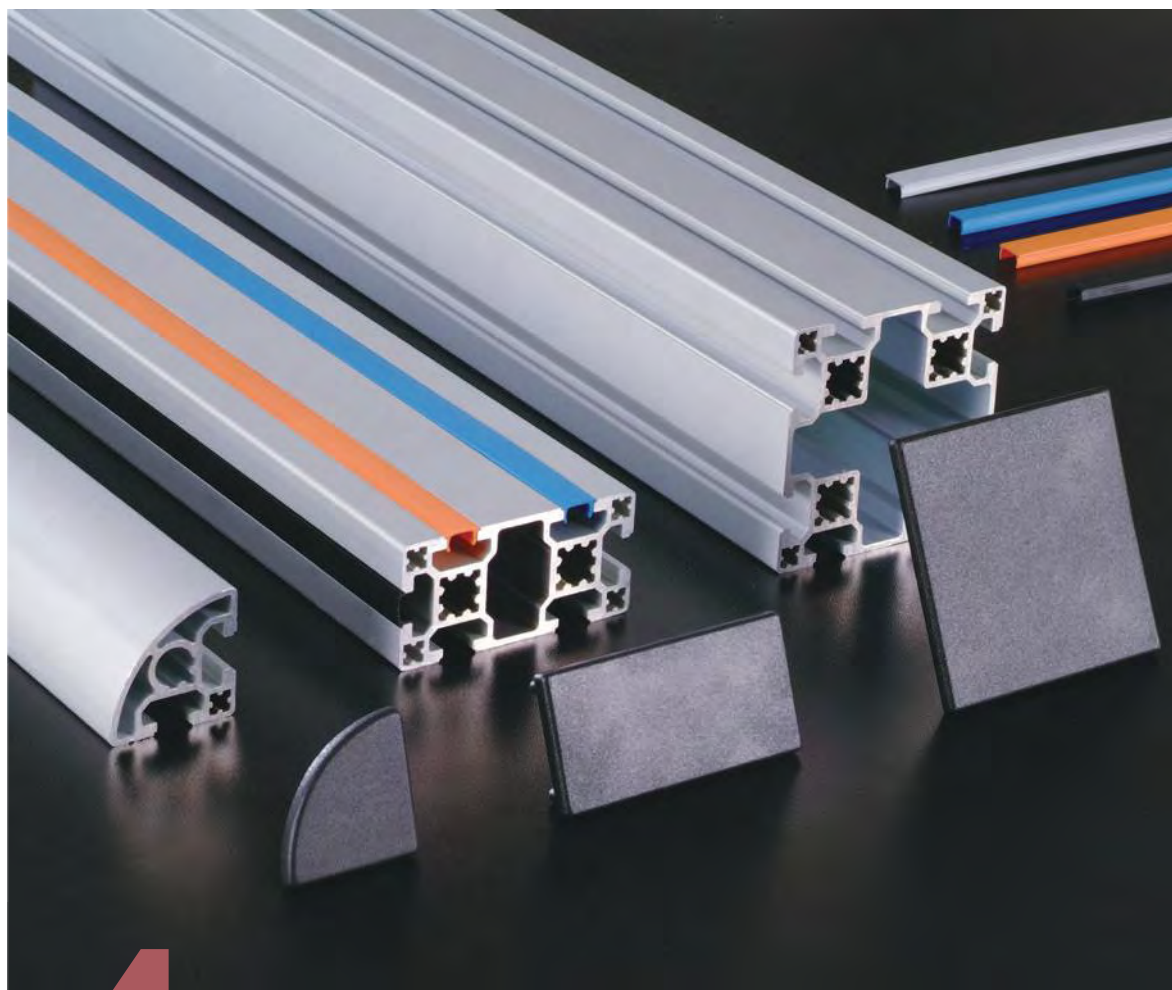

4.11-4.21

Tapas de Extremo
End Cap

Cobertor de ranura T
T Slot Cover

4

Accesorios de Perfiles *Profile Accessories*

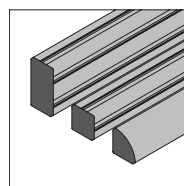

4.11

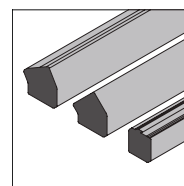

4.12

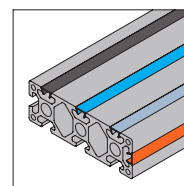

4.21.01

Accesorios de Perfiles

Profile Accessories

Tapa de Extremo

End Cap

La Tapa de Extremo sirve para ocultar bordes filosos y para mejorar la apariencia y terminación de la estructura.

End Cap prevents staff from any injury and improve profile end appearance.

Material y color: ABS negro / black

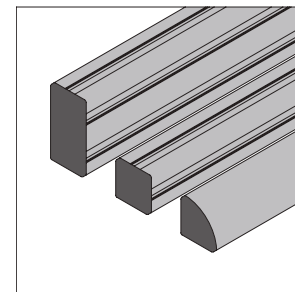

Type A

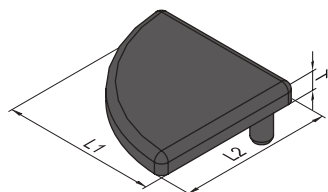

Type B

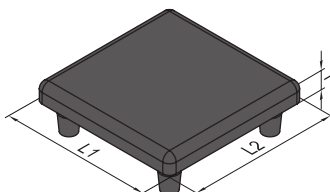

Type C

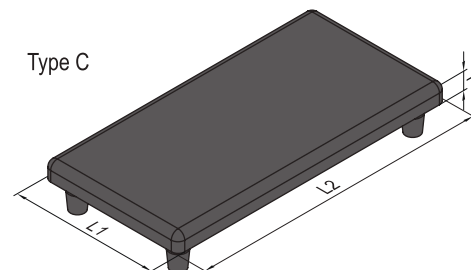

	Descripción	L1 (mm)	L2 (mm)	T (mm)	Masa (g)	Part No.
Type A	End Cap-PG30-3030R	30	30	5	3	4.11.30.3030R
	End Cap-PG40-4040R	40	40	5	6	4.11.40.4040R
	End Cap-PG45-4545R	45	45	5	7	4.11.45.4545R
Type B	End Cap-PG15-1515	15	15	3	1	4.11.15.1515
	End Cap-PG20-2020	20	20	4	2	4.11.20.2020
	End Cap-PG20-4040	40	40	4	6	4.11.20.4040
	End Cap-PG30-3030	30	30	5	3	4.11.30.3030
	End Cap-PG30-6060	60	60	5	15	4.11.30.6060
	End Cap-PG40-4040	40	40	5	6	4.11.40.4040
	End Cap-PG40-8080	80	80	5	22	4.11.40.8080
	End Cap-PG40-120120	120	120	5	64	4.11.40.120120
	End Cap-PG45-4545	45	45	5	8	4.11.45.4545
	End Cap-PG45-9090	90	90	5	28	4.11.45.9090
	End Cap-PG50-5050	50	50	5	10	4.11.50.5050
	End Cap-PG50-100100	100	100	5	44	4.11.50.100100
	End Cap-PG60-6060	60	60	5	14	4.11.60.6060
Type C	End Cap-PG15-1530	15	30	3	1.1	4.11.15.1530
	End Cap-PG20-2040	20	40	4	3	4.11.20.2040
	End Cap-PG20-2060	20	60	4	4	4.11.20.2060
	End Cap-PG20-2080	20	80	4	5	4.11.20.2080
	End Cap-PG30-3060	30	60	5	8	4.11.30.3060
	End Cap-PG30-3090	30	90	5	11	4.11.30.3090
	End Cap-PG30-30120	30	120	5	14	4.11.30.30120
	End Cap-PG30-60120	60	120	5	33	4.11.30.60120
	End Cap-PG40-4060	40	60	5	9	4.11.40.4060
	End Cap-PG40-4080	40	80	5	13	4.11.40.4080
End Cap-PG40-40120	40	120	5	18	4.11.40.40120	

Accesorios de Perfiles

Profile Accessories

Tapa de Extremo

End Cap

La Tapa de Extremo sirve para ocultar bordes filosos y para mejorar la apariencia y terminación de la estructura.

End Cap prevents staff from any injury and improve profile end appearance.

Material y color: ABS negro / black

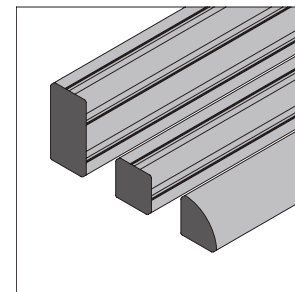

Type C

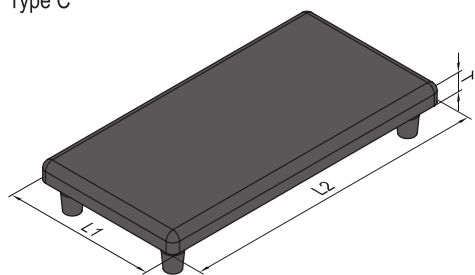

Type D

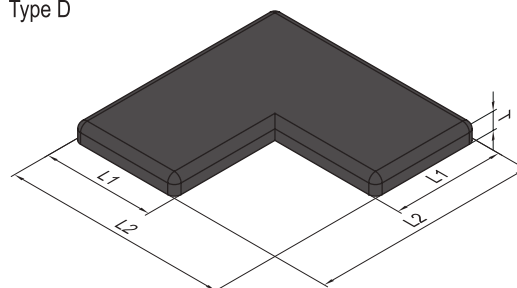

Descripción		L1 (mm)	L2 (mm)	T (mm)	Masa (g)	Part No.
Type C	End Cap-PG40-40160	40	160	5	24	4.11.40.40160
	End Cap-PG40-80120	80	120	5	43	4.11.40.80120
	End Cap-PG40-80160	80	160	5	58	4.11.40.80160
	End Cap-PG40-80200	80	200	5	72	4.11.40.80200
	End Cap-PG45-4560	45	60	5	11	4.11.45.4560
	End Cap-PG45-4590	45	90	5	16	4.11.45.4590
	End Cap-PG45-90180	90	180	5	72	4.11.45.90180
	End Cap-PG50-50100	50	100	5	18	4.11.50.50100
Type D	End Cap-PG30-6060L	30	60	5	11	4.11.30.6060L
	End Cap-PG40-8080L	40	80	5	17	4.11.40.8080L
	End Cap-PG45-9090L	45	90	5	22	4.11.45.9090L

Accesorios de Perfiles

Profile Accessories

Tapa de Extremo

End Cap

La Tapa de Extremo sirve para ocultar bordes filosos y mejorar la terminación de la estructura.

End Cap prevents staff from any injury and improve profile end appearance.

Material y color: ABS negro / black

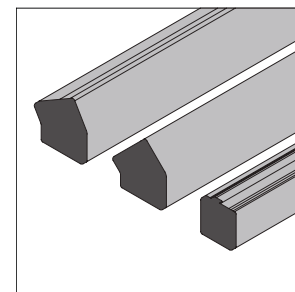

Type E

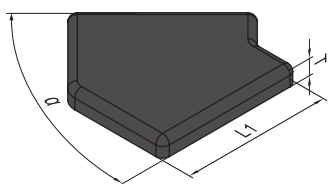

Type F

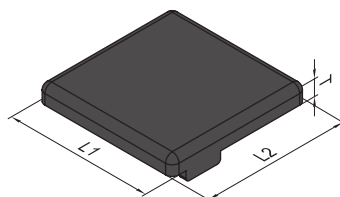

Type G

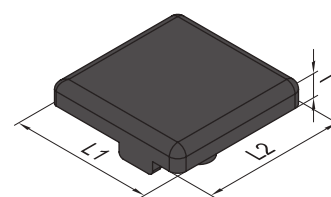

Descripción		L1 (mm)	$\alpha(^{\circ})/L2$ (mm)	T (mm)	Masa (g)	Part No.
Type E	End Cap-Clamping Profile-PG30-3030-R30	30	30	5	4	4.12.30.3030.R30
	End Cap-Clamping Profile-PG30-3030-R45	30	45	5	4	4.12.30.3030.R45
	End Cap-Clamping Profile-PG30-3030-R60	30	60	5	4	4.12.30.3030.R60
	End Cap-Clamping Profile-PG40-4040-R30	40	30	5	6	4.12.40.4040.R30
	End Cap-Clamping Profile-PG40-4040-R45	40	45	5	6	4.12.40.4040.R45
	End Cap-Clamping Profile-PG40-4040-R60	40	60	5	6	4.12.40.4040.R60
Type F	End Cap-Clamping Profile-PG30-3030	30	30	5	4	4.12.30.3030
	End Cap-Clamping Profile-PG40-4040	40	40	5	6	4.12.40.4040
Type G	End Cap-Protective Grille Profile-PG30-3030	30	30	5	4	4.13.30.3030
	End Cap-Protective Grille Profile-PG40-4040	40	40	5	6	4.13.40.4040

Accesorios de Perfiles

Profile Accessories

Cobertor de ranura T

T Slot Cover

El Cobertor de Ranura T se utiliza para prevenir acumulación de suciedad en la ranura T y para mejorar la apariencia y terminación de la estructura.

T Slot Cover is used to prevent dust buildup inside the slot and to improve structure appearance.

Material y color: PP negro, azul, gris, naranja / PP black, blue, grey, orange

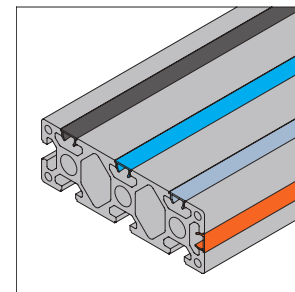

T Slot Cover-6

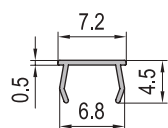

T Slot Cover-8

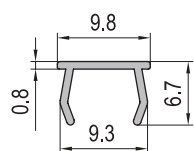

T Slot Cover-10

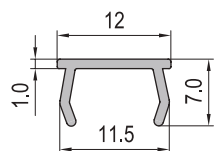

Descripción	Color	Masa (g)	Largo	Part No.
T Slot Cover-6	Black	11	2000mm/bar	4.21.06.BK
T Slot Cover-6	Blue	11	2000mm/bar	4.21.06.BE
T Slot Cover-6	Grey	11	2000mm/bar	4.21.06.GY
T Slot Cover-6	Safety Orange	11	2000mm/bar	4.21.06.SE
T Slot Cover-8	Black	22	2000mm/bar	4.21.08.BK
T Slot Cover-8	Blue	22	2000mm/bar	4.21.08.BE
T Slot Cover-8	Grey	22	2000mm/bar	4.21.08.GY
T Slot Cover-8	Safety Orange	22	2000mm/bar	4.21.08.SE
T Slot Cover-10	Black	38	2000mm/bar	4.21.10.BK
T Slot Cover-10	Blue	38	2000mm/bar	4.21.10.BE
T Slot Cover-10	Grey	38	2000mm/bar	4.21.10.GY
T Slot Cover-10	Safety Orange	38	2000mm/bar	4.21.10.SE



5.11-5.61

Platina de Base
Base Plate

Pata de Nivelación
Leveling Foot

Platina de Pata de Nivelación
Mounting Plate

Platinas de Ruedas Giratorias
Caster Wheel Plate

Ruedas Giratorias
Caster Wheel

Ángulo de Refuerzo
Base Angle

Base con Pata y Rueda Giratoria
Foot and Caster Components

5

Elementos de Apoyo Floor Elements

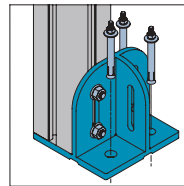

5.11.01

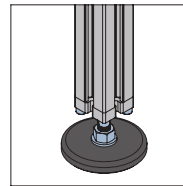

5.21-24

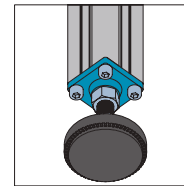

5.31.01

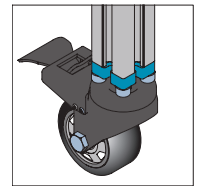

5.32-33

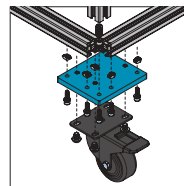

5.34-35

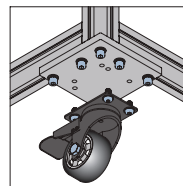

5.41.01

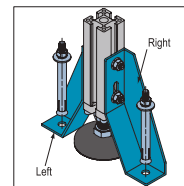

5.51.01

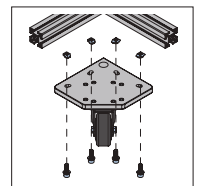

5.61.01

Elementos de Apoyo

Floor Elements

Platina Base

Base Plate

La Platina Base permite fijar las patas de la estructura al suelo mediante la utilización de tacos de expansión.

Base Plate is used to anchor the structure stand supports to the floor using expansion bolts.

Material y color: Acero al carbono con terminación de pintura electrostática negro

Mild steel with powder coating black

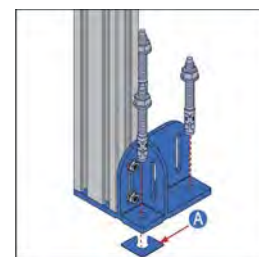

Base Plate-4080

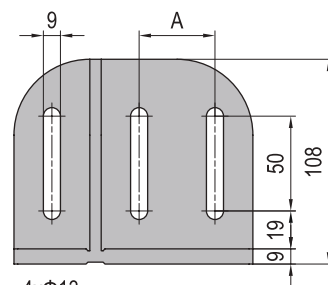
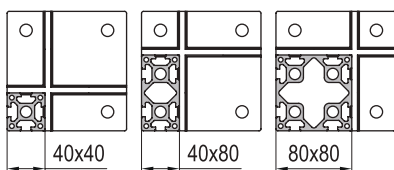
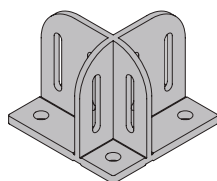

Base Plate-4560

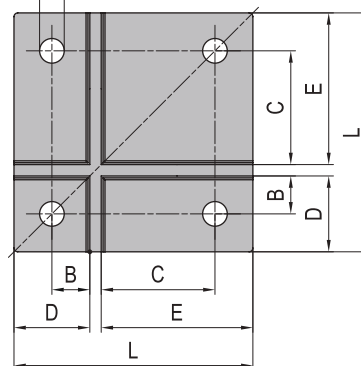
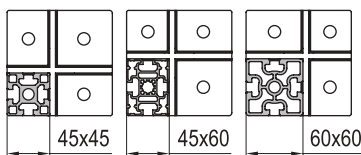
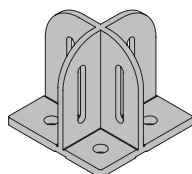

Base Plate-4590

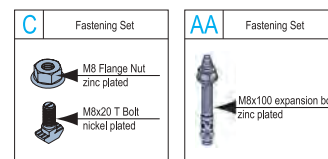
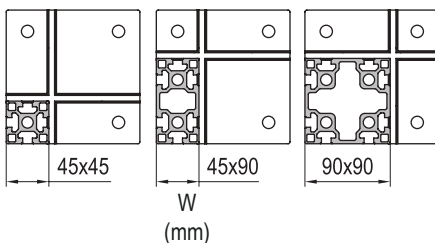
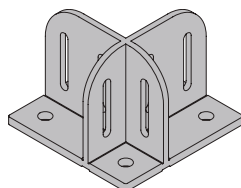

Descripción	L (mm)	A (mm)	B (mm)	C (mm)	D (mm)	E (mm)	Fastening Set	Masa (g)	Part No.
Base Plate-4080 (pcs)	126	40	20	60	40	80		1930	5.11.4080
Base Plate-4080 (set A)							4x C +3x AA	2240	5.11.4080.STA
Base Plate-4080 (set B)							6x C +3x AA	2290	5.11.4080.STB
Base Plate-4080 (set C)							8x C +3x AA	2340	5.11.4080.STC
Base Plate-4560 (pcs)	111		22.5	30	45	60		1600	5.11.4560
Base Plate-4560 (set)							4x C +3x AA	1910	5.11.4560.ST
Base Plate-4590 (pcs)	141	45	22.5	67.5	45	90		2330	5.11.4590
Base Plate-4590 (set A)							4x C +3x AA	2640	5.11.4590.STA
Base Plate-4590 (set B)							6x C +3x AA	2690	5.11.4590.STB
Base Plate-4590 (set C)							8x C +3x AA	2740	5.11.4590.STC

Elementos de Apoyo
Floor Elements

Platina Base
Base Plate

La Platina Base permite fijar las patas de la estructura al suelo mediante la utilización de tacos de expansión.
Base Plate is used to anchor the structure stand supports to the floor using expansion bolts.

Material y color: Fundición de hierro con terminación de pintura electrostática gris
Die Cast Steel with powder coating grey

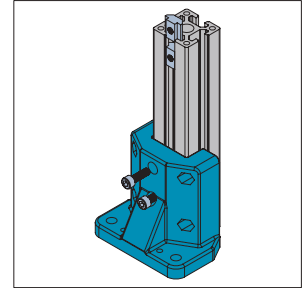

Base Plate-40-A

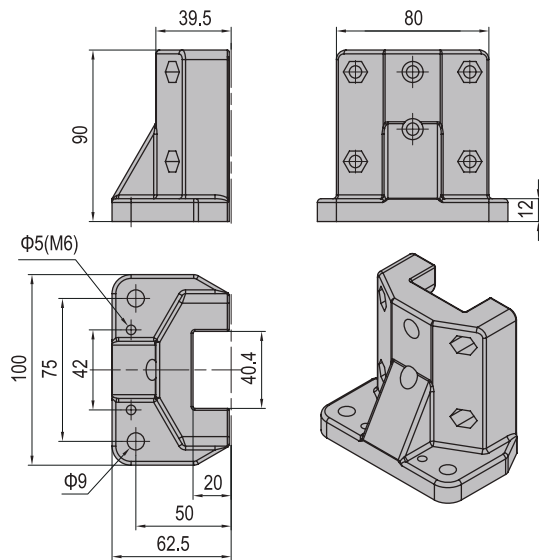

HV Fastening Set	
	M6x20 Bolt zinc plated
	M6 Pre-set Nut nickel plated

Descripción	Fastening Set	Masa (g)	Part No.
Base Plate-4040 (pc)		445	5.12.4040.PC
Base Plate-4040 (set)	2xHV	490	5.12.4040.STA

Base Plate-40-B

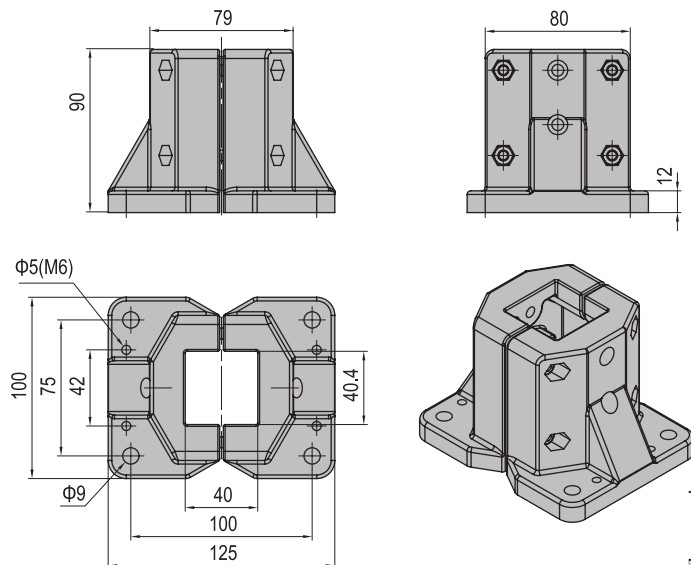

HT Fastening Set	
	M6x45 Bolt zinc plated
	M6 Hex nuts zinc plated

Descripción	Fastening Set	Masa (g)	Part No.
Base Plate-4040 (set)	4xHT	945	5.12.4040.STB

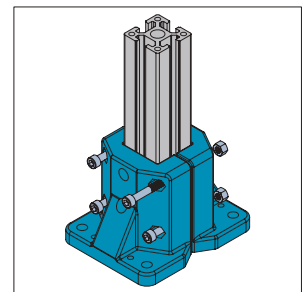

Elementos de Apoyo
Floor Elements

Platina Base
Base Plate

La Platina Base permite fijar las patas de la estructura al suelo mediante la utilización de tacos de expansión.
Base Plate is used to anchor the structure stand supports to the floor using expansion bolts.

Material y color: Fundición de hierro con terminación de pintura electrostática gris
Die Cast Steel with powder coating grey

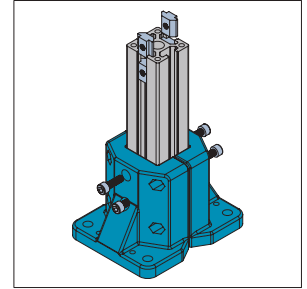

Base Plate-40-C

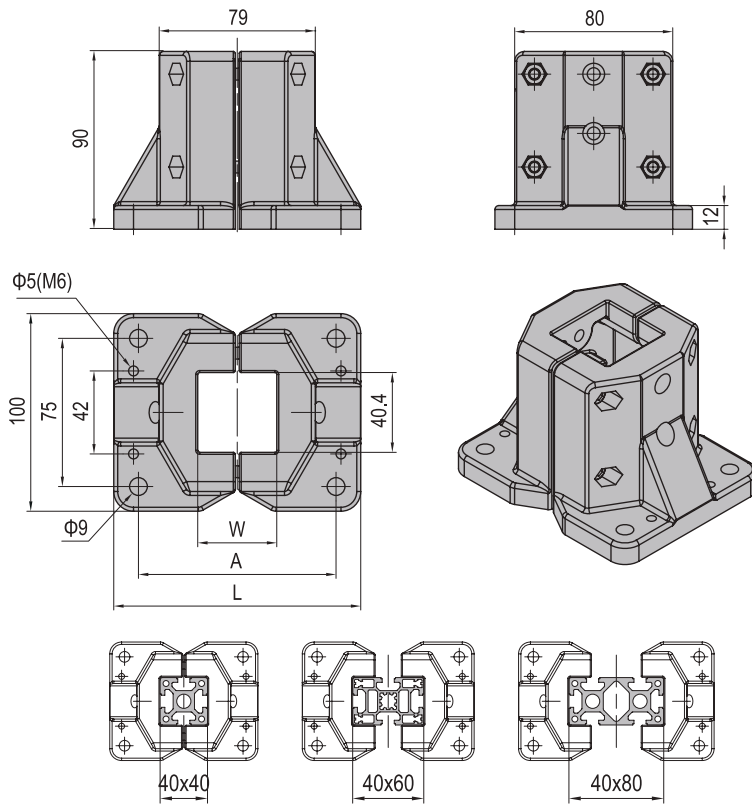

Descripción	W (mm)	A (mm)	L (mm)	Fastening Set	Masa (g)	Part No.
Base Plate-4040 (set)	40	100	125	4xHV	975	5.12.4040.STC
Base Plate-4060 (set)	60	120	145	4xHV	975	
Base Plate-4080 (set)	80	140	165	4xHV	975	

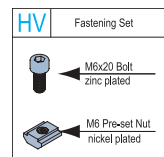

Elementos de Apoyo

Floor Elements

Pata tipo Pivot

Pivot Foot

La Pata tipo Pivot permite apoyar la estructura en zonas que requieren un ajuste gradual de altura. El pequeño ángulo de rotación absorbe las irregularidades del suelo. La conexión entre la base y la varilla roscada se puede desarmar mediante el uso de una herramienta.

The Pivot Foot is used to support the structure where gradual height adjustment is needed. The small swivel angle can absorb the slope of uneven floor. The connection between the pivot base and the spindle can be released with a tool.

Material y color: Varilla roscada-acero al carbono zincado / base-PA6 negro

Spindle-Zinc Plated Steel / Base-PA6 black

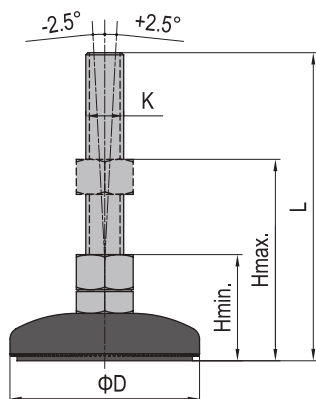

Descripción	D (mm)	K x L (mm)	H mín. (mm)	H máx. (mm)	Carga Estática máx. (N)	Masa (g)	Part No.
Pivot Foot-PA 6 Base	59	M12x90	45	70	10000	152	5.21.60.12.90
	79	M12x90	45	70	10000	188	5.21.80.12.90
	79	M12x130	45	100	10000	218	5.21.80.12.130
	79	M16x130	45	100	10000	328	5.21.80.16.130
	99	M12x130	45	100	10000	326	5.21.100.12.130
	99	M16x130	45	100	10000	436	5.21.100.16.130

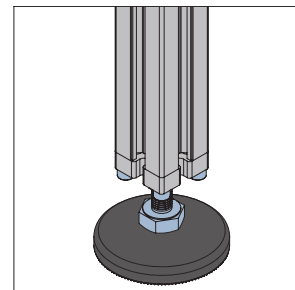

Pata tipo Giratoria

Swivel Foot

La Pata tipo Giratoria permite apoyar la estructura en zonas que requieren un ajuste gradual de altura y donde las irregularidades del suelo son grandes. La misma posee una rótula entre la varilla roscada y la base que hace que gire hasta un ángulo de 30°. Son muy útiles en instalaciones donde los equipos se mueven regularmente.

The Swivel Foot is used to support the structure where gradual height adjustment is needed and where the floor slope is significant. The Swivel Foot has a ball joint between the base and the spindle that allows the foot to swivel up to an angle of 30°.

Material y color: Varilla roscada-acero al carbono zincado / base-PA6 negro

Spindle-Zinc Plated Steel / Base-PA6 black

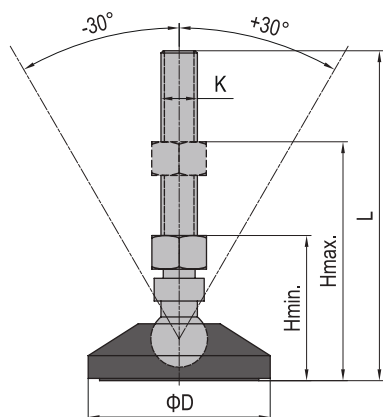

Descripción	D (mm)	K x L (mm)	H mín. (mm)	H máx. (mm)	Carga Estática máx. (N)	Masa (g)	Part No.
Swivel Foot-PA 6 Base	59	M12x90	45	70	10000	162	5.22.60.12.90
	79	M12x90	45	70	10000	198	5.22.80.12.90
	79	M12x130	45	100	10000	228	5.22.80.12.130
	79	M16x130	45	100	10000	338	5.22.80.16.130
	99	M12x130	45	100	10000	336	5.22.100.12.130
	99	M16x130	45	100	10000	446	5.22.100.16.130

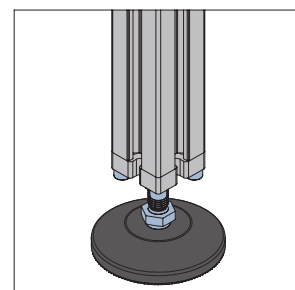

Elementos de Apoyo

Floor Elements

Pata Fija Fixed Foot

La Pata Fija permite apoyar la estructura en zonas que requieren un ajuste gradual de altura. La conexión entre la varilla roscada y la base es rígida.

The Pivot Foot is used to support the structure where gradual height adjustment is needed. The connection between the spindle and the base is fixed.

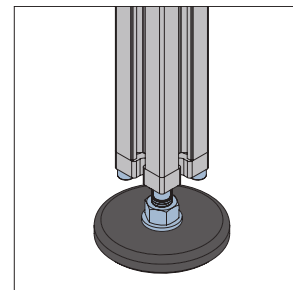

Material y Color: Varilla roscada-acero al carbono zincado / base-acero al carbono pintada mediante electroforesis color negro
Spindle-Zinc Plated Steel / Base-Mild Steel with black electrophoresis

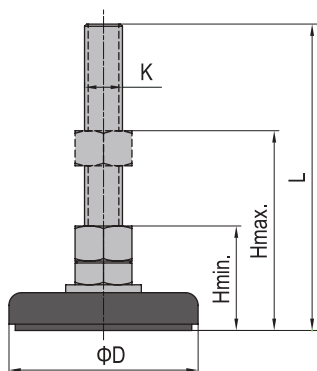

Descripción	D (mm)	K x L (mm)	H mín. (mm)	H máx. (mm)	Carga Estática máx. (N)	Masa (g)	Part No.
Fixed Foot-Steel Base	40	M12x70	35	50	8000	124	5.23.40.12.70
	60	M12x70	35	50	8000	181	5.23.60.12.70
	80	M12x70	35	50	8000	220	5.23.80.12.70
	80	M12x110	35	80	8000	240	5.23.80.12.110
	60	M14x70	38	50	6000	225	5.23.60.14.70
	80	M14x70	38	50	9000	283	5.23.80.14.70

Pata tipo Pivot Pivot Foot

La Pata tipo Pivot permite apoyar la estructura en zonas que requieren un ajuste gradual de altura. El pequeño ángulo de rotación absorbe las irregularidades del suelo. La conexión entre la base y la varilla roscada se puede desarmar mediante el uso de una herramienta.

The Pivot Foot is used to support the structure where gradual height adjustment is needed. The small swivel angle can absorb the slope of uneven floor. The connection between the pivot base and the spindle can be released with a tool.

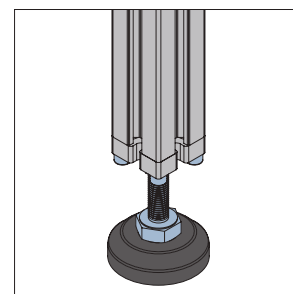

Material y color: Varilla roscada y base-acero al carbono zincado ó acero inoxidable / base-PA6 negro
Spindle and base-Zinc Plated Steel or Stainless Steel

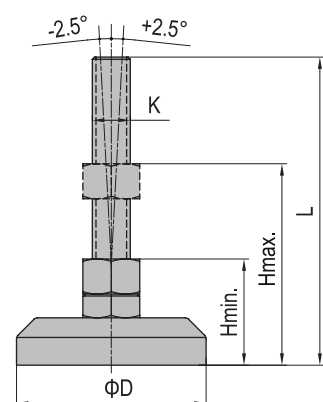

Descripción	D (mm)	K x L (mm)	H mín. (mm)	H máx. (mm)	Carga Estática máx. (N)	Masa (g)	Part No.
Pivot Foot-Zinc Plate Steel	40	M12x128	45	100	25000	241	5.24.40.12.130
	60	M12x128	45	100	25000	475	5.24.60.12.130
	60	M16x158	45	120	30000	596	5.24.60.16.160
	60	M20x178	50	130	35000	796	5.24.60.20.180
	80	M12x128	45	100	25000	670	5.24.80.12.130
	80	M16x158	45	120	30000	780	5.24.80.16.160
	80	M20x178	50	130	35000	945	5.24.80.20.180
Pivot Foot-Stainless Steel	40	M12x128	45	100	25000	240	5.24.40.12.130.SS
	60	M12x128	45	100	25000	480	5.24.60.12.130.SS
	60	M16x158	45	120	30000	600	5.24.60.16.160.SS
	60	M20x178	50	130	35000	803	5.24.60.20.180.SS
	80	M12x128	45	100	25000	675	5.24.80.12.130.SS
	80	M16x158	45	120	30000	785	5.24.80.16.160.SS
	80	M20x178	50	130	35000	950	5.24.80.20.180.SS

Elementos de Apoyo

Floor Elements

Platina de Montaje

Mounting Plate

La platina permite conectar la pata de nivelación al perfil de aluminio y mejorar la terminación de la estructura.

The Mounting Plate is used to attach the leveling foot to the profile and to improve the structure appearance.

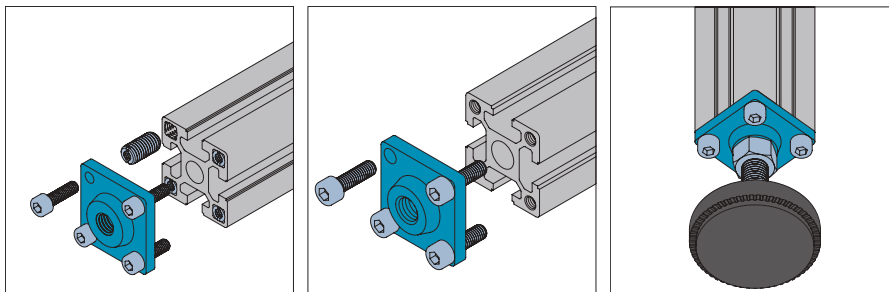

Material: Fundición de aluminio / Die Cast Aluminium



PG40-40x40

PG45-45x45

PG50-50x50



PG40-40x60

PG45-45x60

PG40-40x80

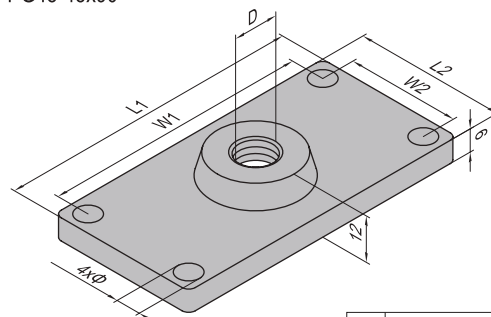
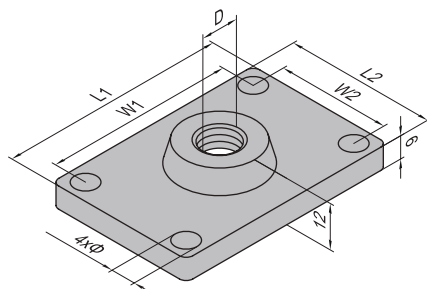
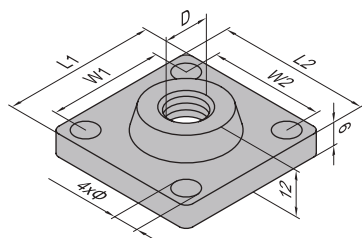
PG45-45x90



FC	Fastening Set
	M6x20 Bolt zinc plated
	M10-M6 Hole Reducer Bolt nickel plated

Aplicación	Descripción	D (mm)	Φ	L1 (mm)	L2 (mm)	W1 (mm)	W2 (mm)	Fastening Set	Masa (g)	Part No.
PG40-Profile 4040	PG40-4040	M12	6.5	40	40	30	30	4x(M6x20)	51	5.31.40.4040
PG45-Profile 4545	PG45-4545	M12		45	45	33	33	4xFC	97	5.31.45.4545
PG50-Profile 5050	PG50-5050	M12	8.5	50	50	35	35	4x(M8x30)	130	5.31.50.5050
PG40-Profile 4060	PG40-4060	M12	6.5	60	40	50	30	4x(M6x20)	67	5.31.40.4060
PG45-Profile 4560	PG45-4560	M12		60	45	48	33	4xFC	108	5.31.45.4560
PG40-Profile 4080	PG40-4080	M12		80	40	70	30	4x(M6x20)	78	5.31.40.4080.M12
		M16		4x(M6x20)	78	5.31.40.4080.M16				
PG45-Profile 4590	PG45-4590	M12	90	45	78	33	4xFC	131	5.31.45.4590.M12	
		M16					4xFC	128	5.31.45.4590.M16	

Elementos de Apoyo

Floor Elements

Platina de Montaje

Mounting Plate

La platina permite conectar tanto las patas como las ruedas al perfil de aluminio y mejorar la terminación de la estructura.
The Mounting Plate is used to attach feet and castors to the profile and to improve the structure appearance.

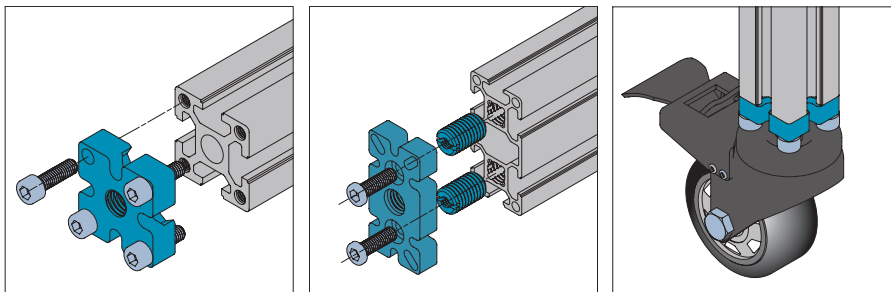

Material y color: Fundición de hierro con terminación en pintura gris / Die Cast Steel with powder coating grey





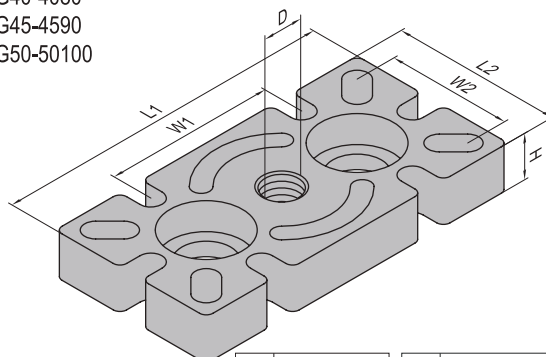
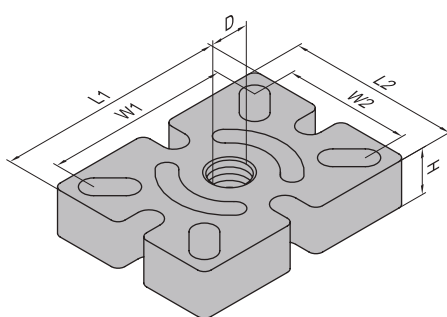
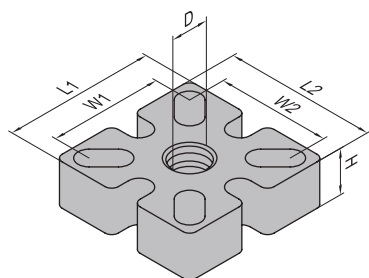

PG40-4040
 PG45-4545
 PG50-5050

PG40-4060
 PG45-4560

PG30-3060
 PG40-4080
 PG45-4590
 PG50-50100



FI	Fastening Set	FZ	Fastening Set
	M6x25 Bolt zinc plated		M6x20 Bolt zinc plated
	M10→M6 Hole Reducer Bolt nickel plated		M12→M6 Hole Reducer Bolt nickel plated

Aplicación	Descripción	D (mm)	Φ	L1 (mm)	L2 (mm)	W1 (mm)	W2 (mm)	Fastening Set	Masa (g)	Part No.
PG40-Profile 4040	PG40-4040	M12	40	40	30	30	12	4x(M6x20)	128	5.32.40.4040
PG45-Profile 4545	PG45-4545	M12	45	45	33	33		4xFI	203	5.32.45.4545
PG50-Profile 5050	PG50-5050	M12	50	50	35	35		4x(M8x20)	218	5.32.50.5050
PG40-Profile 4060	PG40-4060	M12	60	40	50	30		4x(M6x20)	176	5.32.40.4060
PG45-Profile 4560	PG45-4560	M12	60	45	48	33		4xFI	220	5.32.45.4560
PG30-Profile 3060	PG30-3060	M12	60	30	30		10	2xFZ	133	5.32.30.3060
PG40-Profile 4080	PG40-4080	M12	80	40	40	30	12	2x(M14x25)	272	5.32.40.4080.M12
		M16						2x(M14x25)	270	5.32.40.4080.M16
PG45-Profile 4590	PG45-4590	M12	90	45	45	33		2x(M14x25)	332	5.32.45.4590.M12
		M16						2x(M14x25)	330	5.32.45.4590.M16
PG50-Profile 50100	PG50-50100	M12	100	50	50	35		2x(M14x25)	332	5.32.50.50100.M12
		M16						2x(M14x25)	329	5.32.50.50100.M16
		M20						2x(M14x25)	327	5.32.50.50100.M20

Elementos de Apoyo

Floor Elements

Platina de Montaje

Mounting Plate



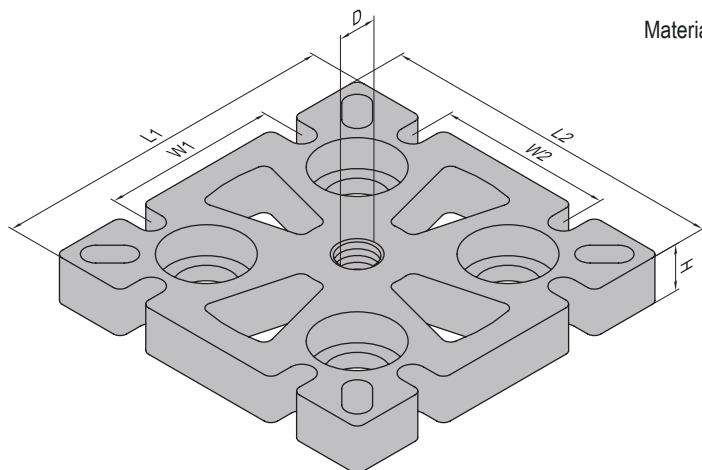
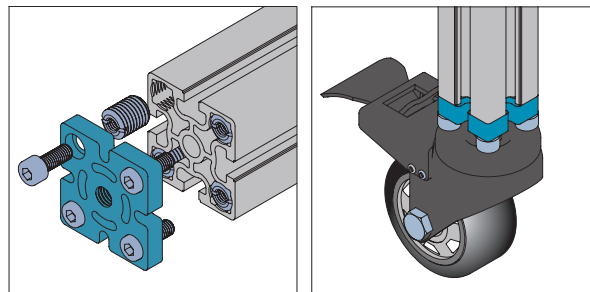

La platina permite conectar tanto las patas como las ruedas al perfil de aluminio y mejorar la terminación de la estructura.

Mounting Plate is used to attach feet and castors to the profile and to improve the structure appearance.



Material y color: Fundición de hierro con terminación en pintura gris
Die Cast Steel with powder coating grey



FY	Fastening Set	FZ	Fastening Set
	M6x20 Bolt zinc plated		M6x20 Bolt zinc plated
	M16-M8 Hole Reducer Bolt nickel plated		M12-M6 Hole Reducer Bolt nickel plated

Aplicación	Descripción	D (mm)	L1 (mm)	L2 (mm)	W1 (mm)	W2 (mm)	H (mm)	Fastening Set	Masa (g)	Part No.
PG30-Profile 6060	PG30-6060	M12	60	60	30	30	10	4xFZ	232	5.32.30.6060.M12
		M16							230	5.32.30.6060.M16
PG40-Profile 8080	PG40-8080	M12	80	80	40	40	12	4x(M14x25)	534	5.32.40.8080.M12
		M16						532	5.32.40.8080.M16	
		M20						530	5.32.40.8080.M20	
PG45-Profile 9090	PG45-9090	M12	90	90	45	45		4x(M14x25)	664	5.32.45.9090.M12
		M16						661	5.32.45.9090.M16	
		M20						659	5.32.45.9090.M20	
PG50-Profile 100100	PG50-100100	M12	100	100	50	50		4x(M14x25)	725	5.32.50.100100.M12
		M16						722	5.32.50.100100.M16	
		M20						720	5.32.50.100100.M20	
PG60-Profile 6060	PG60-6060	M12	60	60	40	40		4xFY	330	5.32.60.6060

Elementos de Apoyo

Floor Elements

Platina de Montaje
Mounting Plate

La platina permite conectar tanto las patas como las ruedas al perfil de aluminio y mejorar la terminación de la estructura.
Mounting Plate is used to attach feet and castors to the profile and to improve the structure appearance.

Material y color: Fundición de hierro con terminación en pintura gris
Die Cast Steel with powder coating grey

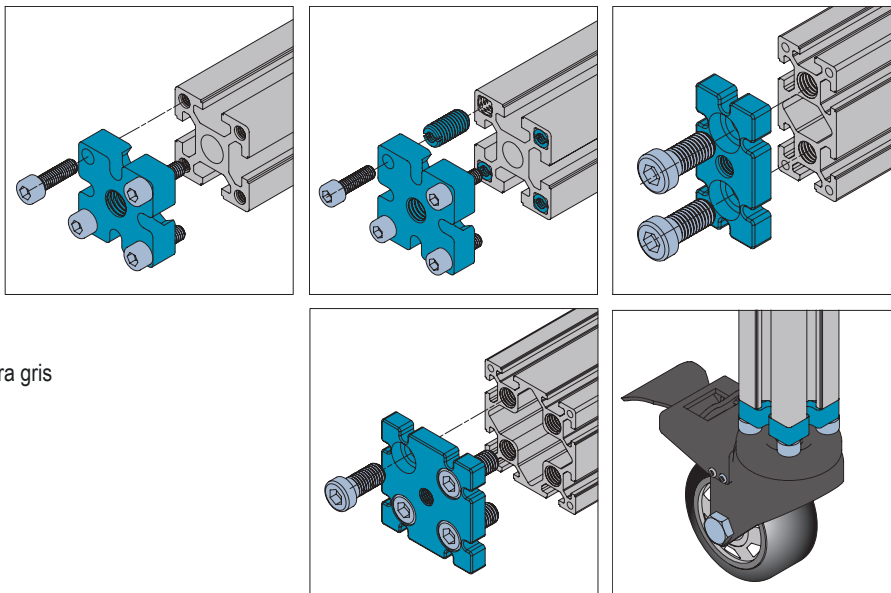

PG40-4040
PG45-4545

PG40-4080
PG45-4590

PG40-8080
PG45-9090

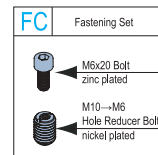
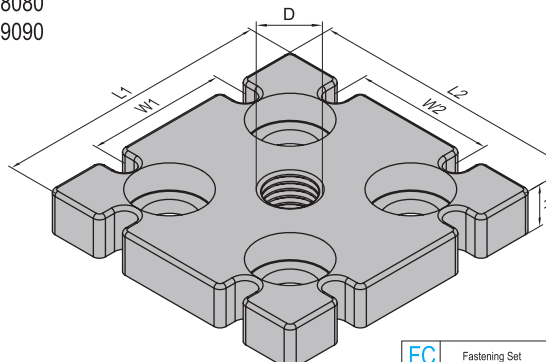
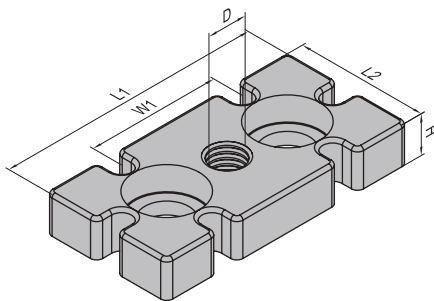
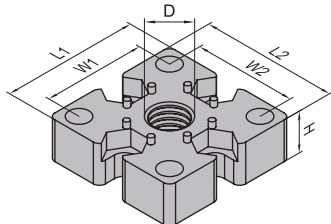

Aplicación	Descripción	D (mm)	Φ	L1 (mm)	L2 (mm)	W1 (mm)	W2 (mm)	Fastening Set	Masa (g)	Part No.
PG40-Profile 4040	PG40-4040	M12	40	40	30	30	12	4x(M6x20)	117	5.33.40.4040
PG45-Profile 4545	PG45-4545	M12	45	45	33	33		4xFC	189	5.33.45.4545
PG40-Profile 4080	PG40-4080	M12	80	40	40			2x(M14x25)	277	5.33.40.4080.M12
		M16						275	5.33.40.4080.M16	
PG45-Profile 4590	PG45-4590	M12	90	45	45			2x(M14x25)	344	5.33.45.4590.M12
		M16						342	5.33.45.4590.M16	
PG40-Profile 8080	PG40-8080	M12	80	80	40	40		4x(M14x25)	582	5.33.40.8080.M12
		M16						580	5.33.40.8080.M16	
		M20						577	5.33.40.8080.M20	
PG45-Profile 9090	PG45-9090	M12	90	90	45	45		4x(M14x25)	714	5.33.45.9090.M12
		M16						712	5.33.45.9090.M16	
		M20						709	5.33.45.9090.M20	

Elementos de Apoyo

Floor Elements

Platina para Rueda Giratoria Castor Wheel Plate

La Platina para Rueda Giratoria se utiliza para la conexión de las ruedas giratorias al lateral de los perfiles de aluminio.

Castor Plate is used to attached Castor-Plate-Heavy wheel to the aluminium profile structure.

Material: Fundición de hierro zincada / Zinc Plated Die Cast Steel

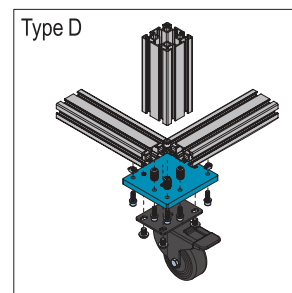
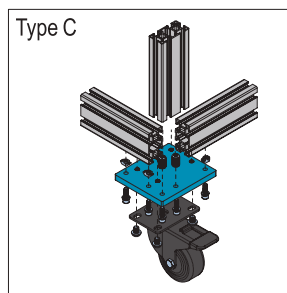
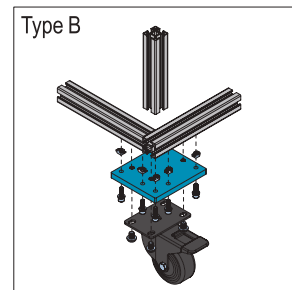
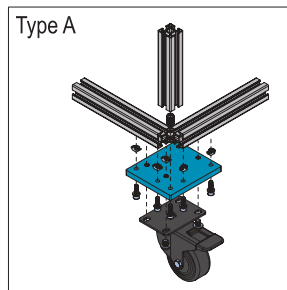
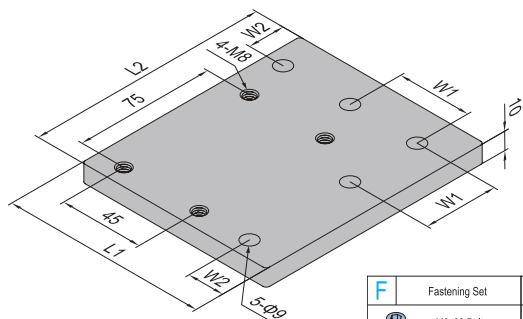

F	Fastening Set	J	Fastening Set	AB	Fastening Set	AC	Fastening Set	AD	Fastening Set	AE	Fastening Set	AF	Fastening Set
	M8x20 Bolt zinc plated		M8x25 Bolt zinc plated		M6x20 Bolt zinc plated		M6 Spring Washer zinc plated		M8x12 Bolt zinc plated		M8 Spring Washer zinc plated		M8 Washer zinc plated
	M8 Spring Washer zinc plated		M8 Washer zinc plated		M6 Washer zinc plated		M12-M6 Hole Reducer Bolt nickel plated		M8 Washer zinc plated		M14-M6 Hole Reducer Bolt nickel plated		M8 Washer zinc plated
	M8 Washer zinc plated		M8 T Nut nickel plated		M6 Washer zinc plated								M8 Washer zinc plated
	M8 T Nut nickel plated				M6 Washer zinc plated								M8 Washer zinc plated

Descripción	L1 (mm)	L2 (mm)	W1 (mm)	W2 (mm)	Fastening Set	Masa (g)	Part No.
PG30 -(set A)	105	120	30	15	4xAB+1xAC+4xAD	1056	5.34.30.STA
PG30 -(set B)	105	120	30	15	5xAB+4xAD	1049	5.34.30.STB
PG30 -(set C)	105	120	30	15	3xAB+2xAC+4xAD	1063	5.34.30.STC
PG30 -(set D)	105	120	30	15	2xAB+3xAC+4xAD	1070	5.34.30.STD
PG40 -(set A)	110	130	40	20	4xF+1xAE+4xAD	1229	5.34.40.STA
PG40 -(set B)	110	130	40	20	5xF+4xAD	1222	5.34.40.STB
PG40 -(set C)	110	130	40	20	3xF+2xAE+4xAD	1236	5.34.40.STC
PG40 -(set D)	110	130	40	20	2xF+3xAE+4xAD	1243	5.34.40.STD
PG45 -(set A)	120	130	45	22.5	4xJ+1xAF+4xAD	1237	5.34.45.STA
PG45 -(set B)	120	130	45	22.5	5xJ+4xAD	1230	5.34.45.STB
PG45 -(set C)	120	130	45	22.5	3xJ+2xAF+4xAD	1244	5.34.45.STC
PG45 -(set D)	120	130	45	22.5	2xJ+3xAF+4xAD	1251	5.34.45.STD

Elementos de Apoyo
Floor Elements

Platina para Rueda Giratoria
Castor Wheel Plate

La Platina para Rueda Giratoria se utiliza para la conexión de las ruedas giratorias al lateral de los perfiles de aluminio.
Castor Plate is used to attached Castor-Threaded wheel to the aluminium profile structure.

Material: Fundición de hierro zincada / Zinc Plated Die Cast Steel

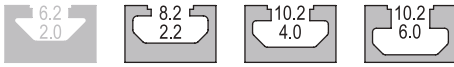
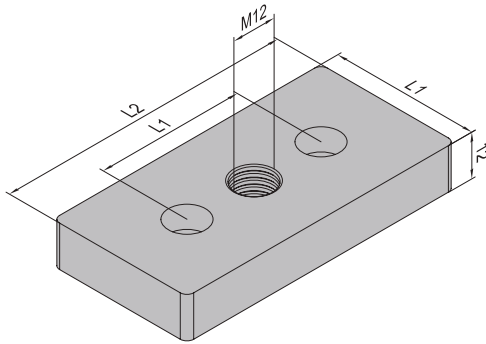
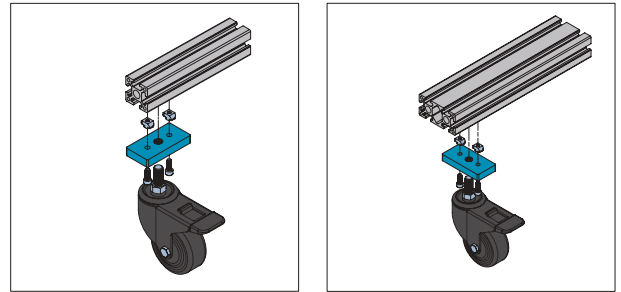

CP	Fastening Set	CQ	Fastening Set
	M6x12 Bolt zinc plated		M6x16 Bolt zinc plated
	M6 T Nut nickel plated		M6 T Nut nickel plated

Descripción	L1 (mm)	L2 (mm)	Fastening Set	Masa (g)	Part No.
PG30 -(set)	30	60	2xCP	162	5.35.30.ST
PG40 -(set)	40	80	2xCQ	296	5.35.40.ST
PG45 -(set)	45	90	2xCQ	377	5.35.45.ST

Nota / Note

Cuando la rueda giratoria se instala como indica la figura, se requiere maquinar el perfil de aluminio con un agujero D12,5mm y 20mm de profundidad.

When the castor is installed as the image below, the profiles needs to be machined with a D12,5mm and 20mm depth hole.

Elementos de Apoyo
Floor Elements

Rueda Giratoria
Castor Wheel

Material: Base-acero al carbono con pintura electroestática color negro / rueda-poliuretano
Base-Mild Steel with powder coating black / Wheel-polyurethane

Castor-Thread-Universal

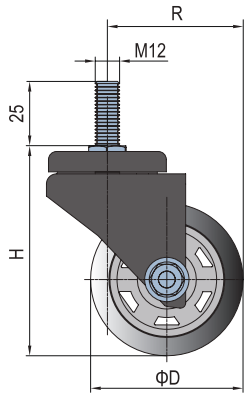

Castor-Thread-Brake

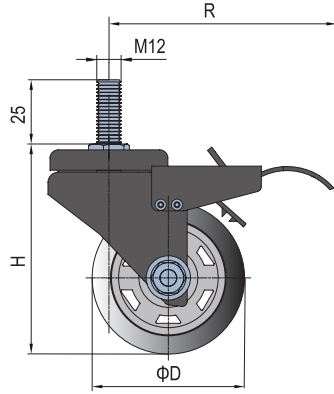

Castor-Plate-Universal

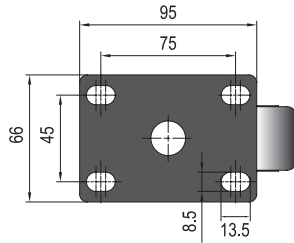
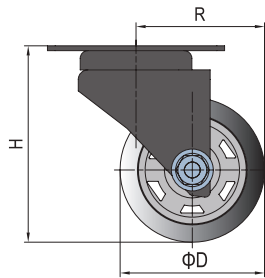

Castor-Plate-Fixed

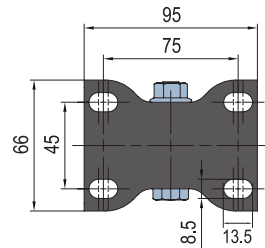
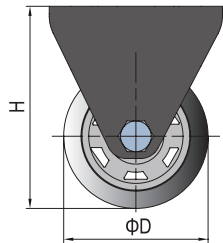

Castor-Plate-Brake

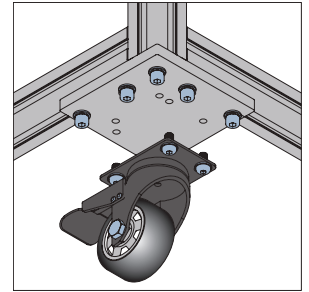
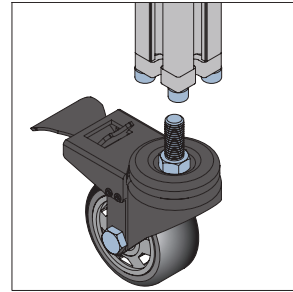
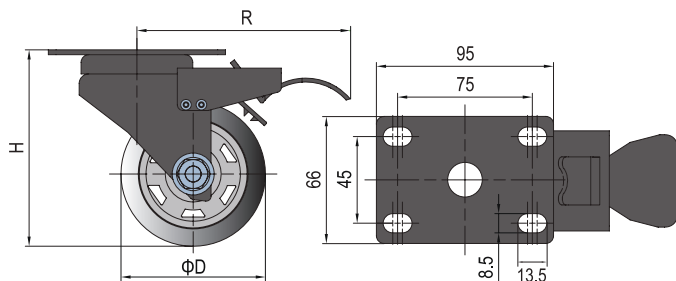

Castor-Plate-Universal-Heavy

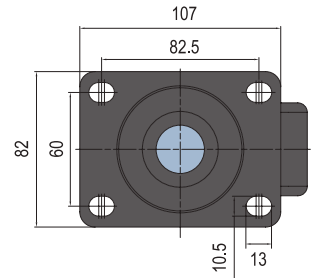
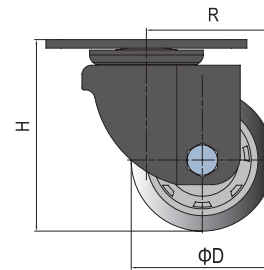

Castor-Plate-Fixed-Heavy

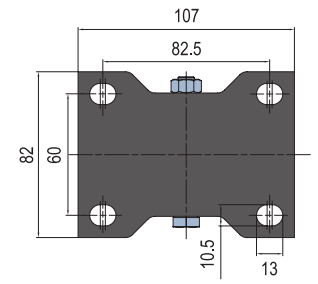
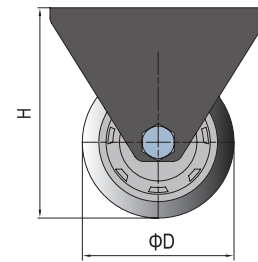

Descripción	D (mm)	R (mm)	H (mm)	Carga (N)	Masa (g)	Part No.
Castor-Thread-Universal	63	63	92	800	550	5.41.63.M12
	75	73	107	1050	670	5.41.75.M12
	100	87	130	1350	790	5.41.100.M12
Castor-Thread-Brake	63	103	92	800	650	5.41.63.M12B
	75	103	107	1050	770	5.41.75.M12B
	100	111	130	1350	930	5.41.100.M12B
Castor-Plate-Fixed	63		92	800	370	5.41.63F
	75		107	1050	490	5.41.75F
	100		130	1350	670	5.41.100F
Castor-Plate-Universal	63	63	92	800	570	5.41.63U
	75	73	107	1050	690	5.41.75U
	100	87	130	1350	870	5.41.100U
Castor-Plate-Brake	63	103	92	800	670	5.41.63B
	75	103	107	1050	790	5.41.75B
	100	111	130	1350	970	5.41.100B
Castor-Plate-Universal-Heavy	75	65	104	6000	1150	5.41.75UH
Castor-Plate-Fixed-Heavy	75		104	6000	950	5.41.75FH

Elementos de Apoyo

Floor Elements

Base de Refuerzo

Base Angle

La Base de Refuerzo permite mejorar la estabilidad de la estructura que apoya sobre patas de nivelación.

The Base Angle improves the stability of the structure when leveling feet are used.

Material: Acero al carbono, tratamiento superficial de electrofóresis color negro

Mild Steel with powder coating black

Base Angle-Left/Right

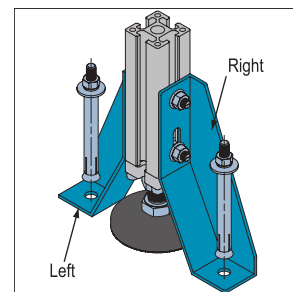
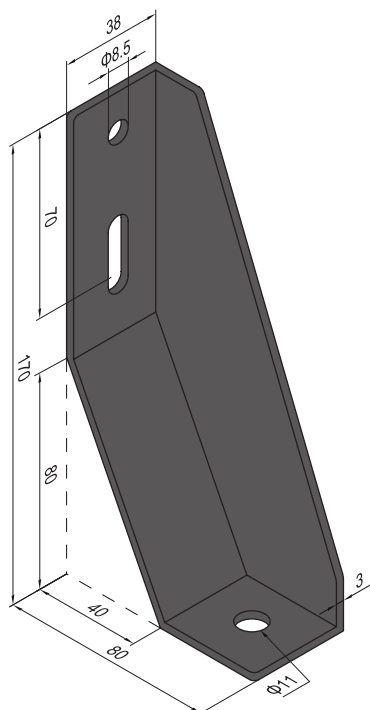

C	Fastening Set	AA	Fastening Set
	M8 Flange Nut zinc plated		M8x100 expansion bolt zinc plated
	M8x20 T Bolt nickel plated		

Descripción	Fastening Set	Masa (g)	Part No.
Base Angle-Left (pcs)		346	5.51.L
Base Angle-Left (set)	2xC+1xAA	443	5.51.L.ST
Base Angle-Right (pcs)		346	5.51.R
Base Angle-Right (set)	2xC+1xAA	443	5.51.R.ST
Base Angle-L+R (pair)		692	5.51.P
Base Angle-L+R (set)	4xC+2xAA	886	5.51.P.ST

Elementos de Apoyo
Floor Elements

Base con Pata y Rueda Giratoria
Foot and Caster Components

Material: Base-Acero al carbono con pintura color gris / Rueda-poliuretano
Base-Mild Steel with powder coating grey / Wheel-polyurethane

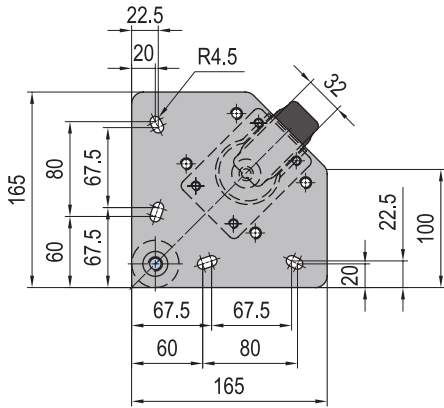
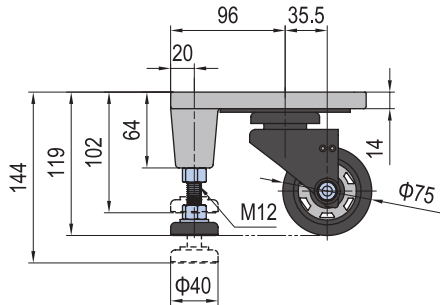

Wheel-PA Foot-zinc plated steel

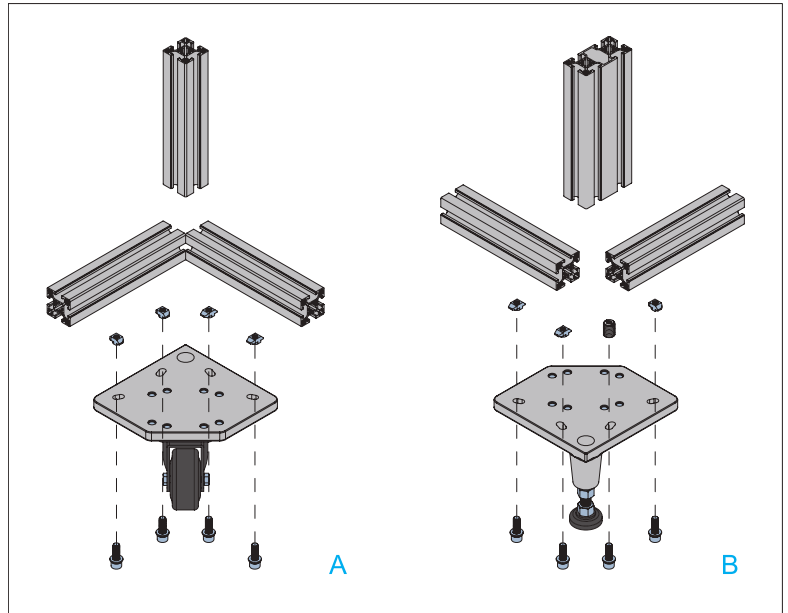
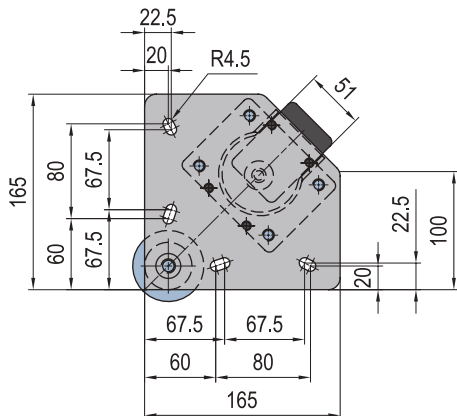
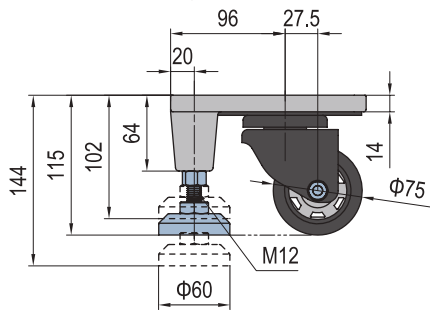

AF	Fastening Set	AG	Fastening Set	J	Fastening Set	W	Fastening Set
	M8x25 Bolt zinc plated		M8x30 Bolt zinc plated		M8x25 Bolt zinc plated		M8x30 Bolt zinc plated
	M8 Spring Washer zinc plated		M8 Spring Washer zinc plated		M8 Spring Washer zinc plated		M8 Spring Washer zinc plated
	M8 Washer zinc plated		M8 Washer zinc plated		M8 Washer zinc plated		M8 Washer zinc plated
	M14-M8 Hole Reducer Bolt nickel plated		M14-M8 Hole Reducer Bolt nickel plated		M8 T Nut nickel plated		M8 T Nut nickel plated

Descripción	Fastening Set	Carga (N)	Masa (g)	Part No.
Light-Weight		1050	3900	5.61.L
	4xJ	1050	3950	5.61.40.L.STA
	3xJ+1xAF	1050	3950	5.61.40.L.STB
	4xW	1050	3950	5.61.45.L.STA
Heavy-Weight		6000	4600	5.61.H
	4xJ	6000	4650	5.61.40.H.STA
	3xJ+1xAF	6000	4650	5.61.40.H.STB
	4xW	6000	4650	5.61.45.H.STA
	3xW+1xAG	6000	4650	5.61.45.H.STB



6.11-6.41

Perfil Reductor de Ranura T
T Slot Reducing Profile

Bloque para Montaje de Panel
Panel Mounting Block

Burlete para Montaje de Panel
Panel Mounting Strip

Bloque para Montaje de Malla
Mounting Block

6

Elementos para Instalación de Paneles *Panel Installation Elements*

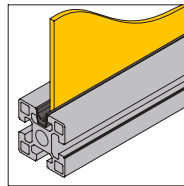

6.11.01

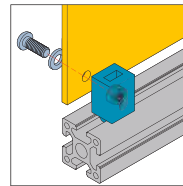

6.21.01

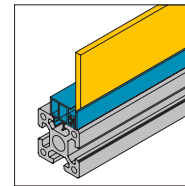

6.31.01

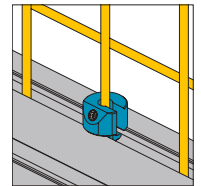

6.41.01

Elementos para Instalación de Paneles

Panel Installation Elements

Perfil Reductor de Ranura T
T Slot Reducing Profile

El Perfil Reductor de Ranura T se utiliza para reducir el ancho de la ranura y permitir la instalación de paneles de menor espesor.
T Slot Reducing Profile is used to reduce the slot width and allow thin panel to be installed.

Material y color: PVC negro / black

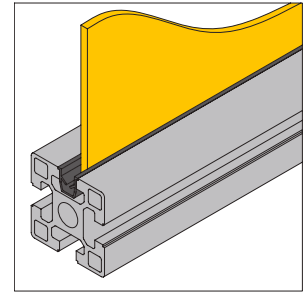

T Slot Reducing Profile-8

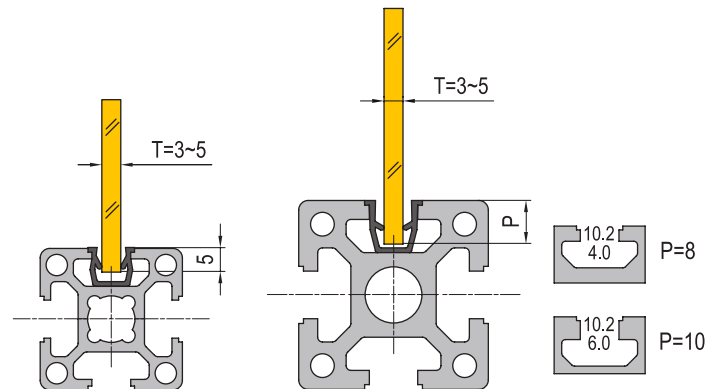
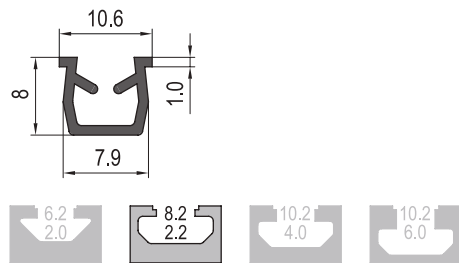

T Slot Reducing Profile-10

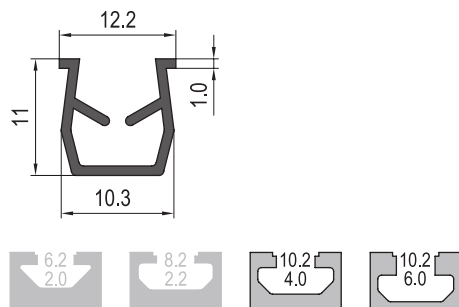

Descripción	Masa (g/m)	Largo	Part No.
T Slot Reducing Profile-8	51	2000mm/bar	6.11.08
T Slot Reducing Profile-10	64	2000mm/bar	6.11.10

Elementos para Instalación de Paneles
Panel Installation Elements

Bloque para Montaje de Panel
Panel Mounting Plate

El Bloque para Montaje de Panel permite conectar el perfil de aluminio a paneles de diferente material y espesor.
The Block is used to attach various thickness and material panels to the profile.

Material y color: Bloque-PVC negro / Block-PCV black
Panel Mounting Block-6

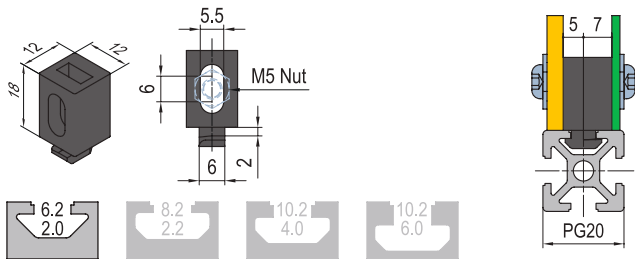

Panel Mounting Block-8

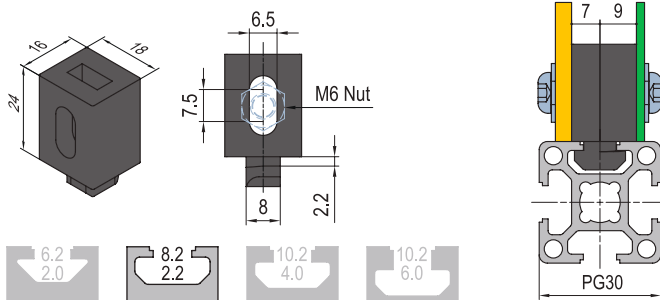

Panel Mounting Block-10-4

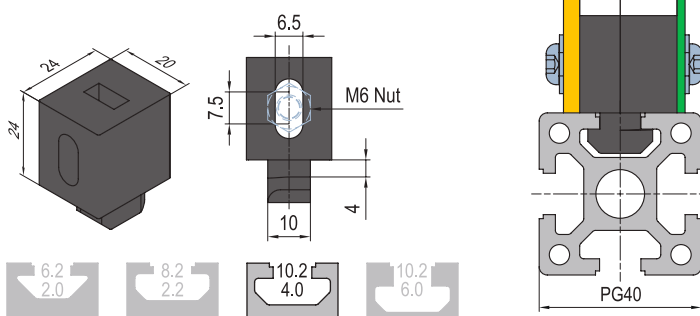

Panel Mounting Block-10-6

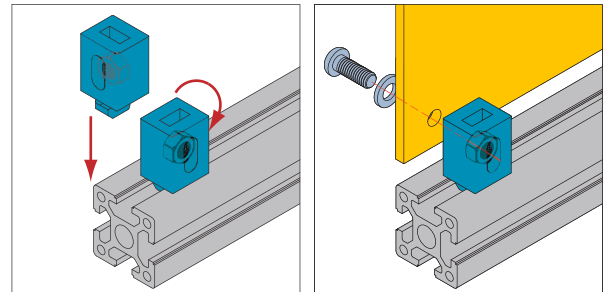
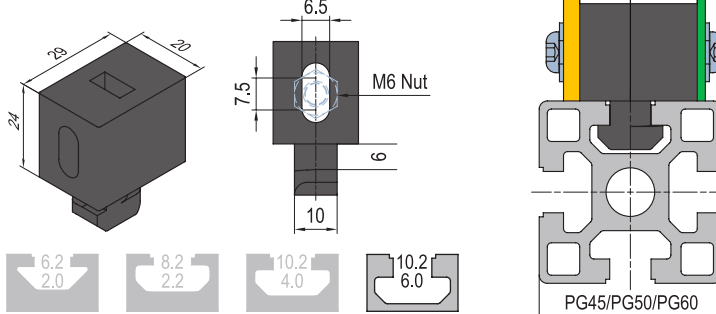

FM	Fastening Set	FN	Fastening Set	FP	Fastening Set
	M5x14 Bolt zinc plated		M6x16 Bolt zinc plated		M6x25 Bolt zinc plated
	M5 Washer zinc plated		M6 Washer zinc plated		M6 Washer zinc plated

Descripción	Fastening Set	Masa (g)	Part No.
Panel Mounting Block-6 (pcs)		4.4	6.21.06
Panel Mounting Block-6 (set)	1xFM	7	6.21.06.ST
Panel Mounting Block-8 (pcs)		9	6.21.08
Panel Mounting Block-8 (set)	1xFN	13.5	6.21.08.ST
Panel Mounting Block-10-4 (pcs)		15.8	6.21.10.04
Panel Mounting Block-10-4 (set)	1xFP	23.8	6.21.10.04.ST
Panel Mounting Block-10-6 (pcs)		20	6.21.10.06
Panel Mounting Block-10-6 (set)	1xFP	29	6.21.10.06.ST

Elementos para Instalación de Paneles

Panel Installation Elements

Burlete para Montaje de Panel
Panel Mounting Strip

El Burlete para Montaje de Panel es usado extensamente como solución de cerramientos en salas blancas.
Panel Mounting Strip is used to attach 3 and 5mm thickness panels to the profile as a solution for clean room systems.

Material y color: Bloque-PVC gris / *Block-PVC grey*

Panel Mounting Strip-8-5

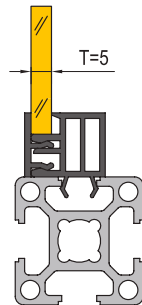
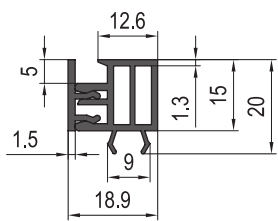

Panel Mounting Strip-10-4-3

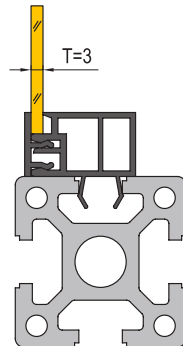
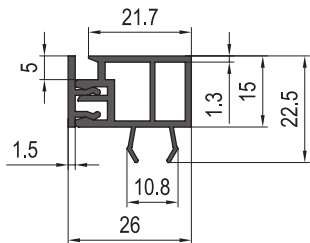

Panel Mounting Strip-10-4-5

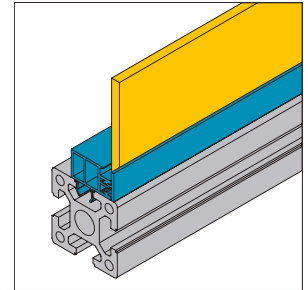
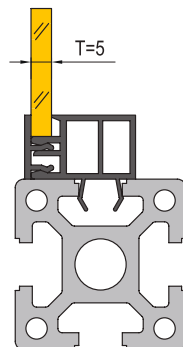
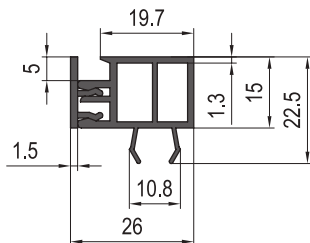

Descripción	Masa (g/m)	Largo	Part No.
Panel Mounting Strip-8-5	220	2000mm/bar	6.31.08.02
Panel Mounting Strip-10-4-3	273	2000mm/bar	6.31.10.04.01
Panel Mounting Strip-10-4-5	260	2000mm/bar	6.31.10.04.02

Elementos para Instalación de Paneles *Panel Installation Elements*

Bloque para Montaje de Malla
Mounting Block

El Bloque para Montaje de Malla es usado para fijar mallas de espesor 4mm a un marco de perfiles de aluminio estándar.
Mounting Block is used to attach the 4mm thickness mesh to an aluminium profile frame.

Material: Fundición de zinc / *Die Cast Zinc*

Mounting Block-8

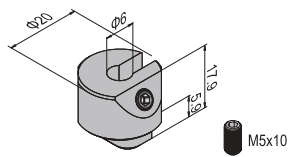

Mounting Block-10

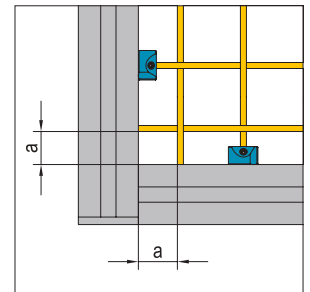
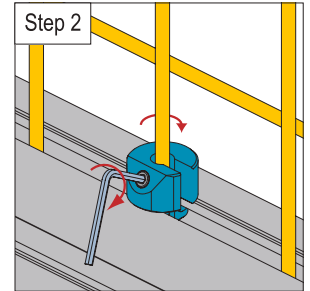
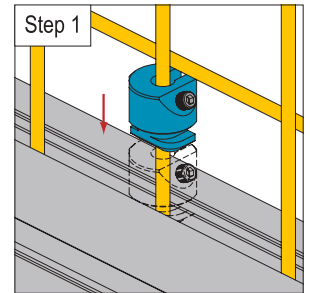
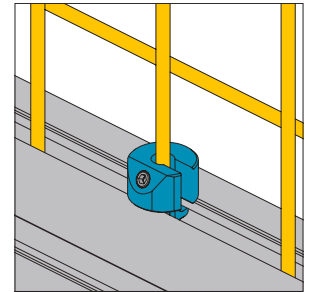
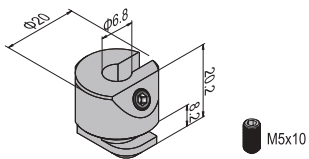

Nota / Note

- La distancia (a) entre el perfil y la malla debe ser mayor que 20mm.
- La distancia óptima entre bloques de montaje es 300mm.
- *Distance (a) between the profile and the mesh should be more than 20mm.*
- *The recommended distance between two blocks is 300mm.*

Descripción	Masa (g/pcs)	Part No.
Mounting Block-8(with top thread)	20	6.41.08.01
Mounting Block-10(with top thread)	22	6.41.10.01



7.11-7.51

Manija / Asa
Handle

Bisagra
Hinge

Cerradura
Lock

Cierre Magnético
Magnet Catch

Cerradura de Puerta
Door Locks

Perfil para Ventana Corrediza
Sliding Door Profile

7

Elementos de Puertas y Ventanas Door and Window Elements

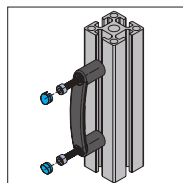

7.11-13

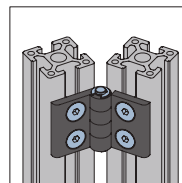

7.21-28

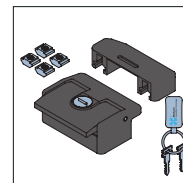

7.31.01

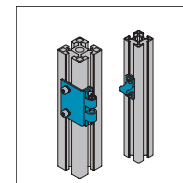

7.41

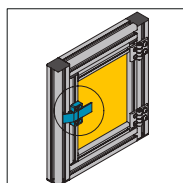

7.42.01

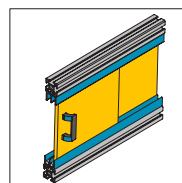

7.51.01







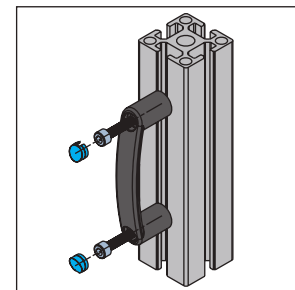
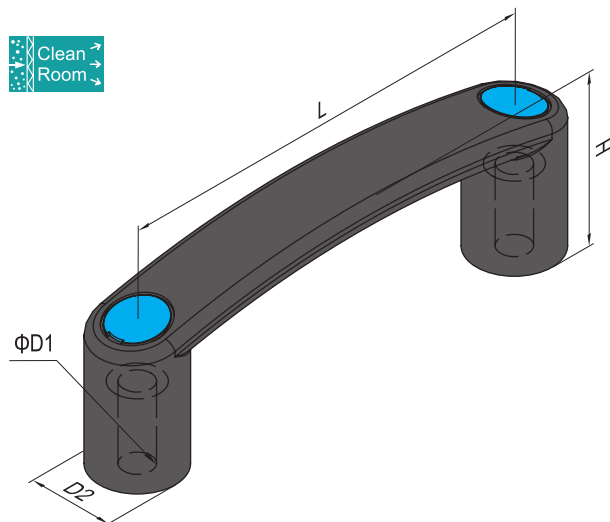

Elementos de Puertas y Ventanas

























Door and Window Elements

 Manija / Asa
 Handle

Material y color: Manija-PA6 negro con tapones azules o negros / Handle-PA6 black with blue or black buttons



CA	Fastening Set	CB	Fastening Set	CD	Fastening Set	CE	Fastening Set
	M5x25 Bolt zinc plated		M6x25 Bolt zinc plated		M8x25 Bolt zinc plated		M8x30 Bolt zinc plated
	M5 T Nut nickel plated		M6 T Nut nickel plated		M8 T Nut nickel plated		M8 T Nut nickel plated

Aplicación	Descripción	L (mm)	H (mm)	D1 (mm)	D2 (mm)	Fastening Set	Color de Tapa	Masa (g)	Part No.	
PG15/20 	PA6 Handle-90 (pcs)	90	36	6.5	18			23	7.11.90.06.BE	
	PA6 Handle-90 (set)					2xCA		41	7.11.90.06.BE.ST	
	PA6 Handle-90 (pcs)							23	7.11.90.06.BK	
	PA6 Handle-90 (set)					2xCA		41	7.11.90.06.BK.ST	
PG30 	PA6 Handle-90 (pcs)	90	36	6.5	18			23	7.11.90.08.BE	
	PA6 Handle-90 (set)					2xCB		45	7.11.90.08.BE.ST	
	PA6 Handle-90 (pcs)							23	7.11.90.08.BK	
	PA6 Handle-90 (set)					2xCB		45	7.11.90.08.BK.ST	
	PG40 	PA6 Handle-120 (pcs)	120	40	8.5	25			45	7.11.120.08.BE
		PA6 Handle-120 (set)					2xCB		68	7.11.120.08.BE.ST
		PA6 Handle-120 (pcs)							45	7.11.120.08.BK
		PA6 Handle-120 (set)					2xCB		68	7.11.120.08.BK.ST
PG45/50/60 	PA6 Handle-120 (pcs)	120	40	8.5	25			45	7.11.120.10.04.BE	
	PA6 Handle-120 (set)					2xCD		88	7.11.120.10.04.BE.ST	
	PA6 Handle-120 (pcs)							45	7.11.120.10.04.BK	
	PA6 Handle-120 (set)					2xCD		88	7.11.120.10.04.BK.ST	
PG45/50/60 	PA6 Handle-120 (pcs)	120	40	8.5	25			45	7.11.120.10.06.BE	
	PA6 Handle-120 (set)					2xCE		104	7.11.120.10.06.BE.ST	
	PA6 Handle-120 (pcs)							45	7.11.120.10.06.BK	
	PA6 Handle-120 (set)					2xCE		104	7.11.120.10.06.BK.ST	

Elementos de Puertas y Ventanas

Door and Window Elements

Manija / Asa
Handle

Material y color: Manija-PA6 negro con tapones azules o negros / Handle-PA6 black with blue or black buttons

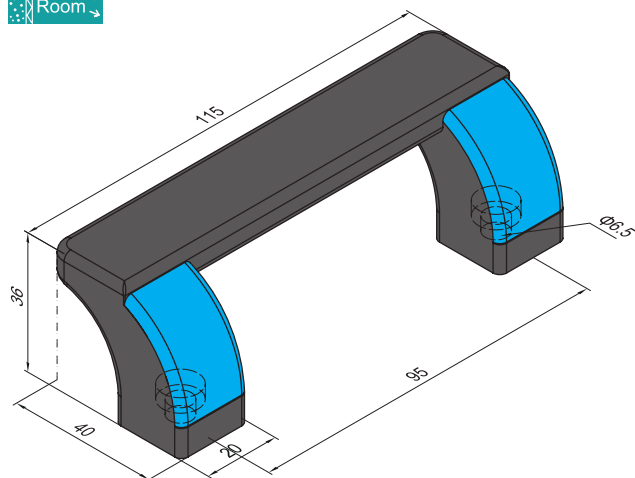
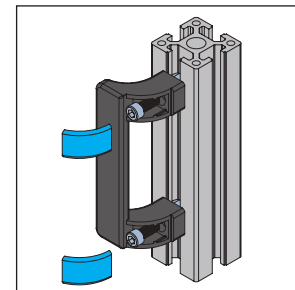

CP	Fastening Set	CQ	Fastening Set
	M6x12 Bolt zinc plated		M6x16 Bolt zinc plated
	M6 T Nut nickel plated		M6 T Nut nickel plated

Aplicación	Descripción	Fastening Set	Color de Tapa	Masa (g)	Part No.
PG30 	Guard Wing Handle -95 (pc)			70	7.12.95.08.BE
	Guard Wing Handle -95 (set)	2xCP		88	7.12.95.08.BE.ST
	Guard Wing Handle -95 (pc)			70	7.12.95.08.BK
	Guard Wing Handle -95 (set)	2xCP		88	7.12.95.08.BK.ST
PG40/45/50/60 	Guard Wing Handle -95 (pc)			70	7.12.95.10.BE
	Guard Wing Handle -95 (set)	2xCQ		96	7.12.95.10.BE.ST
	Guard Wing Handle -95 (pc)			70	7.12.95.10.BK
	Guard Wing Handle -95 (set)	2xCQ		96	7.12.95.10.BK.ST

Elementos de Puertas y Ventanas
Door and Window Elements

Manija / Asa de Aluminio
Aluminum Handle

Material y color: Manija-aluminio / tapa-ABS gris o negro
Handle-aluminium / Cap-ABS grey or black

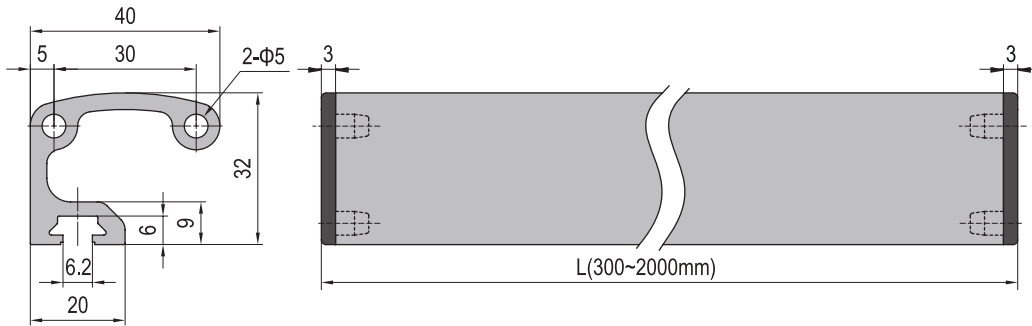
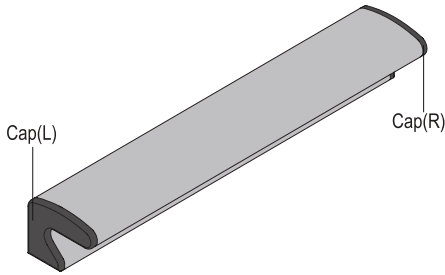
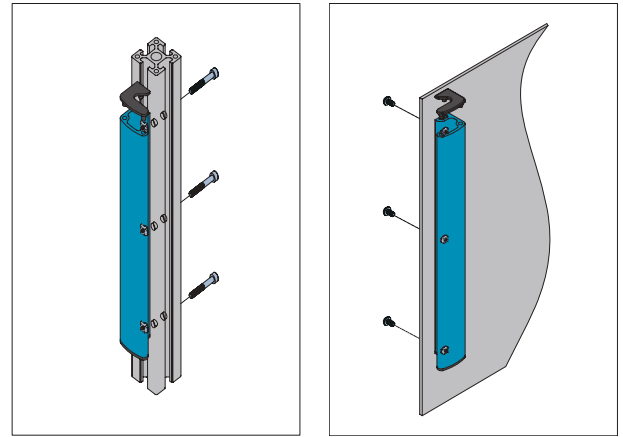

PA	Fastening Set	PB	Fastening Set
	M5x10 Bolt zinc plated		M5x3S Bolt zinc plated
	M5 Washer zinc plated		M5 T Nut nickel plated

Aplicación	Descripción	Color de Tapa	L (mm)	Fastening Set	Masa (g)	Part No.	
4mm Panel	Aluminum Handle (pc)		300		216	7.13.P.GY	
	Aluminum Handle (set)			3×PA	224	7.13.P.GY.ST	
	Aluminum Handle (pc)				216	7.13.P.BK	
	Aluminum Handle (set)			3×PA	224	7.13.P.BK.ST	
PG40/45	Aluminum Handle (pc)					216	7.13.10.GY
	Aluminum Handle (set)			3×PB	231	7.13.10.GY.ST	
	Aluminum Handle (pc)					216	7.13.10.BK
	Aluminum Handle (set)			3×PB	231	7.13.10.BK.ST	

Nota: El largo puede ser personalizado de acuerdo al requerimiento del cliente de 300 ~ 2000mm.
Ejemplo: 7.13.P.GY - 500

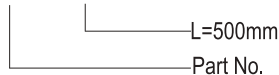

Elementos de Puertas y Ventanas

Door and Window Elements





Bisagra

Hinge

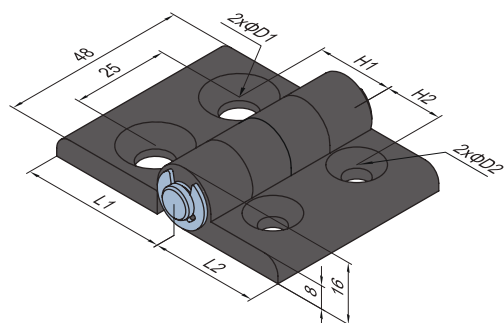
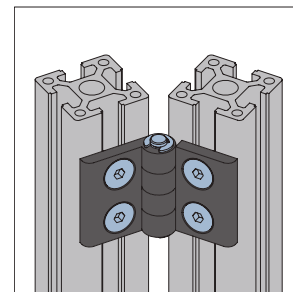
Material y color: PA6 negro / black

Hinge-PA6



FG	Fastening Set	FL	Fastening Set
	M5x16 Bolt zinc plated		M6x14 Bolt zinc plated
	M5 T Nut nickel plated		M6 T Nut nickel plated

Descripción	H1 (mm)	H2 (mm)	L1 (mm)	L2 (mm)	D1 (mm)	D2 (mm)	Fastening Set	Masa (g)	Part No.
30/30 (pcs)	15	15	28	28	6.5	6.5		39	7.21.30.30
30/30 (set)	15	15	28	28	6.5	6.5	4xFL	73	7.21.30.30.ST
30/40 (pcs)	20	15	38	28	8.5	6.5		42	7.21.30.40
30/40 (set)	20	15	38	28	8.5	6.5	2xFG+2xFL	88	7.21.30.40.ST
40/40 (pcs)	20	20	38	38	8.5	8.5		45	7.21.40.40
40/40 (set)	20	20	38	38	8.5	8.5	4xFG	108	7.21.40.40.ST

Elementos de Puertas y Ventanas
Door and Window Elements

Bisagra
Hinge

Material y color: Aluminio anodizado gris / Anodized aluminium grey

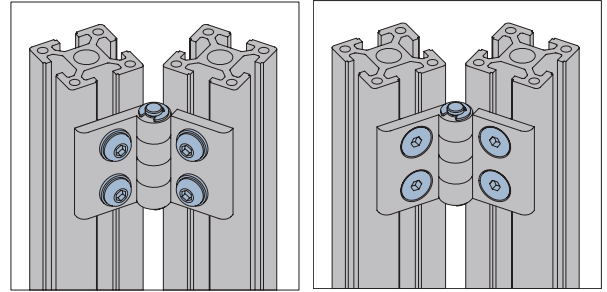

Hinge-Aluminum Countersink Hole

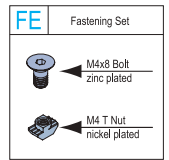
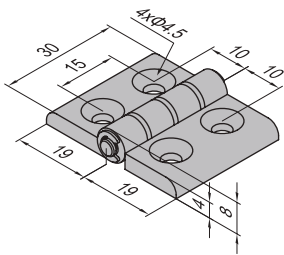

Descripción	H1 (mm)	H2 (mm)	L1 (mm)	L2 (mm)	D1 (mm)	D2 (mm)	Fastening Set	Masa (g)	Part No.
20/20 (pcs)								15	7.22.20.20
20/20 (set)							4xFE	25	7.22.20.20.ST

Hinge-Aluminum Countersink Hole

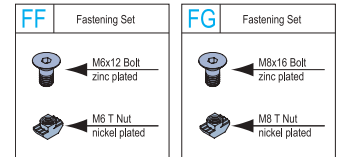
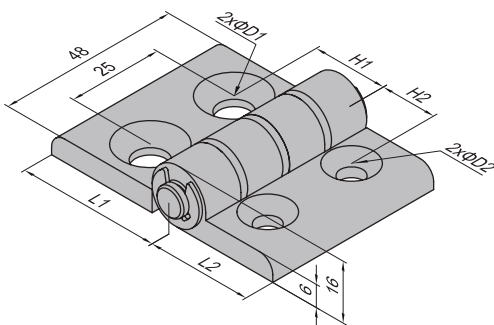

Descripción	H1 (mm)	H2 (mm)	L1 (mm)	L2 (mm)	D1 (mm)	D2 (mm)	Fastening Set	Masa (g)	Part No.
30/30 (pcs)	15	15	28	28	6.5	6.5		69	7.22.30.30
30/30 (set)	15	15	28	28	6.5	6.5	4xFF	97	7.22.30.30.ST
30/40 (pcs)	20	15	38	28	8.5	6.5		74	7.22.30.40
30/40 (set)	20	15	38	28	8.5	6.5	2xFF+2xFG	122	7.22.30.40.ST
30/45 (pcs)	22.5	15	38	28	8.5	6.5		74	7.22.30.45
30/45 (set)	22.5	15	38	28	8.5	6.5	2xFF+2xFG	122	7.22.30.45.ST
40/40 (pcs)	20	20	38	38	8.5	8.5		81	7.22.40.40
40/40 (set)	20	20	38	38	8.5	8.5	4xFG	149	7.22.40.40.ST
40/45 (pcs)	22.5	20	38	38	8.5	8.5		81	7.22.40.45
40/45 (set)	22.5	20	38	38	8.5	8.5	4xFG	149	7.22.40.45.ST
45/45 (pcs)	22.5	22.5	38	38	8.5	8.5		81	7.22.45.45
45/45 (set)	22.5	22.5	38	38	8.5	8.5	4xFG	149	7.22.45.45.ST

Elementos de Puertas y Ventanas

Door and Window Elements

Bisagra
Hinge

Material y color: Aluminio anodizado gris / Anodized aluminium grey



Hinge-Aluminum alloy-Through Hole

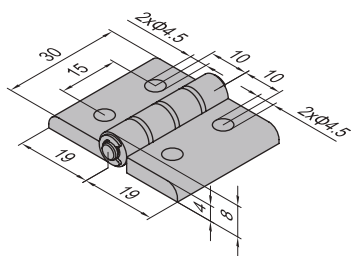

Hinge-Aluminum alloy-Through Hole

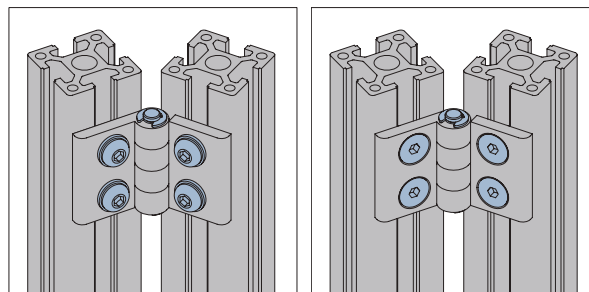
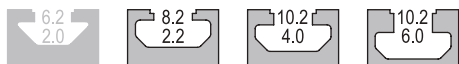
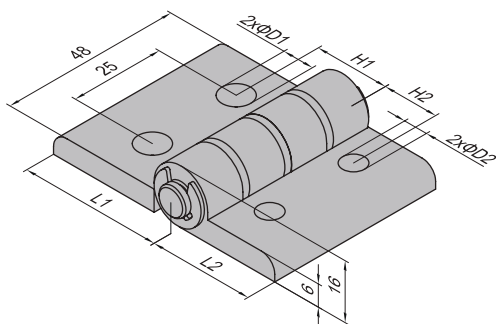

PC	Fastening Set
	M4x10 Bolt zinc plated
	M4 Washer zinc plated
	M4 T Nut nickel plated

Descripción	H1 (mm)	H2 (mm)	L1 (mm)	L2 (mm)	D1 (mm)	D2 (mm)	Fastening Set	Masa (g)	Part No.
20/20 (pcs)								15	7.23.20.20
20/20 (set)							4xPC	29	7.23.20.20.ST

FH	Fastening Set
	M6x14 Bolt zinc plated
	M6 Washer zinc plated
	M6 T Nut nickel plated

FJ	Fastening Set
	M8x16 Bolt zinc plated
	M8 Washer zinc plated
	M8 T Nut nickel plated

FK	Fastening Set
	M8x20 Bolt zinc plated
	M8 Washer zinc plated
	M8 T Nut nickel plated

Descripción	H1 (mm)	H2 (mm)	L1 (mm)	L2 (mm)	D1 (mm)	D2 (mm)	Fastening Set	Masa (g)	Part No.
30/30 (pcs)	15	15	28	28	6.5	6.5		71	7.23.30.30
30/30 (set)	15	15	28	28	6.5	6.5	4xFH	99	7.23.30.30.ST
30/40 (pcs)	20	15	38	28	8.5	6.5		76	7.23.30.40
30/40 (set)	20	15	38	28	8.5	6.5	2xFH+2xFJ	124	7.23.30.40.ST
30/45 (pcs)	22.5	15	38	28	8.5	6.5		76	7.23.30.45
30/45 (set)	22.5	15	38	28	8.5	6.5	2xFH+2xFK	127	7.23.30.45.ST
40/40 (pcs)	20	20	38	38	8.5	8.5		83	7.23.40.40
40/40 (set)	20	20	38	38	8.5	8.5	4xFJ	151	7.23.40.40.ST
40/45 (pcs)	22.5	20	38	38	8.5	8.5		83	7.23.40.45
40/45 (set)	22.5	20	38	38	8.5	8.5	2xFJ+2xFK	156	7.23.40.45.ST
45/45 (pcs)	22.5	22.5	38	38	8.5	8.5		83	7.23.45.45
45/45 (set)	22.5	22.5	38	38	8.5	8.5	4xFK	161	7.23.45.45.ST

Elementos de Puertas y Ventanas

Door and Window Elements

Bisagra
Hinge

Material y color: Aluminio anodizado gris / Anodized aluminium grey

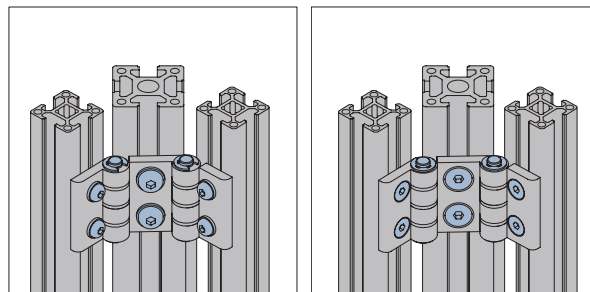

Hinge-Aluminum Countersink Hole

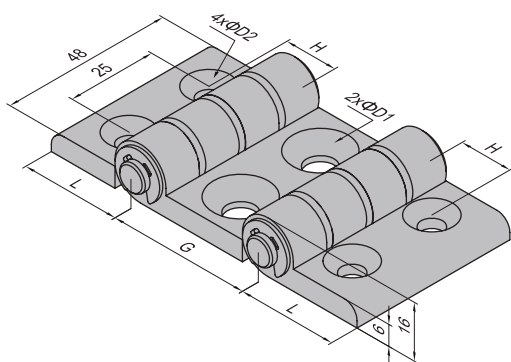

Descripción	G (mm)	H (mm)	L (mm)	D1 (mm)	D2 (mm)	Fastening Set	Masa (g)	Part No.
30/30/30 (pcs)	30	15	28	6.5	6.5		98	7.24.30.30.30
30/30/30 (set)	30	15	28	6.5	6.5	6xFF	140	7.24.30.30.30.ST
30/40/30 (pcs)	40	15	28	8.5	6.5		104	7.24.30.40.30
30/40/30 (set)	40	15	28	8.5	6.5	4xFF+2xFG	166	7.24.30.40.30.ST
30/45/30 (pcs)	45	15	28	8.5	6.5		108	7.24.30.45.30
30/45/30 (set)	45	15	28	8.5	6.5	4xFF+2xFG	170	7.24.30.45.30.ST
40/40/40 (pcs)	40	20	38	8.5	8.5		115	7.24.40.40.40
40/40/40 (set)	40	20	38	8.5	8.5	6xFG	217	7.24.40.40.40.ST
40/45/40 (pcs)	45	20	38	8.5	8.5		119	7.24.40.45.40
40/45/40 (set)	45	20	38	8.5	8.5	6xFG	221	7.24.40.45.40.ST
45/45/45 (pcs)	45	22.5	38	8.5	8.5		119	7.24.45.45.45
45/45/45 (set)	45	22.5	38	8.5	8.5	6xFG	221	7.24.45.45.45.ST

FF	FG	FH	FJ	FK
Fastening Set	Fastening Set	Fastening Set	Fastening Set	Fastening Set

Hinge-Aluminum Through Hole

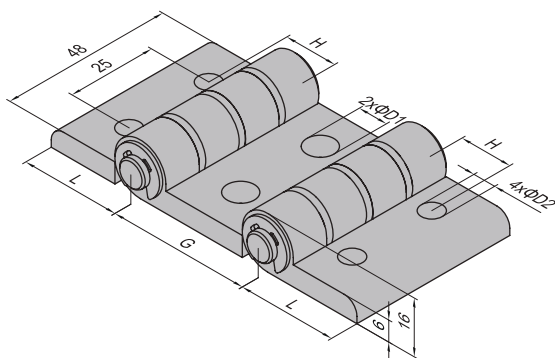

Descripción	G (mm)	H (mm)	L (mm)	D1 (mm)	D2 (mm)	Fastening Set	Masa (g)	Part No.
30/30/30 (pcs)	30	15	28	6.5	6.5		100	7.25.30.30.30
30/30/30 (set)	30	15	28	6.5	6.5	6xFH	142	7.25.30.30.30.ST
30/40/30 (pcs)	40	15	28	8.5	6.5		107	7.25.30.40.30
30/40/30 (set)	40	15	28	8.5	6.5	4xFH+2xFJ	169	7.25.30.40.30.ST
30/45/30 (pcs)	45	15	28	8.5	6.5		111	7.25.30.45.30
30/45/30 (set)	45	15	28	8.5	6.5	4xFH+2xFK	175	7.25.30.45.30.ST
40/40/40 (pcs)	40	20	38	8.5	8.5		121	7.25.40.40.40
40/40/40 (set)	40	20	38	8.5	8.5	6xFJ	213	7.25.40.40.40.ST
40/45/40 (pcs)	45	20	38	8.5	8.5		125	7.25.40.45.40
40/45/40 (set)	45	20	38	8.5	8.5	4xFJ+2xFK	230	7.25.40.45.40.ST
45/45/45 (pcs)	45	22.5	38	8.5	8.5		125	7.25.45.45.45
45/45/45 (set)	45	22.5	38	8.5	8.5	6xFK	245	7.25.45.45.45.ST

Elementos de Puertas y Ventanas

Door and Window Elements

Bisagra
Hinge

Material y color: Aluminio anodizado gris / Anodized aluminium grey

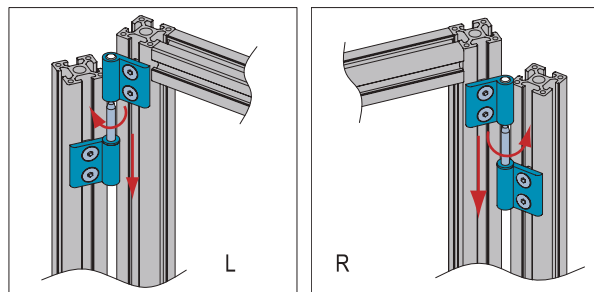

Al Removable Hinge-L

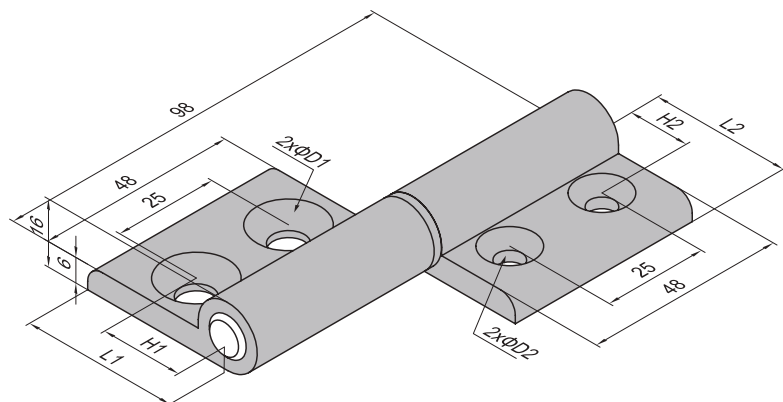

Al Removable Hinge-R

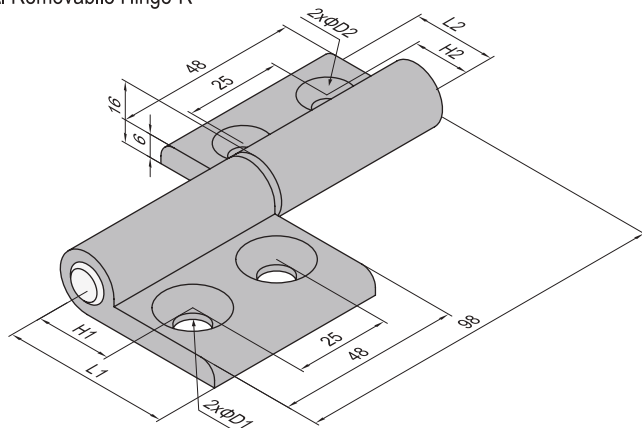

FF	Fastening Set	FG	Fastening Set
	M6x12 Bolt zinc plated		M8x16 Bolt zinc plated
	M6 T Nut nickel plated		M8 T Nut nickel plated

Descripción	H1 (mm)	H2 (mm)	L1 (mm)	L2 (mm)	D1 (mm)	D2 (mm)	Fastening Set	Masa (g)	Part No. (L)	Part No. (R)
30/30 (pcs)	15	15	28	28	6.5	6.5		105	7.26.30.30	7.27.30.30
30/30 (set)	15	15	28	28	6.5	6.5	4xFF	133	7.26.30.30.ST	7.27.30.30.ST
30/40 (pcs)	20	15	38	28	8.5	6.5		110	7.26.30.40	7.27.30.40
30/40 (set)	20	15	38	28	8.5	6.5	2xFF+2xFG	158	7.26.30.40.ST	7.27.30.40.ST
30/45 (pcs)	22.5	15	38	28	8.5	6.5		110	7.26.30.45	7.27.30.45
30/45 (set)	22.5	15	38	28	8.5	6.5	2xFF+2xFG	158	7.26.30.45.ST	7.27.30.45.ST
40/40 (pcs)	20	20	38	38	8.5	8.5		118	7.26.40.40	7.27.40.40
40/40 (set)	20	20	38	38	8.5	8.5	4xFG	186	7.26.40.40.ST	7.27.40.40.ST
40/45 (pcs)	22.5	20	38	38	8.5	8.5		118	7.26.40.45	7.27.40.45
40/45 (set)	22.5	20	38	38	8.5	8.5	4xFG	186	7.26.40.45.ST	7.27.40.45.ST
45/45 (pcs)	22.5	22.5	38	38	8.5	8.5		118	7.26.45.45	7.27.45.45
45/45 (set)	22.5	22.5	38	38	8.5	8.5	4xFG	186	7.26.45.45.ST	7.27.45.45.ST

Elementos de Puertas y Ventanas

Door and Window Elements

Bisagra
Hinge

Material y color: Aluminio anodizado gris / Anodized aluminium grey

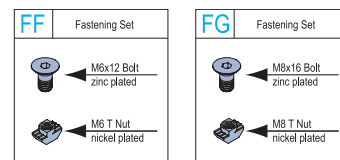
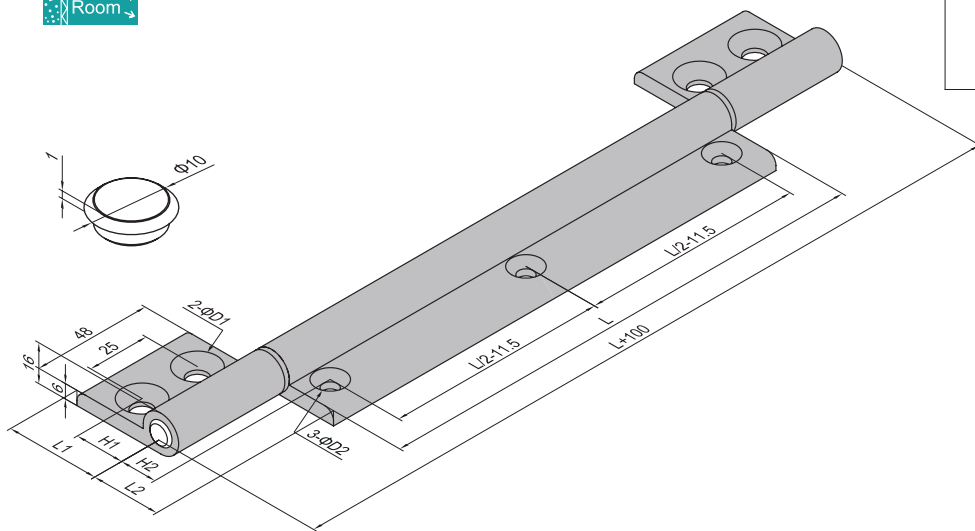
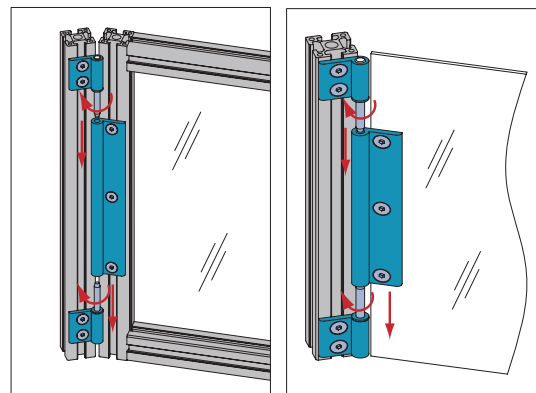

Descripción	H1 (mm)	H2 (mm)	L1 (mm)	L2 (mm)	D1 (mm)	D2 (mm)	L (mm)	Fastening Set	Masa (g)	Part No.
30/30 (pcs)	15	15	28	28	6.5	6.5	500		502	7.28.30.30
30/30 (set)	15	15	28	28	6.5	6.5		7×FF	558	7.28.30.30.ST
30/40 (pcs)	20	15	38	28	8.5	6.5			512	7.28.30.40
30/40 (set)	20	15	38	28	8.5	6.5		3×FF+4×FG	604	7.28.30.40.ST
30/45 (pcs)	22.5	15	38	28	8.5	6.5			512	7.28.30.45
30/45 (set)	22.5	15	38	28	8.5	6.5		3×FF+4×FG	604	7.28.30.45.ST
40/40 (pcs)	20	20	38	38	8.5	6.5			587	7.28.40.40
40/40 (set)	20	20	38	38	8.5	6.5		7×FG	706	7.28.40.40.ST
40/45 (pcs)	22.5	20	38	38	8.5	8.5			587	7.28.40.45
40/45 (set)	22.5	20	38	38	8.5	8.5		7×FG	706	7.28.40.45.ST
45/45 (pcs)	22.5	22.5	38	38	8.5	8.5			587	7.28.45.45
45/45 (set)	22.5	22.5	38	38	8.5	8.5		7×FG	706	7.28.45.45.ST

Nota: El largo puede ser personalizado de acuerdo al requerimiento del cliente de 100 ~ 1000mm
 The length can be customized according to customer requirements from 100 ~ 1000mm
 Ejemplo / Example: 7.28.30.30 - 500

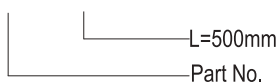

Elementos de Puertas y Ventanas

Door and Window Elements

Cerradura
Lock

Cerradura compacta de metal diseñada para auto trabarse.
Compact metal lock with self-locking design.

Material y color: Fundición de zinc con tratamiento de electrofóresis color negro
Die Cast Zinc with black electrophoresis treatment

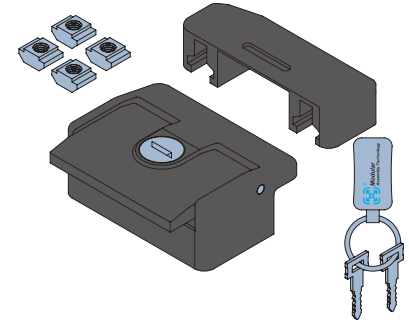
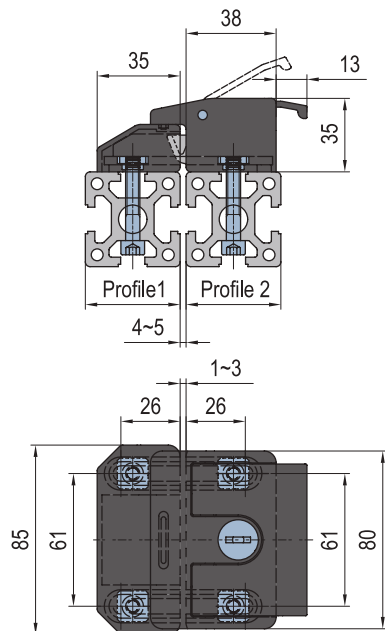
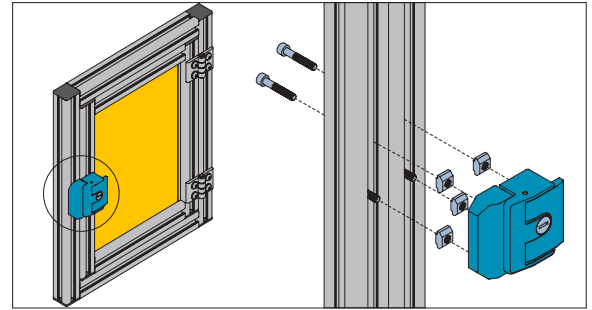

Descripción	Perfil 1	Perfil 2	Fastening Set	Masa (g)	Part No.
Lock-3030	PG30	PG30	4x(M6x30)	719	7.31.30.30
Lock-4030	PG40	PG30	2x(M6x30) 2x(M6x40)	724	7.31.40.30
Lock-4040	PG40	PG40	4x(M6x40)	728	7.31.40.40
Lock-4530	PG45	PG30	2x(M6x30) 2x(M6x45)	726	7.31.45.30
Lock-4540	PG45	PG40	2x(M6x40) 2x(M6x45)	731	7.31.45.40
Lock-4545	PG45	PG45	4x(M6x45)	733	7.31.45.45

Elementos de Puertas y Ventanas
Door and Window Elements

Cerradura
Lock

Material y color: Fundición de zinc cromado y pulido superficial
Die Cast Zinc chromed with polish finish

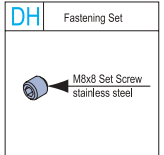
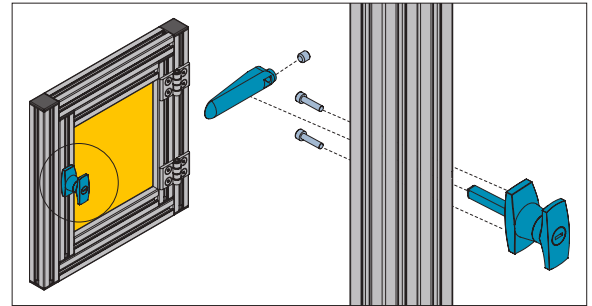
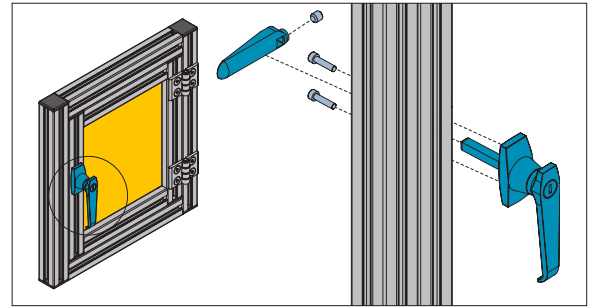
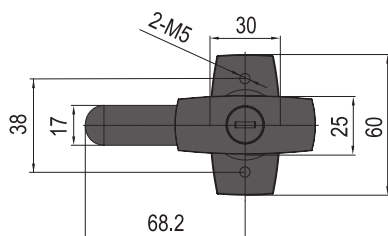
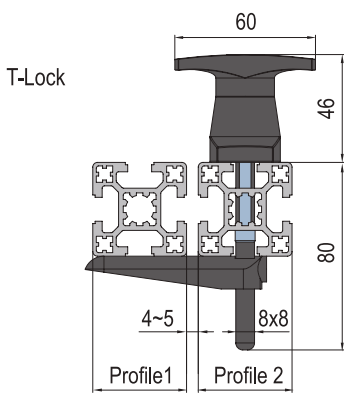
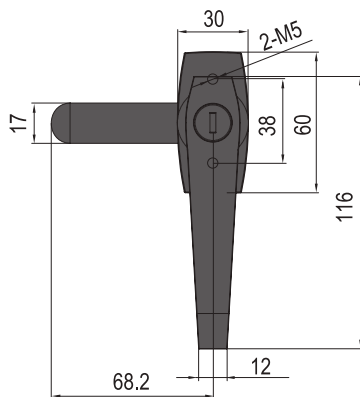
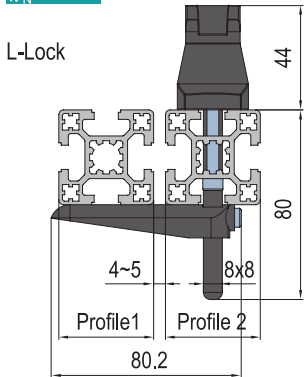

Descripción	Perfil 1	Perfil 2	Fastening Set	Masa (g)	Part No.
L-Lock-3030	PG30	PG30	DH+2x(M5x25)	290	7.32.30.30
L-Lock-4030	PG40	PG30			7.32.40.30
L-Lock-4530	PG40	PG40			7.32.45.30
L-Lock-4040	PG40	PG40	DH+2x(M5x35)	294	7.32.40.40
L-Lock-4540	PG45	PG40			7.32.45.40
L-Lock-4545	PG45	PG45	DH+2x(M5x40)	296	7.32.45.45
T-Lock-3030	PG30	PG30	DH+2x(M5x25)	270	7.33.30.30
T-Lock-4030	PG40	PG30			7.33.40.30
T-Lock-4530	PG40	PG40			7.33.45.30
T-Lock-4040	PG40	PG40	DH+2x(M5x35)	274	7.33.40.40
T-Lock-4540	PG45	PG40			7.33.45.40
T-Lock-4545	PG45	PG45	DH+2x(M5x40)	276	7.33.45.45

Elementos de Puertas y Ventanas
Door and Window Elements

Cierre Magnético
Magnet Catch

Material: Cierre-aleación de aluminio / conectores-acero al carbono zincado
Magnet Catch-aluminium alloy / Connectors-Zinc plated steel

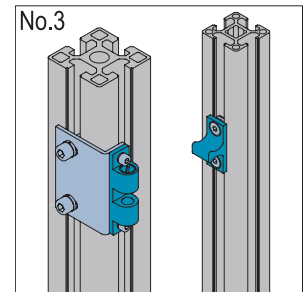
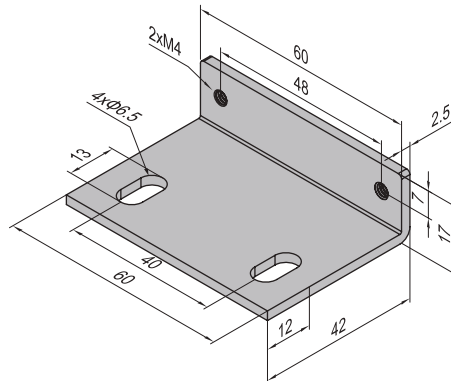
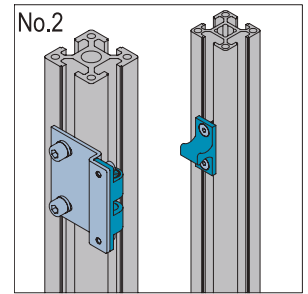
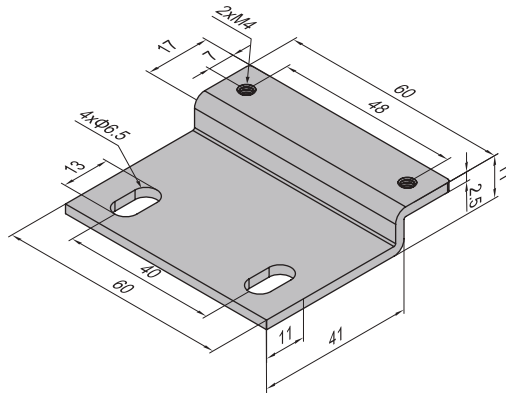
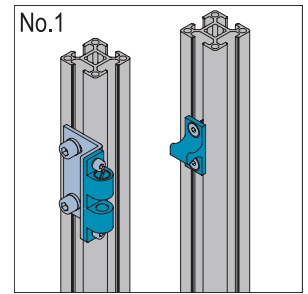
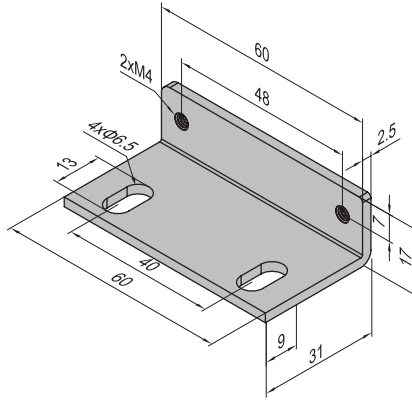
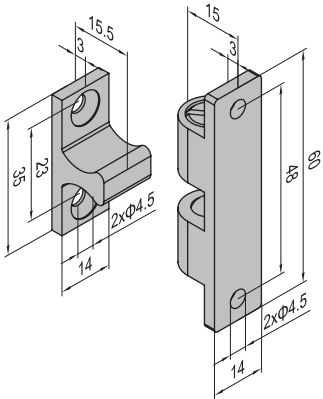

CF Fastening Set 	CH Fastening Set 	CJ Fastening Set 	CK Fastening Set 	CN Fastening Set
-----------------------------	-----------------------------	-----------------------------	-----------------------------	-----------------------------

Descripción	Fastening Set	Masa (g)	Part No.
Magnet Catch-14 (pcs)		26	7.41.14
Magnet Catch-14 (Profile 3030 for Door, Profile 3030 for Doorframe set No.1)	2xCF+2xCH+2xCJ	130	7.41.14.3030.ST
Magnet Catch-14 (Profile 3030 for Door, Profile 4040 for Doorframe set No.2)	2xCF+2xCH+2xCK	139	7.41.14.3040.ST
Magnet Catch-14 (Profile 3030 for Door, Profile 4545 for Doorframe set No.3)	2xCF+2xCH+2xCN	145	7.41.14.3045.ST

Elementos de Puertas y Ventanas
Door and Window Elements

Cierre Magnético
Magnet Catch

Material: Cierre-aleación de aluminio / conectores-acero al carbono zincado
Magnet Catch-aluminium alloy / Connectors-Zinc plated steel

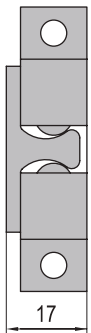

Tighten Status 1

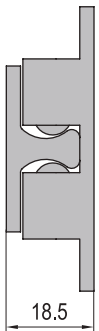

Tighten Status 2

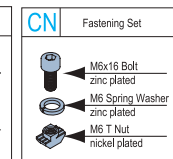
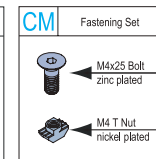
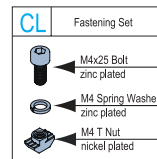
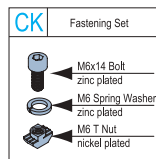
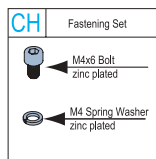
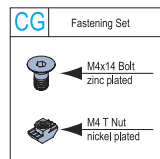
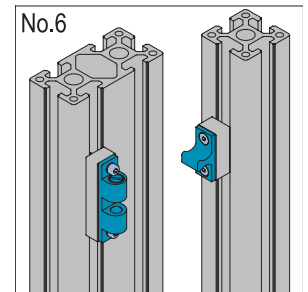
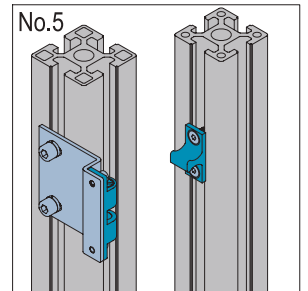
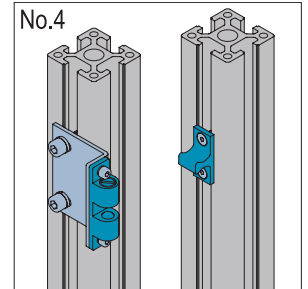
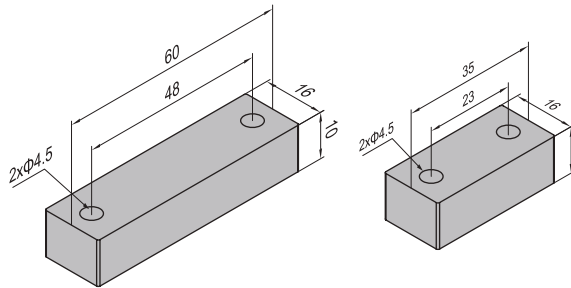
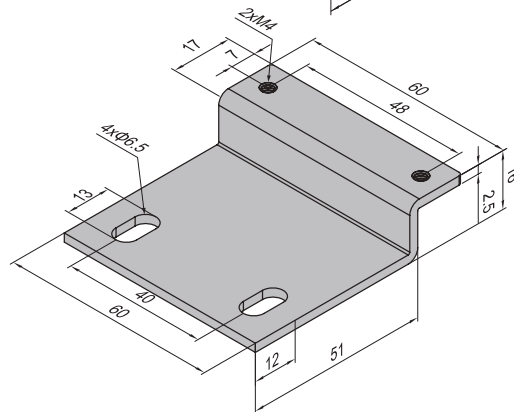
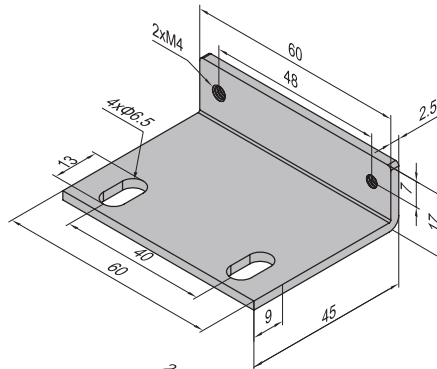

Descripción	Fastening Set	Masa (g)	Part No.
Magnet Catch-14 (Profile 4040 for Door, Profile 4040 for Doorframe set No.4)	2xCG+2xCH+2xCK	147	7.41.14.4040.ST
Magnet Catch-14 (Profile 4040 for Door, Profile 4545 for Doorframe set No.5)	2xCG+2xCH+2xCN	151	7.41.14.4045.ST
Magnet Catch-14 (Profile 4040 for Door, Profile 4080 for Doorframe set No.6)	2xCL+2xCM	255	7.41.14.4080.ST
Magnet Catch-14 (Profile 4545 for Door, Profile 4545 for Doorframe set No.4)	2xCG+2xCH+2xCK	151	7.41.14.4545.ST

Elementos de Puertas y Ventanas
Door and Window Elements

Cerradura de Puerta
Door Lock

Material y color: Fundición de zinc con tratamiento de electroforesis color negro
Die Cast Zinc with black electrophoresis treatment

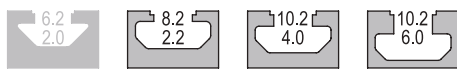
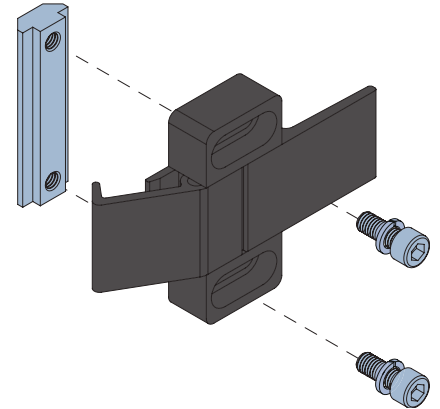
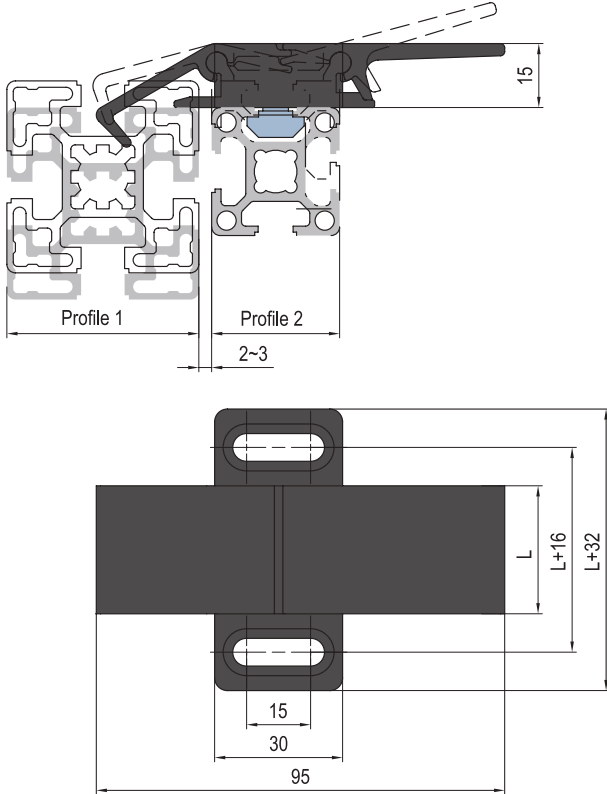
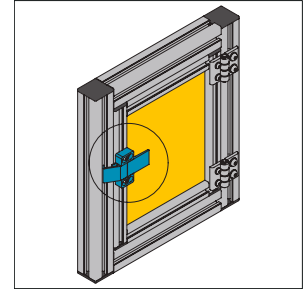

CU	Fastening Set	CV	Fastening Set
	M6x16 Bolt zinc plated		M6x20 Bolt zinc plated
	M6 Spring Washer zinc plated		M6 Spring Washer zinc plated

Descripción	Perfil 1	Perfil 2	L (mm)	Fastening Set	Masa (g)	Part No.
Door locks-3040	PG40	PG30	30	2xCU	115	7.42.30.3040
Door locks-3045	PG45	PG30	30	2xCU	115	7.42.30.3045
Door locks-4040	PG40	PG40	30	2xCU	115	7.42.30.4040
Door locks-4045	PG45	PG40	50	2xCU	115	7.42.30.4045
Door locks-4545	PG45	PG45	50	2xCV	120	7.42.30.4545

Nota: El largo puede ser personalizado de acuerdo al requerimiento del cliente de 30 ~ 80mm

Elementos de Puertas y Ventanas

Door and Window Elements

Perfil de Puerta Corrediza
Sliding Door Profile

El Perfil de Puerta Corrediza encaja en la ranura T del perfil de aluminio y es apto para puertas corredizas livianas.
The Sliding Door Profile fits into strut profiles and is suitable for light-weight sliding doors.

Material y color: PVC gris / grey

Sliding door profile-8

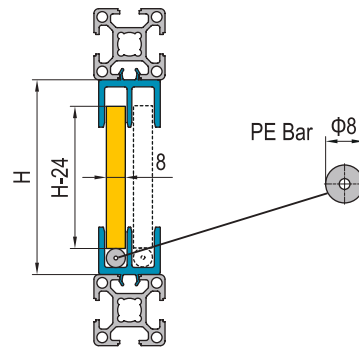
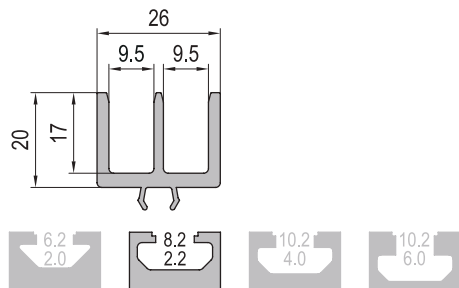

Sliding door profile-10-4

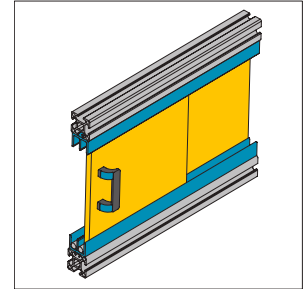
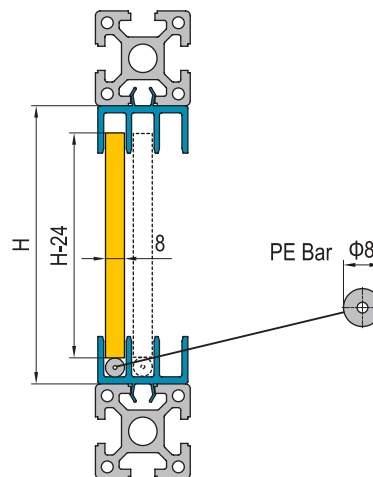
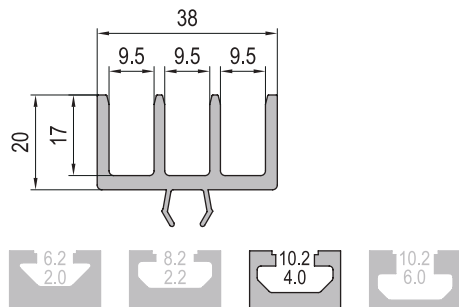

Descripción	Masa (g/m)	Largo	Part No.
Sliding Door Profile-8	330	3000mm/bar	7.51.08
Sliding Door Profile-8 (Including PE bar)	390	3000mm/bar	7.51.08.ST
Sliding Door Profile-10-4	450	3000mm/bar	7.51.10.04
Sliding Door Profile-10-4 (Including PE bar)	510	3000mm/bar	7.51.10.04.02.ST
Sliding Door Profile-10-4 (Including PE bar)	540	3000mm/bar	7.51.10.04.03.ST



8.11-8.61

Gancho de Suspensión
Suspended Glider

Platina de Ángulo Giratorio
Swivel Angle Plate

Unión 0-180°
Joint 0-180°

Unión para Bastidores
Frame Joint

Adaptador p/Montaje de Rodillo
Mounting Adaptor for Roller

8

Accesorios Adicionales *Additional Accessories*

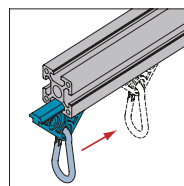

8.11.01

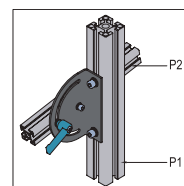

8.21.01

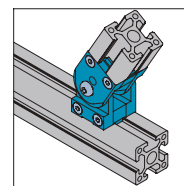

8.31.01

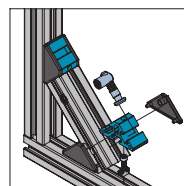

8.41.01

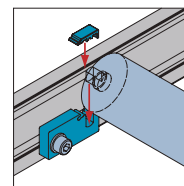

8.51.01

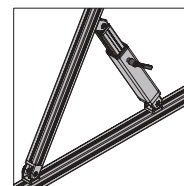

8.61.01

Accesorios Adicionales

Additional Accessories

Gancho de Suspensión Suspended Glider

El Gancho de Suspensión se encaja en el perfil de ranura T y se utiliza para colgar herramientas y demás accesorios.
Suspender Glider fits the strut profil and is suitable to hang tools and other accessories.

Material y color: Soporte-PA6 negro / gancho-acero al carbono zincado.
Glider-PA6 black / Hook-Zinc plated steel

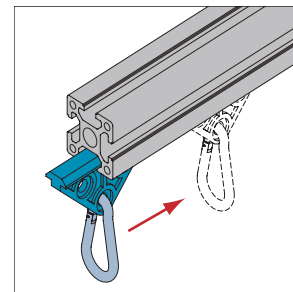

Suspended Glider-8

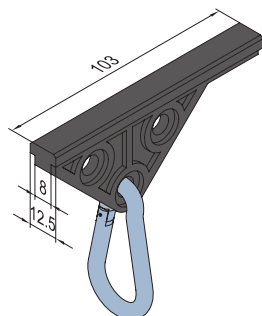

Descripción	Carga Estática Máx. (N)	Masa (g)	Part No.
Suspended Glider-8	200	48	8.11.08

Suspended Glider -10

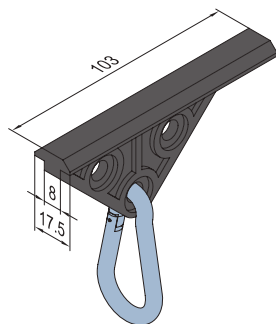

Descripción	Carga Estática Máx. (N)	Masa (g)	Part No.
Suspended Glider-10	200	48	8.11.10

Accesorios Adicionales

Additional Accessories

Platina de Ángulo Giratorio Swivel Angle Plate

La Platina de Ángulo Giratorio permite ajustar la inclinación del perfil conectado a ella.
Swivel Angle Plate allows to adjust the incline angle of the profile frame.

Material y color: Acero al carbono con tratamiento de electroforesis color negro
Mild steel with black electrophoresis treatment

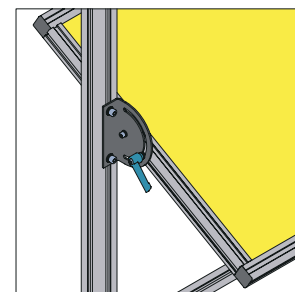
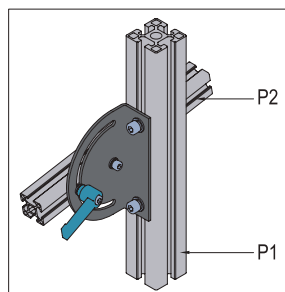

Swivel Angle Plate-PG30

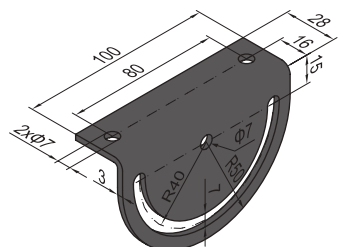

Swivel Angle Plate-PG40/45

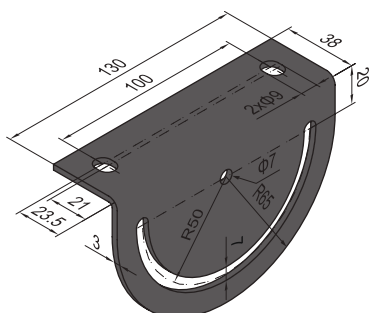

FR	FT	FV	FW	R
Fastening Set	Fastening Set	Fastening Set	Fastening Set	Fastening Set
M6x12 Adjustable Handle Elastic coated, black	M6x12 Bolt zinc plated	M6x16 Bolt zinc plated	M6x16 Bolt zinc plated	M6x12 Bolt zinc plated
M6 Washer zinc plated	M6 Washer zinc plated	M6 Washer zinc plated	M6 Washer zinc plated	M6 Washer zinc plated
M6 Pre-set Nut nickel plated	M6 Pre-set Nut nickel plated	M6 T Nut nickel plated	M6 Pre-set Nut nickel plated	M6 T Nut nickel plated

Descripción	P1	P2	Fastening Set	Masa (g)	Part No.
Swivel Angle Plate-PG30 (pcs)				160	8.21.30
Swivel Angle Plate-PG30 (set)	PG30	PG30	1xFR+1xFT+2xR	270	8.21.30.ST
Swivel Angle Plate-PG40/45 (pcs)				288	8.21.40
Swivel Angle Plate-PG40/45-PG30 (set)	PG40/45	PG30	1xFR+1xFT+2xFV	420	8.21.40.30.ST
Swivel Angle Plate-PG40/45-PG40/45 (set)	PG40/45	PG40/45	1xFR+2xFV+1xFW	443	8.21.40.40.ST

Accesorios Adicionales

Additional Accessories

Unión 0-180°

Joint 0-180°

Se utiliza para conectar perfiles que requieren movimiento.

It is used to connect profiles that require movement.

Material: Acero al carbono zincado / Zinc plated steel



Joint-Type A

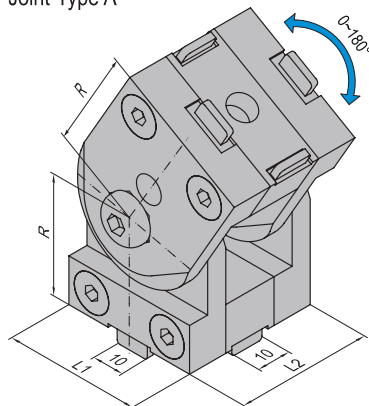



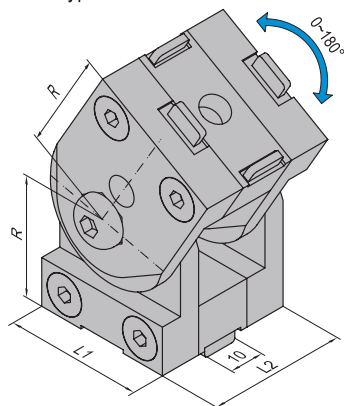

Joint-Type B

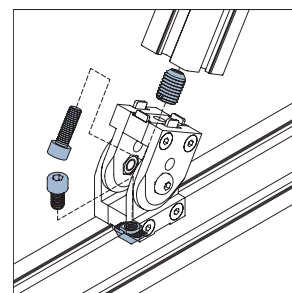
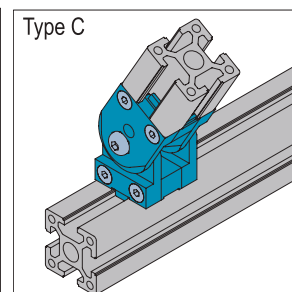
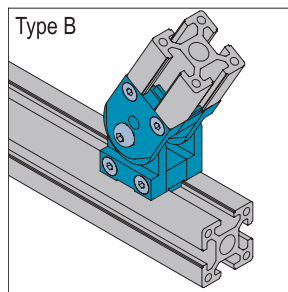
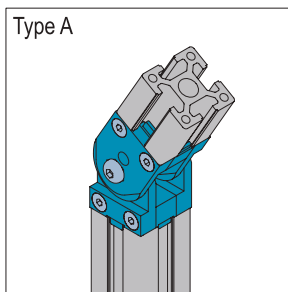
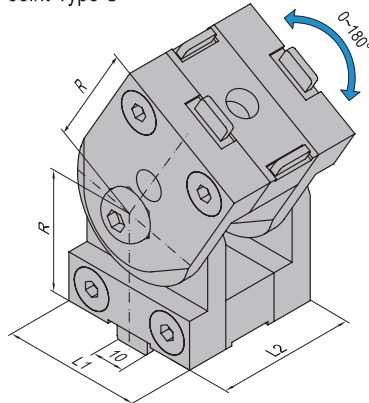

Joint-Type C



FD	Fastening Set	FX	Fastening Set
	M8x16 Bolt zinc plated		M8x20 Bolt zinc plated
	M8 T Nut nickel plated		M14-M8 Hole Reducer Bolt nickel plated

Descripción	L1 (mm)	L2 (mm)	R (mm)	Fastening Set	Masa (g)	Part No.
Joint-Type A-4040	40	40	35	2xFX	560	8.31.4040A
Joint-Type A-4060	40	60	35	2xFX	680	8.31.4060A
Joint-Type A-4545	45	45	37.5	2xFX	650	8.31.4545A
Joint-Type A-4560	45	60	37.5	2xFX	800	8.31.4560A
Joint-Type B-4040	40	40	35	1xFD+1xFX	575	8.31.4040B
Joint-Type B-4060	40	60	35	1xFD+1xFX	695	8.31.4060B
Joint-Type B-4545	45	45	37.5	1xFD+1xFX	665	8.31.4545B
Joint-Type B-4560	45	60	37.5	1xFD+1xFX	815	8.31.4560B
Joint-Type C-4040	40	40	35	1xFD+1xFX	575	8.31.4040C
Joint-Type C-4060	40	60	35	1xFD+1xFX	695	8.31.4060C
Joint-Type C-4545	45	45	37.5	1xFD+1xFX	665	8.31.4545C
Joint-Type C-4560	45	60	37.5	1xFD+1xFX	815	8.31.4560C

Accesorios Adicionales

Additional Accessories

Unión para Bastidores
Frame Joint

La Unión para Bastidores se utiliza para dar rigidez a bastidores de aluminio utilizados en la construcción de máquinas.
The Frame Joint is used to provide bracing and stability to large machine frames.

Material: Perfil-aluminio extruido / tapa-ABS negro
Profile-Extruded Aluminium / Cap-ABS black

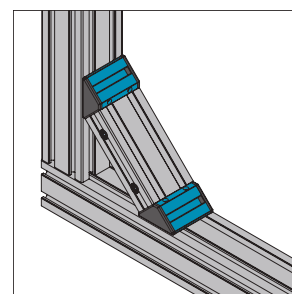
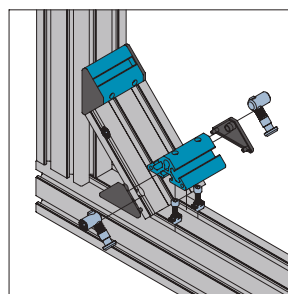
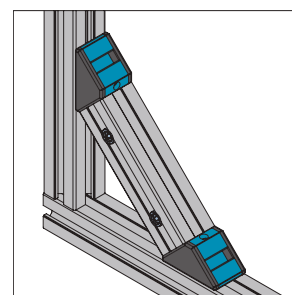
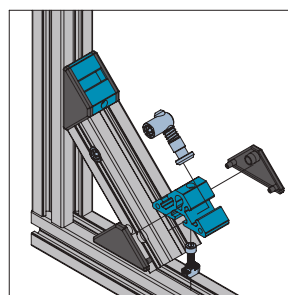
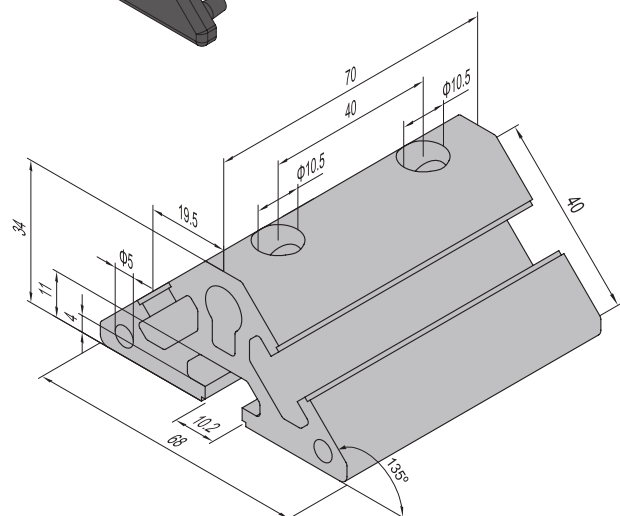
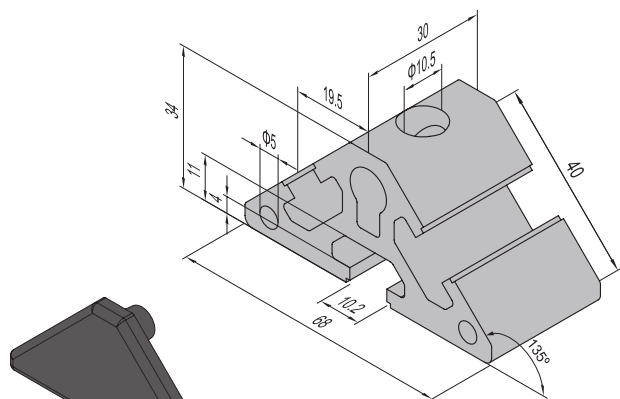
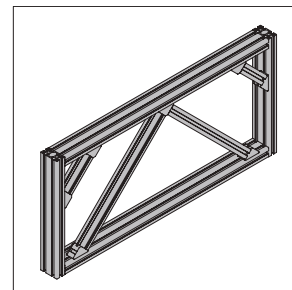

Descripción	Fastening Set	Tapa	Masa (g)	Part No.
PG40-4040 (set)	1xCB	2	95	8.41.4040
PG40-4080 (set)	2xCB	2	192	8.41.4080

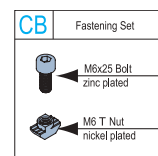

Accesorios Adicionales

Additional Accessories

Adaptador para Montaje de Rodillos
 Mounting Adaptor for Roller

El Adaptador para Montaje de Rodillos permite la instalación rápida y sencilla de rodillos sin necesidad de desmontar la estructura.
 Mounting Adaptor for Roller allows quick free roller installation.

Material y color: Adaptador-fundición de hierro zincada / tapa-PA6 negro
 Adaptor-Die Cast Steel Zinc Plated / Cap-PA6 black

Mounting Adaptor for Roller-A

End Cap

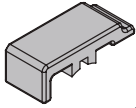

End Cap

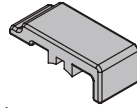

Left

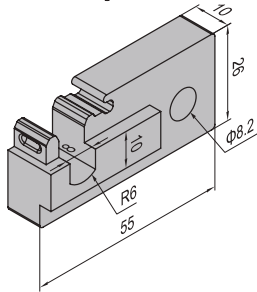

Right

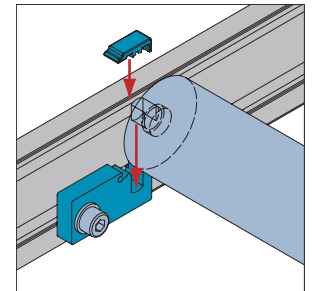
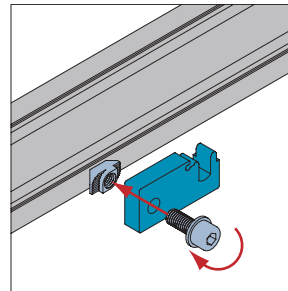
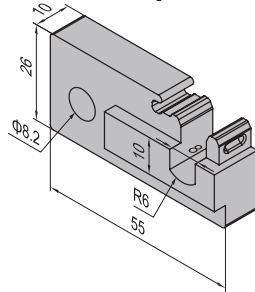

Mounting Adaptor for Roller-B

End Cap

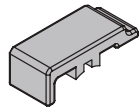

End Cap

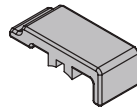



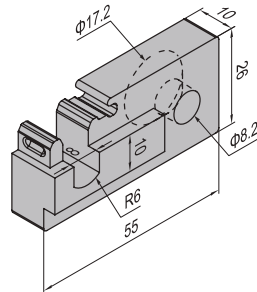

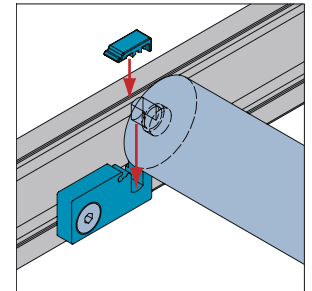
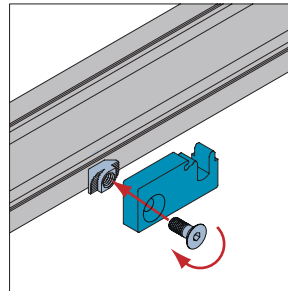
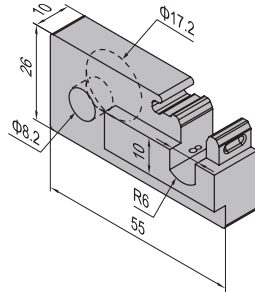

Left



Right



Descripción	Fastening Set	Tapa	Masa (g)	Part No.
Mounting Adaptor for Roller-A-Left+Right (pcs)		2	200	8.51.01A
Mounting Adaptor for Roller-A-Left+Right (set)	2xD	2	242	8.51.01A.ST
Mounting Adaptor for Roller-B-Left+Right (pcs)		2	194	8.51.01B
Mounting Adaptor for Roller-B-Left+Right (set)	2xFQ	2	226	8.51.01B.ST

D	Fastening Set	FQ	Fastening Set
	M8x20 Bolt zinc plated		M8x20 Bolt zinc plated
	M8 Washer zinc plated		M8 Washer zinc plated
	M8 T Nut nickel plated		M8 T Nut nickel plated

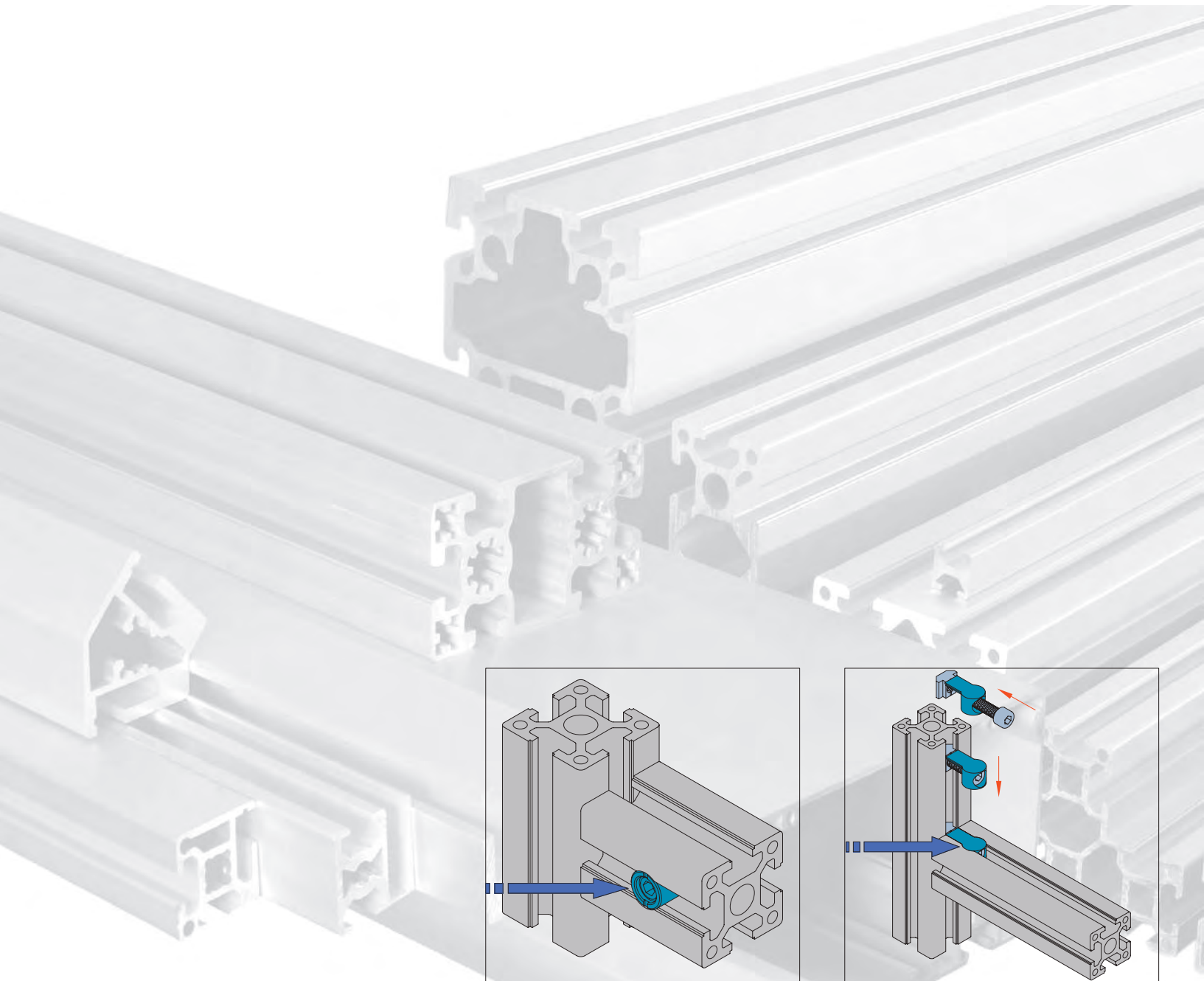

Código de Maquinado de Perfiles *Profile Machining Code*

Dowel Bore

Alterations		Dowel bore			
		Left		Right	
		Horizontal	Vertical	Horizontal	Vertical
Code		LDH	LDV	RDH	RDV
Square					
Rectangle			—		—
Arc					
			—		—

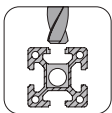

Example A: 1. 11. 40.040040.04H-200-LDH/RDH

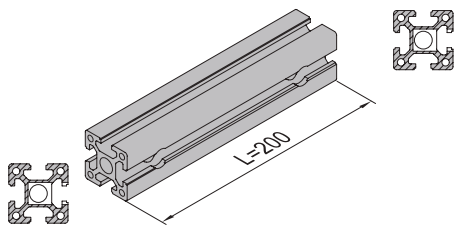

Example B: 1. 11. 40.040080.08H-200-LDV/RDH

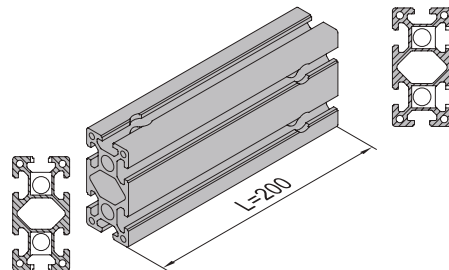

Inner Connect Bore

Alterations		Inner connect bore			
		Left		Right	
		Horizontal	Vertical	Horizontal	Vertical
Code		LIH	LIV	RIH	RIV
Square					
		—		—	
			—		—
Rectangle					
Arc					
			—		—

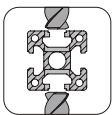

Example A: 1. 11. 40.040040.04H-200-LIH/RIH

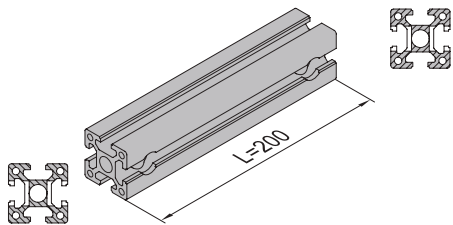

Example B: 1. 11. 40.040080.08H-200-LIV/RIH

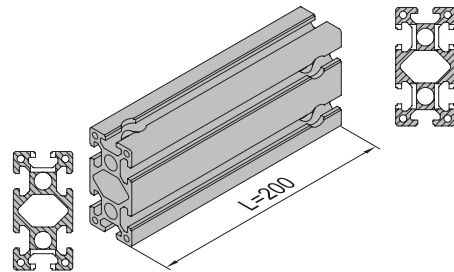

Screw Thread Bore

Alterations		Screw thread bore					
		Left		Right		Left+ Right	
Code		LSP	LMP	RSP	RMP	WSP	WMP
Square							
			—				
Rectangle							
Arc							

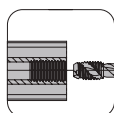

Standard: depth=22mm

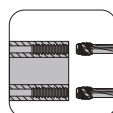

Standard: depth=22mm

Example A:

1. 11. 40.040040.04H-200-LSP

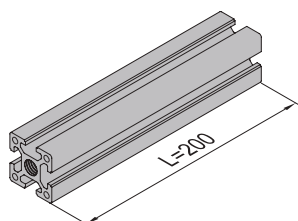

Example B:

1. 11. 40.040080.08H-200-WSP

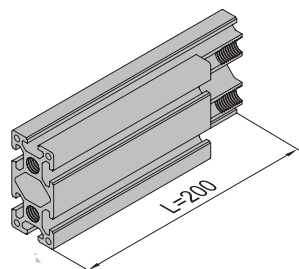

Example C:

1. 11.40.040040.04H-200-LMP

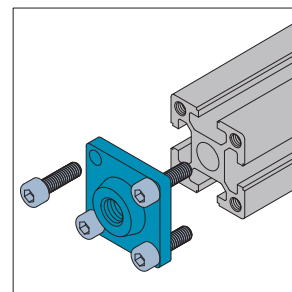
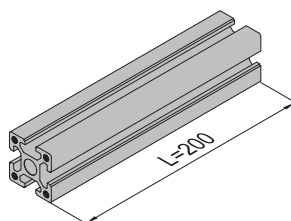

Cross Bore

Alterations		Cross bore					
		Left			Right		
Code	Image	Horizontal	Vertical	H+V	Horizontal	Vertical	H+V
		LCH	LCV	LCP	RCH	RCV	RCP
Square							
Rectangle							

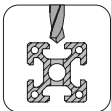

Specified crossing bore code

LC□/RC□-A□L-B□L-...Z□L



Example: 1. 11. 40.040040.04H-400-LCH/RCH-AH120-BP230

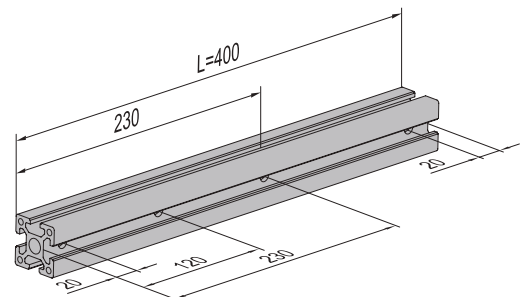

Angle Cut

Alterations		Angle cut	
		Left	Right
Code		LCT(LAT,LBT,LDT)	RCT(RAT,RBT,RDT)
Square			
Rectangle			

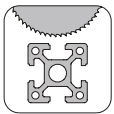

Specified cutting angle code

Example: 1. 11. 40. 040060.06H-300-LDT45/RDT45

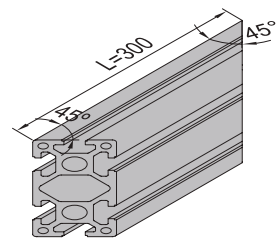

L□Tα:

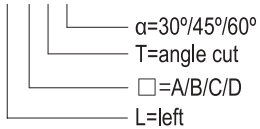

R□Tα:

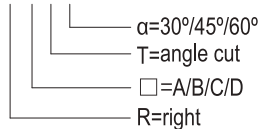

□=A向

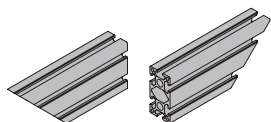

□=B向

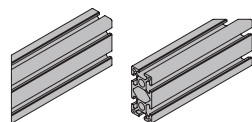

□=C向

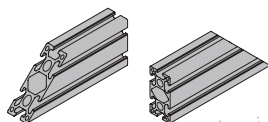

□=D向

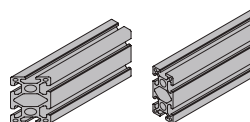



Sistema de Ensamble Modular
Modular Assembly System

MAS



Sistema de Transportadores Modulares
Modular Conveyor System

MCS



Sistema de Plataformas y Escaleras
Stair and Platform System

SPS



Sistema de Cerramientos de Seguridad
Machine Guard System

MGS



Sistema de Estructuras Tubulares
Tubular Framing System

TFS



Alutipo SRL
Web: www.alutipo.com
Email: info@alutipo.com

Modular Assembly System