

Tubular Framing System



Sistema de Estructuras Tubulares
Tubular Framing System





Sistema de Estructuras Tubulares
Tubular Framing System

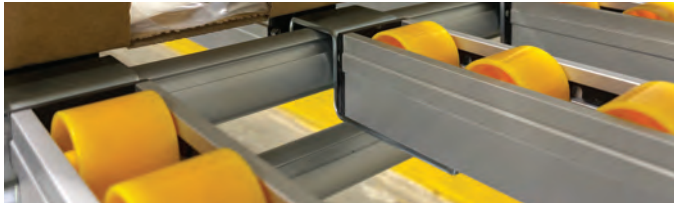

Sistema de Estructura Tubular *Tubular Framing System*

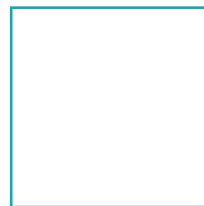
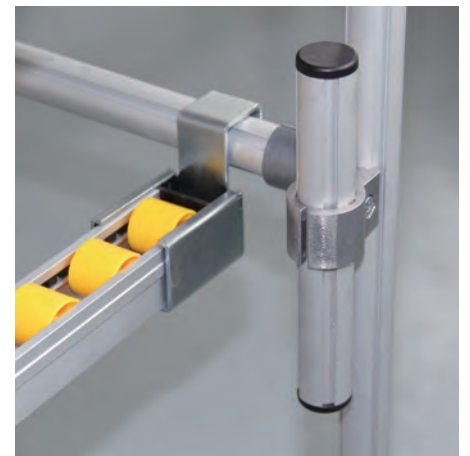
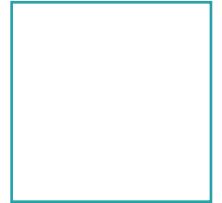

Sistema de estructuras Tubulares

Tubular Framing System

El Sistema de Estructuras Tubulares (TFS) es un sistema modular flexible compuesto de perfiles tubulares y sus accesorios correspondientes, brindando una amplia gama de posibilidades. Flow Racks, transportadores, estaciones de trabajo o cualquier otro sistema estructural. La característica clave de este sistema es su fácil manipulación, ofreciendo una máxima eficiencia en costos.

Tubular Framing System (TFS) is a flexible modular system composed of profile tubes and accessories to build a diverse range of possible flow racks, material shuttles, workstations and any other frame system. Simple handling is the key feature of TFS and delivers maximum cost efficiency.

Características

Features

Simple / Easy concept	Versátil / Versatile	Eficiente / Efficient	Reutilizable / Reusable	Atractivo / Attractive design
<p>Módulos simples y de fácil combinación.</p> <p><i>Simple and easy-to-combine modules</i></p>	<p>Brinda diferentes posibilidades debido a su composición modular, permitiendo al usuario reconfigurar estructuras de acuerdo a su necesidad.</p> <p><i>It offers different possibilities due to its modular nature, allowing the user to reconfigure structures according to their needs.</i></p>	<p>Ensamble rápido, y estable. Contempla diversas necesidades dentro de la industria. Excelente relación calidad precio.</p> <p><i>Quick and stable assembly. It addresses various needs within the industry. Best value for money.</i></p>	<p>Excelente durabilidad. Los perfiles y accesorios pueden ser reutilizados, dando un nuevo ciclo de vida al producto.</p> <p><i>Profiles and Accessories can be reused, giving a new life cycle to the product.</i></p>	<p>Forma, Función y Estética combinadas para ofrecerte la mejor solución.</p> <p><i>Combine aesthetic appeal with creative problem-solving.</i></p>

Aplicaciones





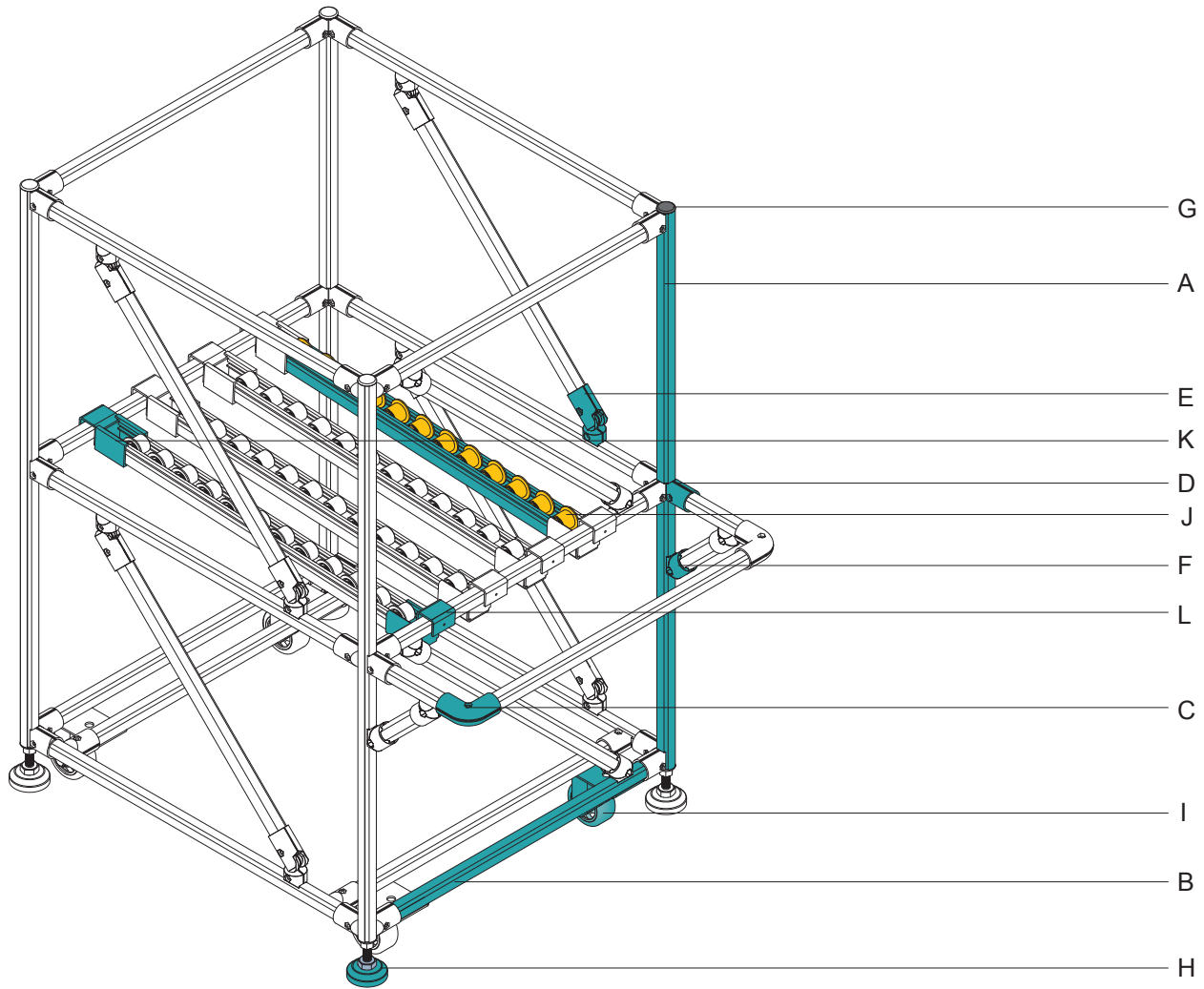

Applications

Este sistema es ampliamente utilizado en fábricas, depósitos y especialmente en procesos de montaje de la industria electrónica y automotriz. Es una herramienta esencial para las integraciones de logística.

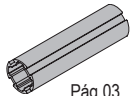
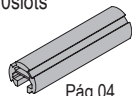
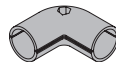

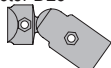

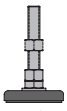

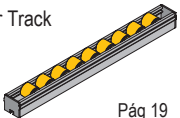
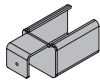
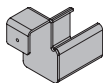

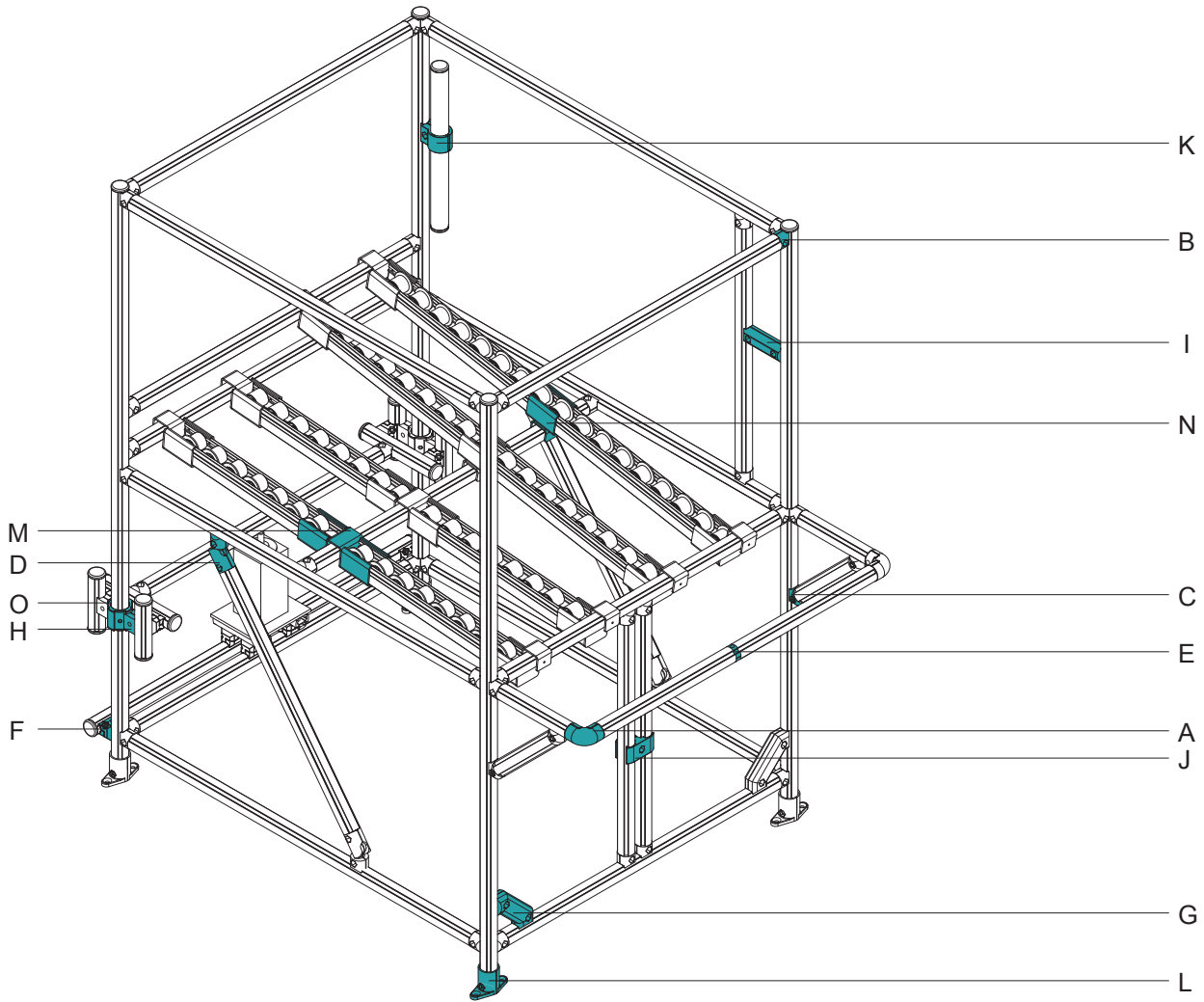

This system is widely used in factories, warehouses and especially in assembly processes such as electronics and automotive industries. It is an essential tool for logistics integrations.

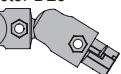

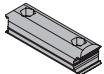

<p>A Profile Tube D28</p>  <p>Pág 03</p>	<p>B Profile Tube D28, 10slots</p>  <p>Pág 04</p>	<p>C L Outer Connector D28</p>  <p>Pág 07</p>	<p>D 90° Outer Connector D28</p>  <p>Pág 07</p>
<p>E 0-80° Outer Connector D28</p>  <p>Pág 08</p>	<p>F 45° Outer Connector D28</p>  <p>Pág 07</p>	<p>G Cap</p>  <p>Pág 13</p>	<p>H Leveling Foot</p>  <p>Pág 15</p>
<p>I Castor</p>  <p>Pág 16</p>	<p>J Flow Roller Track</p>  <p>Pág 19</p>	<p>K Flat Rail Holder</p>  <p>Pág 20</p>	<p>L High Rail Holder</p>  <p>Pág 20</p>

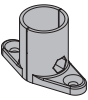
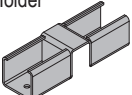



<p>A L Inner Connector D28</p>  <p>Pág 08</p>	<p>B 90° Inner Connector D28</p>  <p>Pág 09</p>	<p>C 45° Inner Connector D28</p>  <p>Pág 09</p>	<p>D 0-80° Inner Connector D28</p>  <p>Pág 09</p>
<p>E Linear Inner Connector D28</p>  <p>Pág 10</p>	<p>F Cross Connector D28</p>  <p>Pág 10</p>	<p>G 45° Bracing Strut D28</p>  <p>Pág 10</p>	<p>H Parallel ConnectorA D28</p>  <p>Pág 11</p>
<p>I Parallel ConnectorB D28</p>  <p>Pág 11</p>	<p>J Parallel Adapter D28</p>  <p>Pág 11</p>	<p>K Single Adapter D28</p>  <p>Pág 12</p>	<p>L T Base D28</p>  <p>Pág 17</p>
<p>M Bilateral Flat Rail Holder</p>  <p>Pág 21</p>	<p>N Cross Rail Holder</p>  <p>Pág 21</p>	<p>O Slide Adapter D28</p>  <p>Pág 23</p>	

Perfil Tubular
Tube Profile

El perfil tubular TFS presenta una tolerancia estandar según norma GB 5237-2008. El tratamiento de la superficie es anodizado satinado. La longitud estándar de los perfiles es de 5800mm.

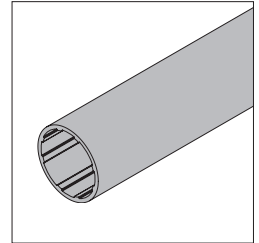
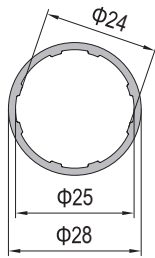
TFS Profile Tube applies standard tolerance of GB 5237-2008, the surface treatment is satin anodized. Standard length of delivery profiles is 5800mm.

Tubo D28
Tube D28

 El Tubo D28 puede ser unido mediante conectores internos o externos.
Tube D28 can be connected by inner or outer connectors.

Descripción	Momento Inercia $I_x(\text{cm}^4)$	Momento Inercia $I_y(\text{cm}^4)$	Módulo Resistente $W_x(\text{cm}^3)$	Módulo Resistente $W_y(\text{cm}^3)$	Masa (kg/m)	Part No.
Tube D28	1.3	1.3	0.9	0.9	0.36	TFS.D28

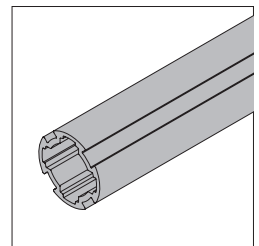
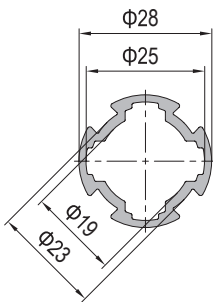
Perfil Tubular D28
Profile Tube D28

Descripción	Momento Inercia $I_x(\text{cm}^4)$	Momento Inercia $I_y(\text{cm}^4)$	Módulo Resistente $W_x(\text{cm}^3)$	Módulo Resistente $W_y(\text{cm}^3)$	Masa (kg/m)	Part No.
Profile Tube D28	1.6	1.6	1.03	1.03	0.48	TFS.D28.1

Perfil Tubular
Profile Tube

Doble Perfil Tubular D28
Double Profile Tube D28

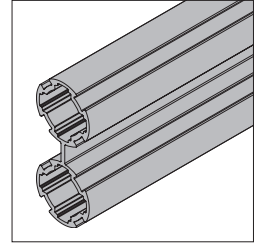
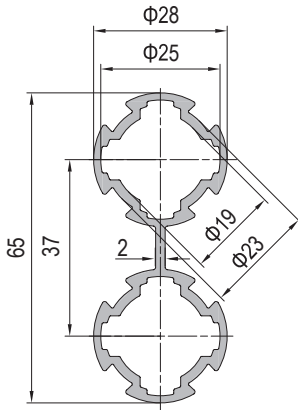

Descripción	Momento Inercia x(cm ⁴)	Momento Inercia ly(cm ⁴)	Módulo Resistente Wx(cm ³)	Módulo Resistente Wy(cm ³)	Masa (kg/m)	Part No.
Double Profile Tube D28	14.97	2.67	4.6	1.9	1.15	TF.S.D28.1.D

Perfil Tubular D28-10
Profile Tube D28-10

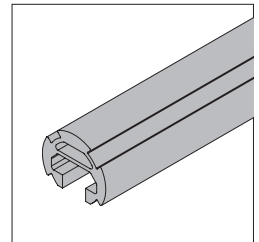
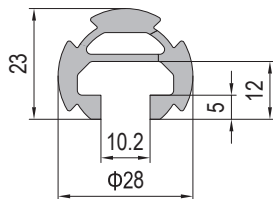

Descripción	Momento Inercia x(cm ⁴)	Momento Inercia ly(cm ⁴)	Módulo Resistente Wx(cm ³)	Módulo Resistente Wy(cm ³)	Masa (kg/m)	Part No.
Profile Tube D28-10	1.1	1.9	0.8	1.3	0.68	TF.S.D28.1.10

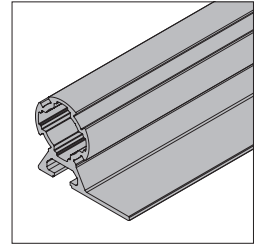
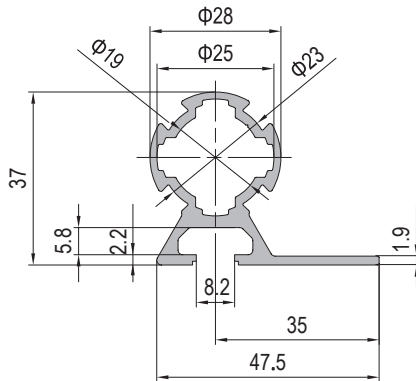
Perfil Tubular
Profile Tube
Perfil Tubular SW D28-8
SW Profile Tube D28-8

Descripción	Momento Inercia $x(\text{cm}^4)$	Momento Inercia $y(\text{cm}^4)$	Módulo Resistente $W_x(\text{cm}^3)$	Módulo Resistente $W_y(\text{cm}^3)$	Masa (kg/m)	Part No.
SW Profile Tube D28-8	5.7	2.95	3.1	1.24	0.86	TFS.D28.1.SW

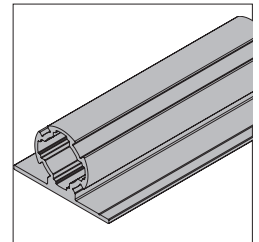
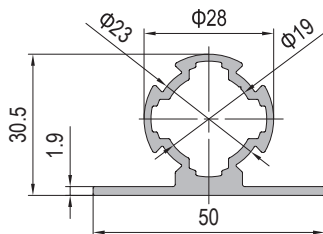
Perfil Tubular DW D28
DW Profile Tube D28

Descripción	Momento Inercia $x(\text{cm}^4)$	Momento Inercia $y(\text{cm}^4)$	Módulo Resistente $W_x(\text{cm}^3)$	Módulo Resistente $W_y(\text{cm}^3)$	Masa (kg/m)	Part No.
DW Profile Tube D28	3.35	2.95	1.2	1.18	0.79	TFS.D28.1.DW

Conectores
Connectors

Los Perfiles Tubulares D28 se pueden unir fácilmente mediante conectores de diferentes ángulos.
Profile Tube D28 can be joined together easily by connectors of different angles.

Capacidad de Carga
Loading Capacity

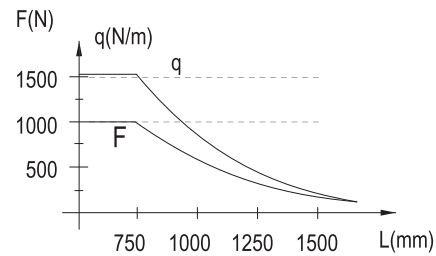
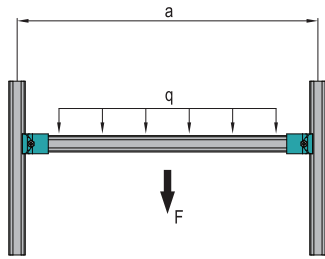

Alternativas de Instalación
Installation Alternatives

Los conectores se pueden dividir según la forma de instalación, en conectores interiores o exteriores.
Connectors can be divided by the way of installation into outer and inner connectors.

Instalación para conectores exteriores / Outer connectors installation

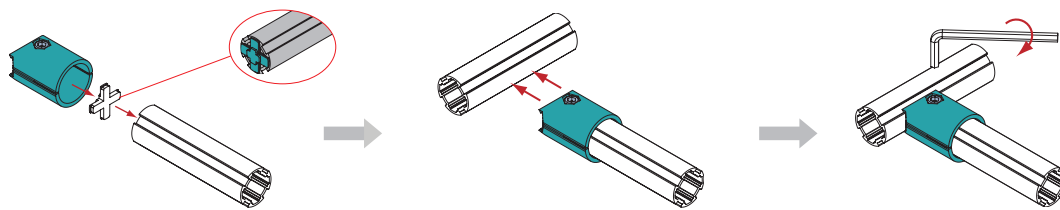

Anti-Torsion Block
Material: PA6

Anti-Torsion Block se ordena por separado, ver en Pág.13.

Instalación para conectores interiores / Inner connectors installation

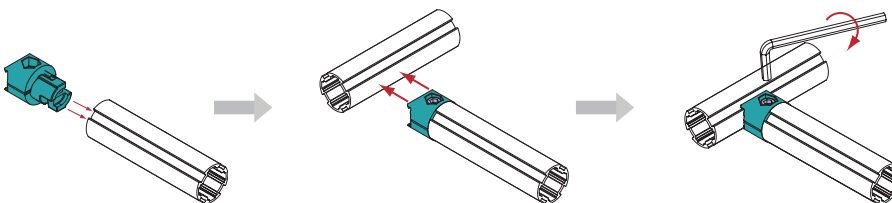

Conectores
Connectors

Conector Externo Tipo L D28
L Outer Connector D28

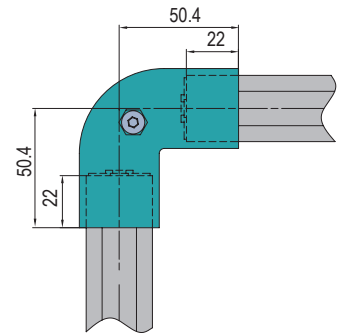
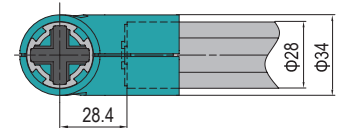
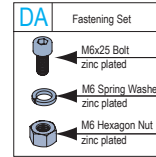
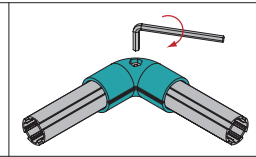
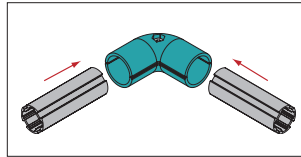
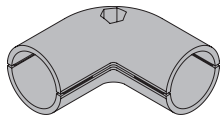

Descripción	Material	Fastening Set	Anti-Torsion Block	Masa (g)	Part No.
L Outer Connector D28	Diecast Aluminum	1XDA	2X	117	TFS.D28.2.01.01

Conector Externo 90° D28
90° Outer Connector D28

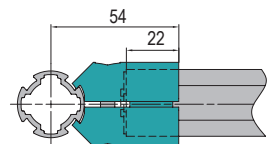
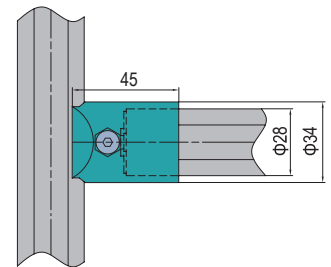
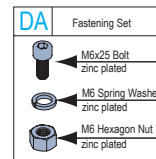
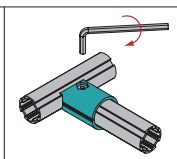
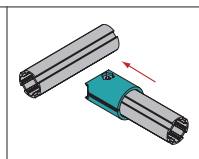
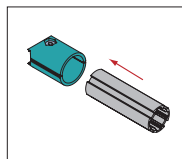
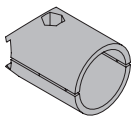

Descripción	Material	Fastening Set	Anti-Torsion Block	Masa (g)	Part No.
90° Outer Connector D28	Diecast Aluminum	1XDA	1X	55	TFS.D28.2.01.02

Conector Externo 45° D28
45° Outer Connector D28

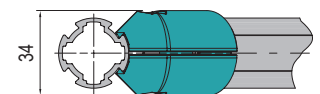
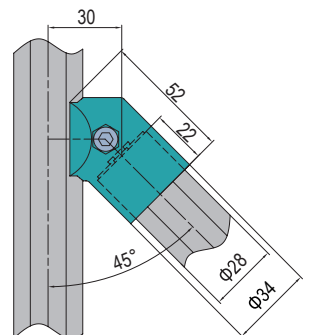
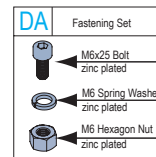
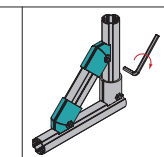
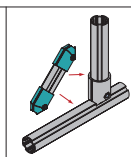
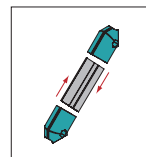
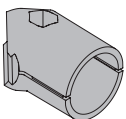

Descripción	Material	Fastening Set	Anti-Torsion Block	Masa (g)	Part No.
45° Outer Connector D28	Diecast Aluminum	1XDA	1X	57	TFS.D28.2.01.03

Conectores
Connectors

Conector Externo 0-80° D28
0-80° Outer Connector D28

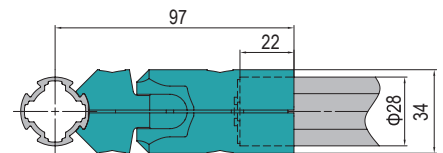
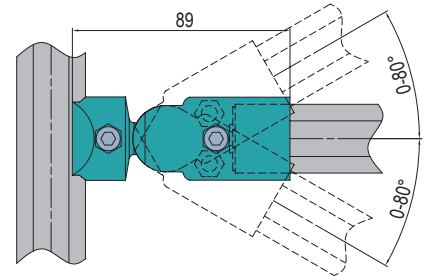
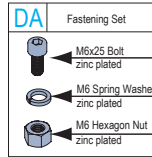
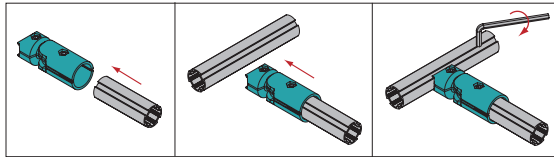
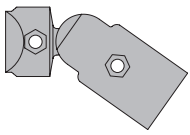

Descripción	Material	Fastening Set	Anti-Torsion Block	Masa (g)	Part No.
0-80° Outer Connector D28	Diecast Aluminum	2XDA	1X	132	TFS.D28.2.01.04

Conector Externo para Doble Perfil Tubular 90°D28
90° Outer Connector for Double Profile Tube D28

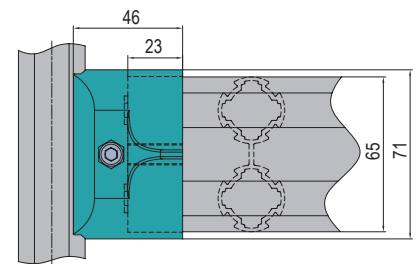
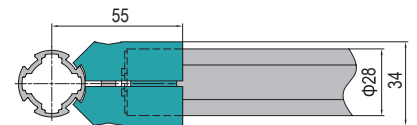
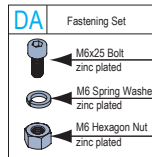
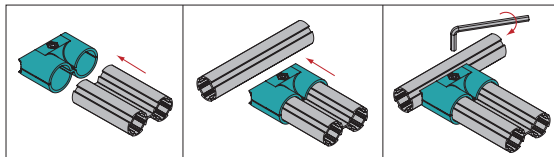
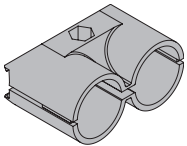

Descripción	Material	Fastening Set	Masa (g)	Part No.
90° Outer Connector for Double Profile Tube D28	Diecast Aluminum	1XDA	143.5	TFS.D28.2.01.05

Conector Interno Tipo L D28
L Inner Connector D28

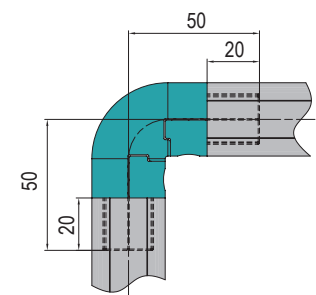
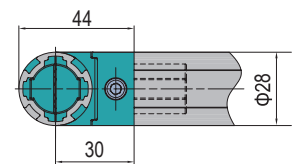
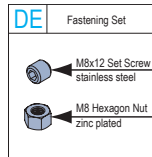
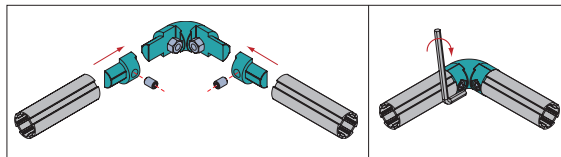
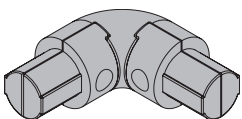

Descripción	Material	Fastening Set	Masa (g)	Part No.
L Inner Connector D28	Diecast Aluminum	2XDE	117.5	TFS.D28.2.02.01

Conectores
Connectors

Conector Interno a 90° D28
90° Inner Connector D28

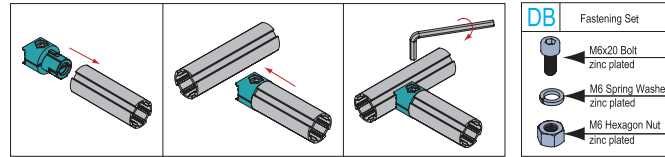
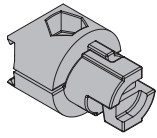

DB	Fastening Set
	M6x20 Bolt zinc plated
	M6 Spring Washer zinc plated
	M6 Hexagon Nut zinc plated

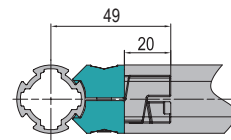
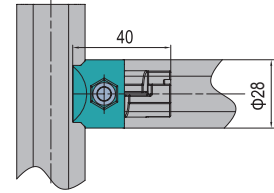

Descripción	Material	Fastening Set	Masa (g)	Part No.
90° Inner Connector D28	Diecast Aluminum	1XDB	51.5	TFS.D28.2.02.02

Conector Interno a 45° D28
45° Inner Connector D28

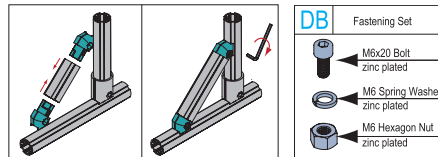
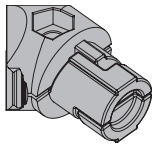

DB	Fastening Set
	M6x20 Bolt zinc plated
	M6 Spring Washer zinc plated
	M6 Hexagon Nut zinc plated

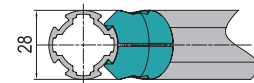
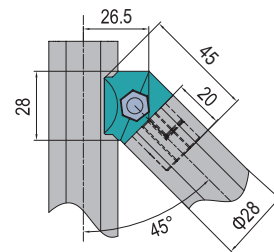

Descripción	Material	Fastening Set	Masa (g)	Part No.
45° Inner Connector D28	Diecast Aluminum	1XDB	41.5	TFS.D28.2.02.03

Conector Interno a 0-80° D28
0-80° Inner Connector D28

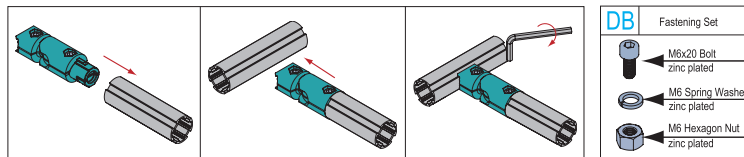
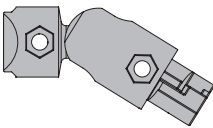

DB	Fastening Set
	M6x20 Bolt zinc plated
	M6 Spring Washer zinc plated
	M6 Hexagon Nut zinc plated

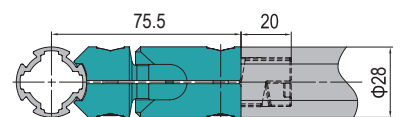
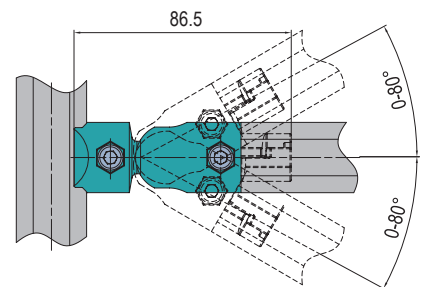

Descripción	Material	Fastening Set	Masa (g)	Part No.
0-80° Inner Connector D28	Diecast Aluminum	2XDB	109	TFS.D28.2.02.04

Conectores
Connectors

Conector Interior Lineal D28
Linear Inner Connector D28

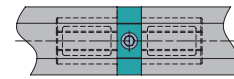
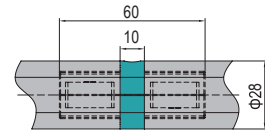
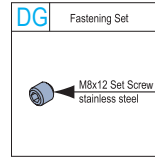
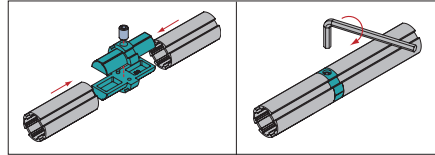
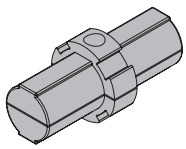

Descripción	Material	Fastening Set	Masa (g)	Part No.
Linear Inner Connector D28	Diecast Aluminum	1XDG	42	TFS.D28.2.02.05

Conector Transversal D28
Cross Connector D28

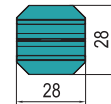
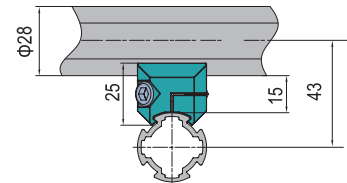
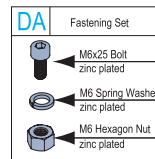
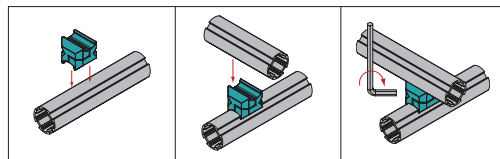

Descripción	Material	Fastening Set	Masa (g)	Part No.
Cross Connector D28	Diecast Aluminum	1XDA	43	TFS.D28.2.03.01

Escuadra de refuerzo a 45° D28
45° Bracing Strut D28

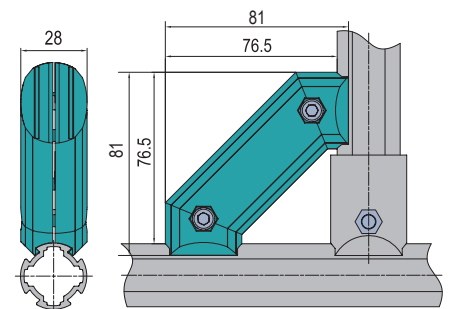
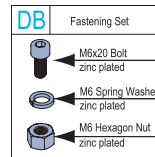
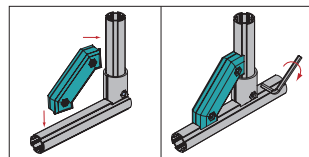
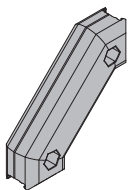

Descripción	Material	Fastening Set	Masa (g)	Part No.
45° Bracing Strut D28	Diecast Aluminum	2XDB	180	TFS.D28.2.03.02

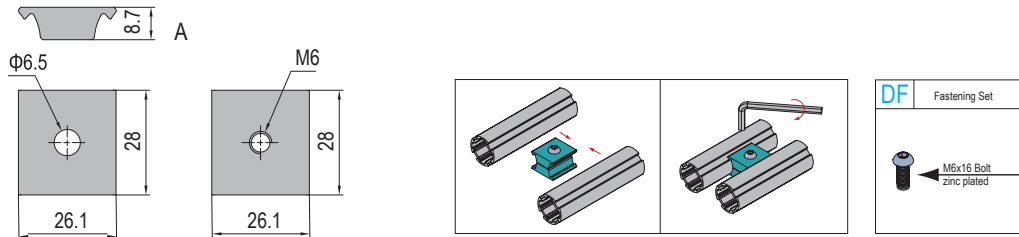
Conectores
Connectors
Conector Paralelo A D28
Parallel Connector A D28

Descripción	Material	Fastening Set	Masa (g)	Part No.
Parallel Connector A D28	Aluminum Alloy	1XDF	22	TFS.D28.2.03.03

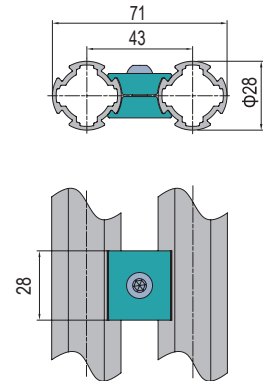
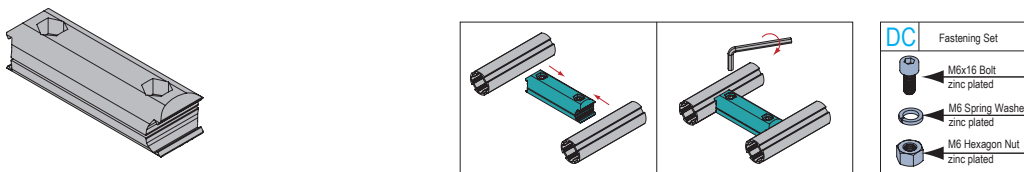
Conector Paralelo B D28
Parallel Connector B D28

Descripción	Material	Fastening Set	Masa (g)	Part No.
Parallel Connector B D28	Diecast Aluminum	2XDC	107	TFS.D28.2.03.04

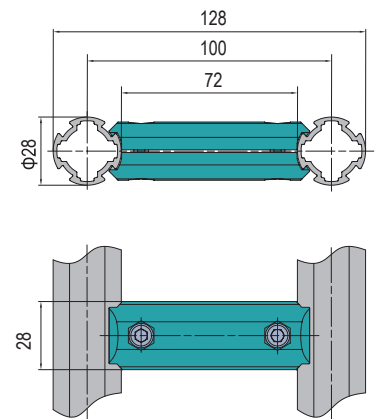
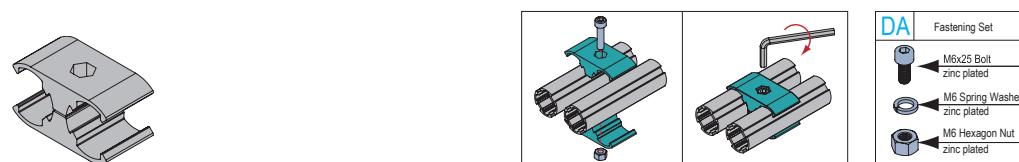

Adaptador Paralelo D28
Parallel Adapter D28

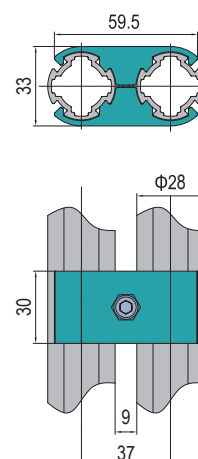
Descripción	Material	Fastening Set	Masa (g)	Part No.
Parallel Adapter D28	Diecast Aluminum	1XDA	67.5	TFS.D28.2.03.05

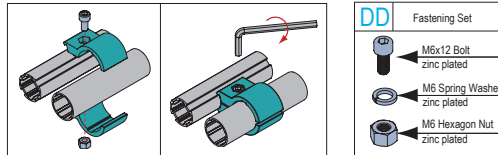
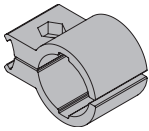

Conectores
Connectors

Adaptador Simple D28
Single Adapter D28



DD	Fastening Set
	M6x12 Bolt zinc plated
	M6 Spring Washer zinc plated
	M6 Hexagon Nut zinc plated

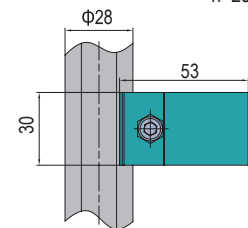
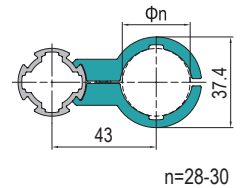

Descripción	Material	Fastening Set	Masa (g)	Part No.
Single Adapter D28	Diecast Aluminum	1XDD	60.5	TFS.D28.2.03.06

Accesorios de unión
Joint Accessories

Tapa
Cap

Material: ABS

La tapas para los extremos de los perfiles pueden prevenir el desgaste, ocultan bordes filosos y mejoran la apariencia del producto.

Caps can prevent wear, hide sharp edges and improve product appearance.

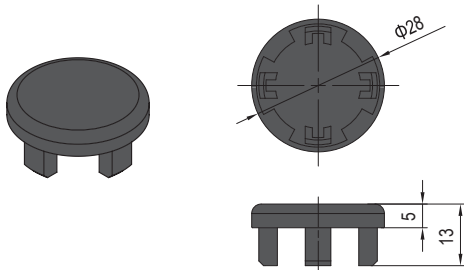
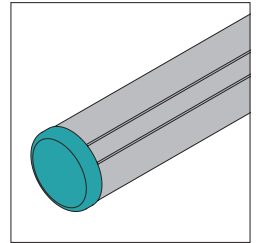

Descripción	Masa (g)	Part No.
Cap	2.6	TFS.D28.4.01

Listón de Apoyo o Deslizamiento
Slide Strip

Material y Color: PVC, Gris.

El listón de Apoyo se coloca sobre el perfil tubular D28 para crear el mismo plano horizontal de la pieza de unión.

Simply clip the Slide Strip onto profile tube D28 to create the same horizontal plane as the joint connector.

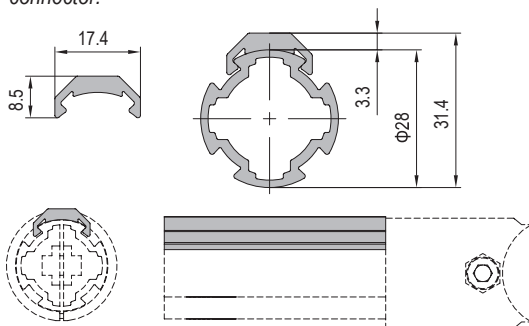
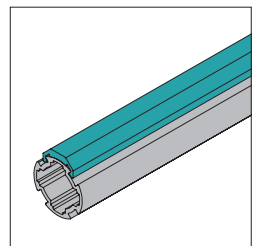
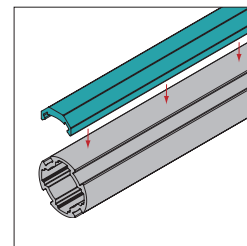

Descripción	Longitud	Masa (g/m)	Part No.
Slide Strip	2000mm/bar	83	TFS.D28.4.02

Pieza Anti-Torsión
Anti-Torsion Block

Material: PA6

El uso de esta pieza asegura que el perfil tubular quede correctamente alineado con el conector, y así evitar errores en el ensamble.

Using the Anti-Torsion Block ensures the profile tube is correctly aligned with the connector and avoid assembly errors.

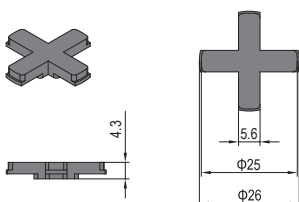
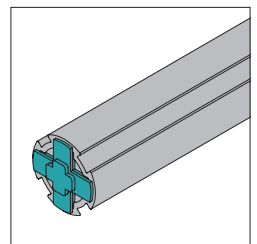

Descripción	Masa (g)	Part No.
Anti-Torsion Block	1	TFS.D28.4.03

Componentes de apoyo
Floor Elements

Inserto Roscado
Threaded Insert

Material: Acero Zincado

El inserto roscado se usa para fijar el perfil tubular al piso o para colocar ruedas.
Threaded Insert it is used to fix the tubular profile to the floor or to place wheels.

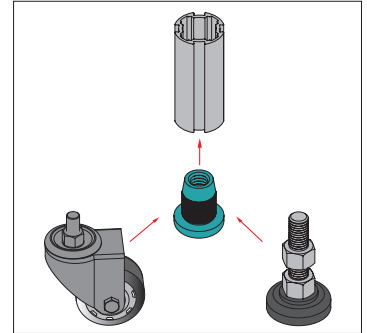
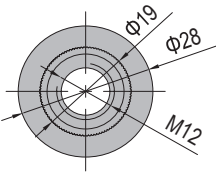
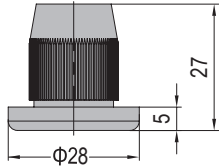

Descripción	Masa (g)	Part No.
Threaded Insert	47.6	TFS.D28.5.01.01

Pieza Anti Torsión en L
L Anti - Torsion Block

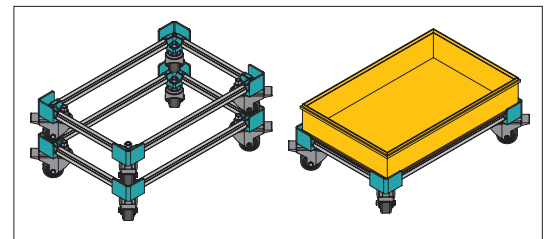
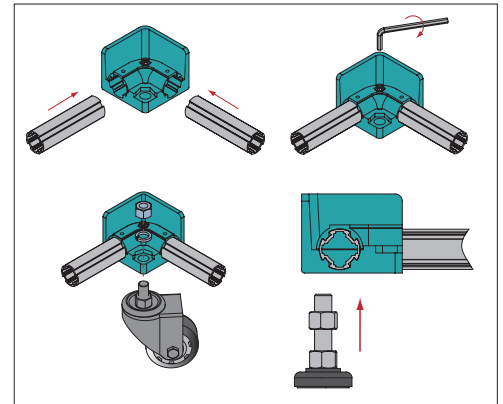
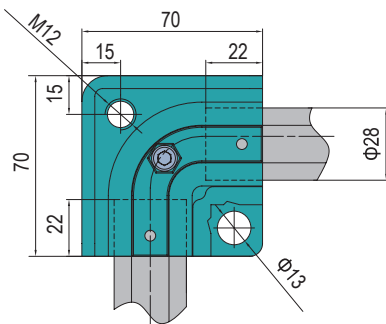
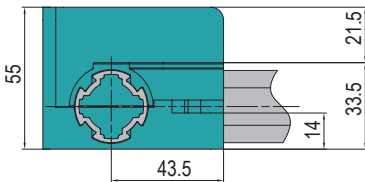

DA	Fastening Set
	M6x25 Bolt zinc plated
	M6 Spring Washer zinc plated
	M6 Hexagon Nut zinc plated

Descripción	Material	Fastening Set	Masa (g)	Part No.
L Anti-Torsion Block	Diecast Aluminum	1XDA	266	TFS.D28.5.02.01

⚠ Cuando esta pieza es usada con ruedas, el tamaño de dichas ruedas debe ser de $\Phi 63\text{mm}$.

When this part is used with wheels, the wheels size should be $\Phi 63\text{mm}$.

Componentes de apoyo

Floor Elements

Pata niveladora - Pata tipo pivot

Leveling Foot - Pivot Foot

La Pata tipo Pivot permite apoyar la estructura en zonas que requieren un ajuste gradual de altura. El pequeño ángulo de rotación absorbe las irregularidades del suelo. La conexión entre la base y la varilla roscada se puede desarmar mediante el uso de una herramienta.

The Pivot Foot is used to support the structure where gradual height adjustment is needed. The small swivel angle can absorb the slope of uneven floor. The connection between the pivot base and the spindle can be released with a tool.

Pata tipo pivot

Pivot Foot

Material y Color: Varilla roscada-acero al carbono zincado / Base-PA6 Negro
 Spindle-Zinc Plated Steel / Base-PA6 Black

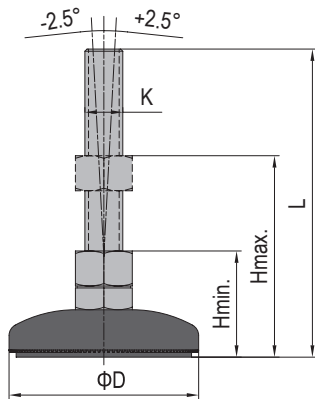

Descripción	D (mm)	KxL (mm)	H min. (mm)	H max. (mm)	Carga Estática Máx. (N)	Masa (g)	Part No.
Pivot Foot-PA 6 Base	59	M12x90	45	70	10000	152	5.21.60.12.90
	79	M12x90	45	70	10000	188	5.21.80.12.90
	79	M12x130	45	100	10000	218	5.21.80.12.130
	99	M12x130	45	100	10000	326	5.21.100.12.130

Por más información [Modular Assembly System](#)
 More information at



Pata niveladora - Pata giratoria

Leveling Foot - Swivel Foot

La pata giratoria permite apoyar la estructura en zonas que requieren un ajuste de altura. La rótula que existe entre la base y el perno, permite que la pata gire con un ángulo de hasta 30 grados. Se utiliza para equipos que necesitan ser movidos regularmente o que se apoyan en superficies irregulares.

The Swivel Foot is used to support the structure where gradual height adjustment is needed and where the floor slope is significant. The Swivel Foot has a ball joint between the base and the spindle that allows the foot to swivel up to an angle of 30°.

Pata giratoria

Swivel Foot

Material y Color: Varilla roscada-acero al carbono zincado / Base-PA6 Negro
 Spindle-Zinc Plated Steel / Base-PA6 Black

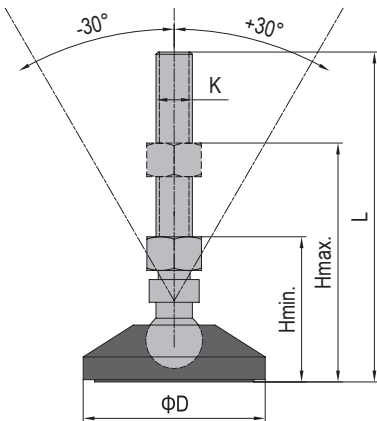

Descripción	D (mm)	KxL (mm)	H min. (mm)	H max. (mm)	Carga Estática Máx. (N)	Masa (g)	Part No.
Swivel Foot-PA 6 Base	59	M12x90	45	70	10000	162	5.22.60.12.90
	79	M12x90	45	70	10000	198	5.22.80.12.90
	79	M12x130	45	100	10000	228	5.22.80.12.130
	99	M12x130	45	100	10000	336	5.22.100.12.130

Por más información [Modular Assembly System](#)
 More information at



Componentes de apoyo
Floor Elements

Pata Niveladora - Pata fija
Leveling Foot - Fixed Foot

La Pata Fija permite apoyar la estructura en zonas que requieren un ajuste gradual de altura. La conexión entre la varilla roscada y la base es rígida.
Fixed Foot is used to support the structure where gradual height adjustment is needed. The connection between the spindle and the base is fixed.

Pata fija
Fixed Foot

Material y Color:
Varilla roscada-acero al carbono zincado / Base-acero al carbono pintada mediante electroforesis color Negro
Spindle-Zinc Plated Steel / Base-Mild Steel with Black electrophoresis

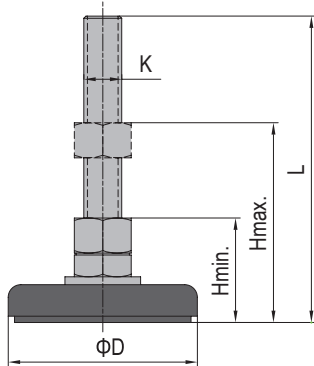

Descripción	D (mm)	KxL (mm)	H min. (mm)	H max. (mm)	Carga Estática Máx. (N)	Masa (g)	Part No.
Fixed Foot-Steel Base	40	M12x70	35	50	8000	124	5.23.40.12.70
	60	M12x70	35	50	8000	181	5.23.60.12.70
	80	M12x70	35	50	8000	220	5.23.80.12.70
	80	M12x110	35	80	8000	240	5.23.80.12.110

Por más informaciónModular Assembly System
More information at



Rueda
Castor

La rueda con rosca se conecta al perfil tubular mediante un inserto roscado.
Thread Castor is connected to tube profile by threaded insert.

Material: Base-acero al carbono con pintura electroestática color negro / rueda de poliuretano.
Base-Mild Steel with powder coating black / Wheel-polyurethane

Rueda con rosca
Castor-Thread-Universal

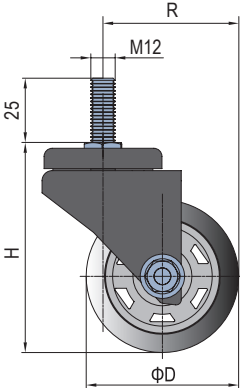

Rueda con rosca y freno
Castor-Thread-Brake

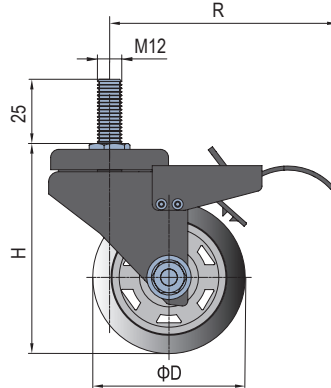

Descripción	D (mm)	R (mm)	H (mm)	Carga (N)	Masa (g)	Part No.
Castor-Thread-Universal	63	63	92	800	550	5.41.63.M12
	75	73	107	1050	670	5.41.75.M12
Castor-Thread-Brake	63	103	92	800	650	5.41.63.M12B
	75	103	107	1050	770	5.41.75.M12B

Componentes de apoyo
Floor Elements

Rueda Fija / Castor-Plate-Fixed

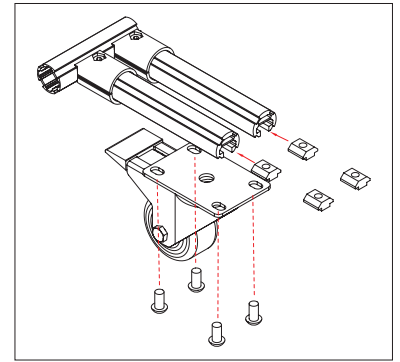
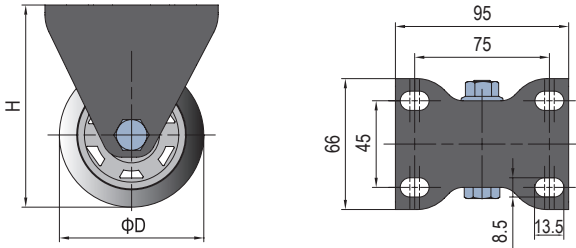

Rueda Giratoria / Castor-Plate-Universal

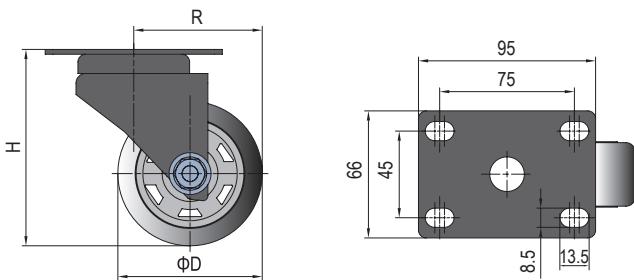

Rueda Giratoria con Freno / Castor-Plate-Brake

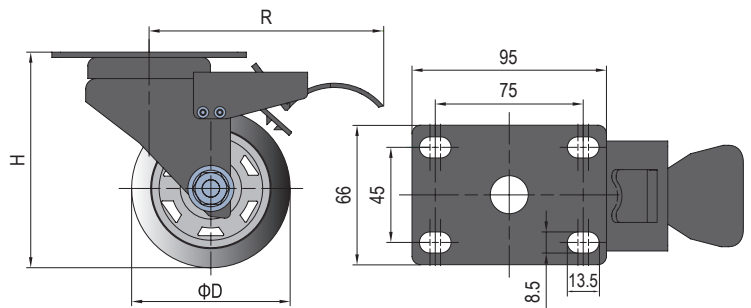

Descripción	D (mm)	R (mm)	H (mm)	Carga (N)	Masa (g)	Part No.
Castor-Plate-Fixed	63		92	800	370	5.41.63F
	75		107	1050	490	5.41.75F
Castor-Plate-Universal	63	63	92	800	570	5.41.63U
	75	73	107	1050	690	5.41.75U
Castor-Plate-Brake	63	103	92	800	670	5.41.63B
	75	103	107	1050	790	5.41.75B

Base D28 tipo T
T Base D28

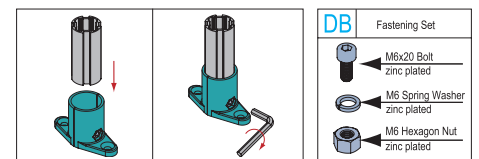
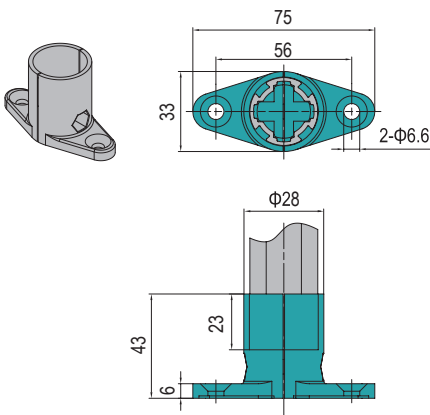

Descripción	Material	Fastening Set	Anti-Torsion Block	Masa (g)	Part No.
T Base D28	Diecast Aluminum	1XDB	1X	72	TFS.D28.5.03.01

Accesorios del panel
Panel Accessories

Material: Aleación de aluminio, anodizado.

Adaptador de Panel A
Panel Adapter A

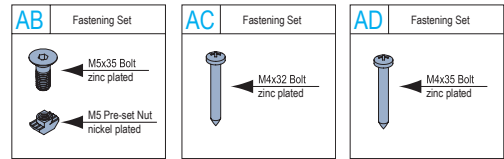
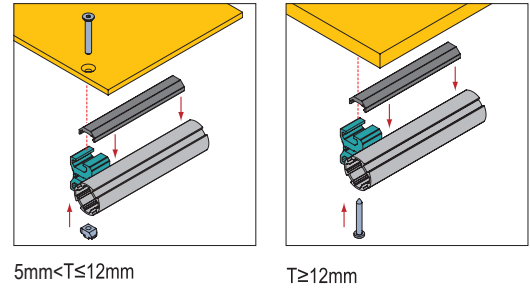
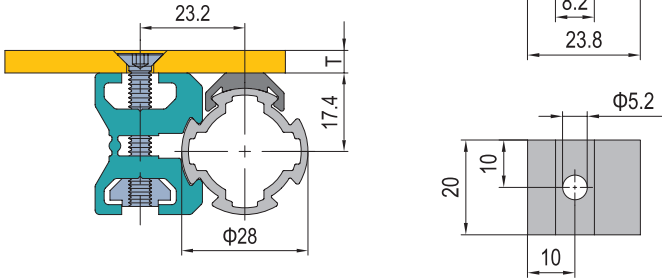

Descripción	Espesor	Material	Fastening Set	Masa (g)	Part No.
Panel Adapter A	5mm < T ≤ 12mm	metal, wood, or glass	1XAB	20	TFS..D28.6.01.01
	T=12mm	wood panel	1XAC	20	TFS.D28.6.01.02
	T > 12mm		1XAD	20	TFS.D28.6.01.03

El listón de Apoyo se ordena por separado, ver Página 13.

Adaptador de Panel B
Panel Adapter B

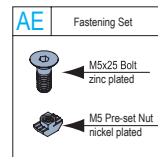
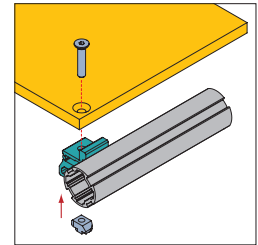
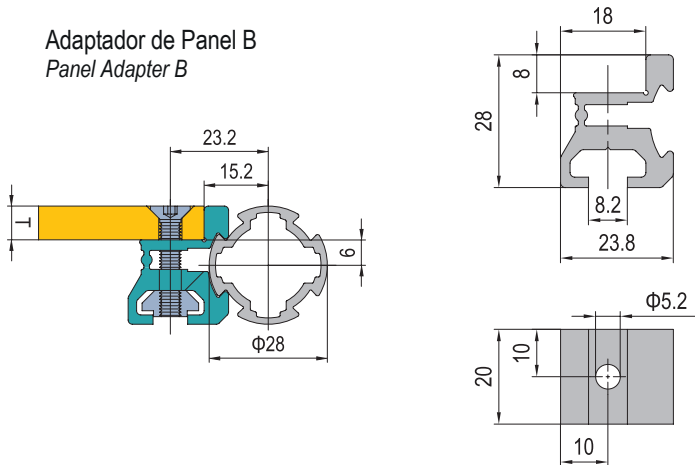

Descripción	Espesor	Fastening Set	Masa (g)	Part No.
Panel Adapter B	T=8mm	1XAE	14	TFS.D28.6.02

Accesorios Adicionales

Additional Accessories

Riel de Rodillos

Flow Roller Track



Material y Color: Ruedas de rodillo-ABS YW (Yellow/Amarillo) GY (Gray/Gris) BK (Black/Negro)
 Estructura del Riel de rodillos: Aleación de Aluminio Anodizado

Los Rieles de Rodillos pueden ser utilizados para montar sistemas de almacenamiento tipo "Carton Flow Rack" donde el producto se alimenta por el extremo trasero, y el picking se realiza por el extremo delantero. Los rodillos son fabricados en PVC de alta calidad que tiene ventajas de bajo coeficiente de fricción, larga vida útil, y resistencia a los ácidos y a la humedad. Se podrán configurar sistemas con varias pistas para repartir la presión que ejerce el bulto a transportar sobre el riel.

Flow Roller Track can be used for "Carton Flow Rack" type storage systems where the product is fed from the rear end, and picking is done from the front end. The rollers are made of high quality PVC which has the advantages of low coefficient of friction, long service life, and resistance to acids and moisture. Systems with several tracks can be configured to distribute the weight.

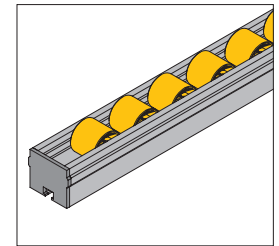
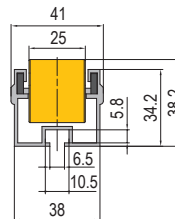
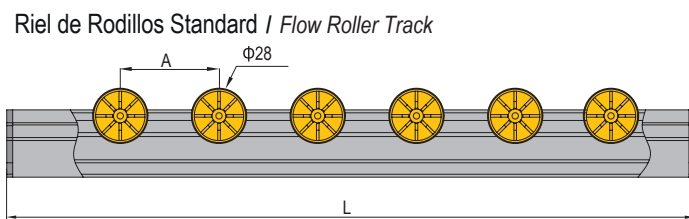

Riel de Rodillos Standard / Flow Roller Track

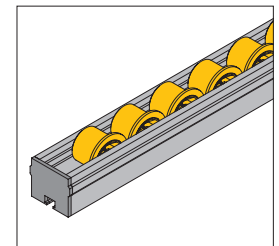
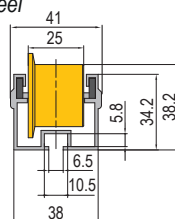
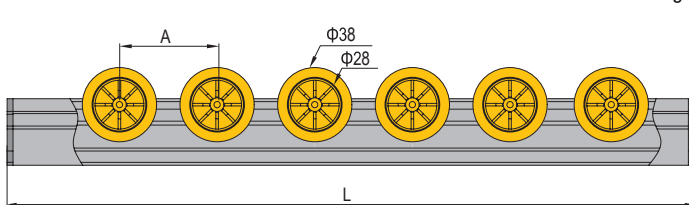

Descripción	A (mm)	Masa (kg)	Longitud	Loading Capacity (kg/m)	Roller Color	Part No.
Flow Roller Track	30	1.74	2000mm/bar	12.5		TFS.D28.8.01.0130.YW
	45	1.7				TFS.D28.8.01.0145.YW
	60	1.61				TFS.D28.8.01.0160.YW
	30	1.74				TFS.D28.8.01.0130.GY
	45	1.7				TFS.D28.8.01.0145.GY
	60	1.61				TFS.D28.8.01.0160.GY
	30	1.74				TFS.D28.8.01.0130.BK
	45	1.7				TFS.D28.8.01.0145.BK
	60	1.61				TFS.D28.8.01.0160.BK

Riel de Rodillos con Ruedas con Pestaña / Flow Roller Track With Flanged Wheel



Descripción	A (mm)	Masa (kg)	Longitud	Loading Capacity (kg/m)	Roller Color	Part No.
Flow Roller Track With Flanged Wheel	45	1.74	2000mm/bar	12.5		TFS.D28.8.01.0245.YW
	60	1.64				TFS.D28.8.01.0260.YW
	75	1.57				TFS.D28.8.01.0275.YW
	45	1.74				TFS.D28.8.01.0245.GY
	60	1.64				TFS.D28.8.01.0260.GY
	75	1.57				TFS.D28.8.01.0270.GY
	45	1.74				TFS.D28.8.01.0245.BK
	60	1.64				TFS.D28.8.01.0260.BK
	75	1.57				TFS.D28.8.01.0270.BK

Accesorios Adicionales
Additional Accessories

Soporte de Riel
Rail Holder

El soporte de riel se sujeta al perfil tubular. Material : Acero zincado.
Rail Holder is attached to the tubular profile. Material: Zinc plated steel.

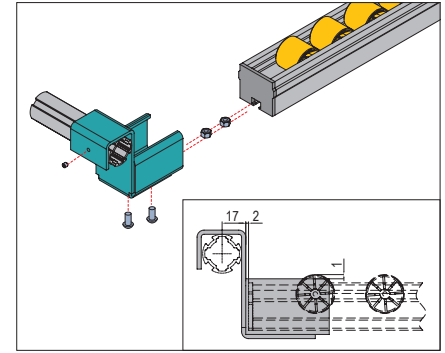

Soporte de Riel Alto
High Rail Holder

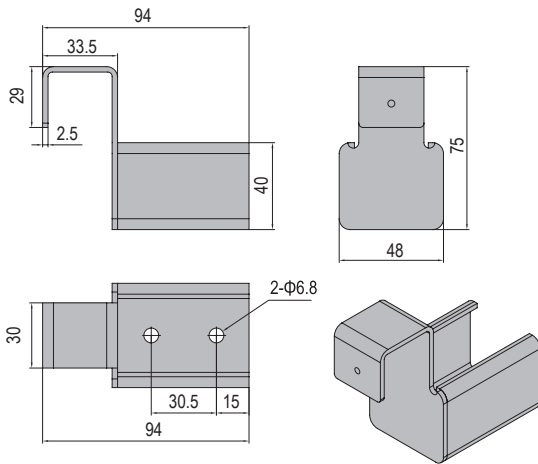

AH	Fastening Set	AI	Fastening Set
	M6x12 Bolt zinc plated		M4 Set Screw stainless steel
	M6 standard Nut zinc plated		

Descripción	Fastening Set	Masa (g)	Part No.
High Rail Holder	2XAH+1XAI	351	TFS.D28.8.02.01

Soporte de Riel Plano
Flat Rail Holder

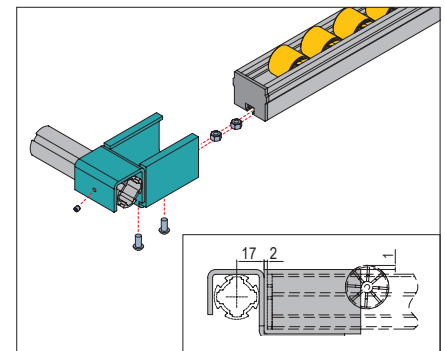
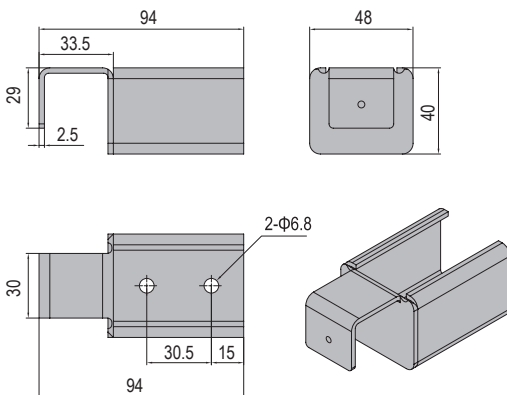

AH	Fastening Set	AI	Fastening Set
	M6x12 Bolt zinc plated		M4 Set Screw stainless steel
	M6 standard Nut zinc plated		

Descripción	Fastening Set	Masa (g)	Part No.
Flat Rail Holder	2XAH+1XAI	342.5	TFS.D28.8.02.02

Accesorios Adicionales
Additional Accessories

Rail Holder
Rail Holder

Rail Holder Hang on profile tubes.
Material : Acero zincado

Soporte de Riel Plano Bilateral / Bilateral Flat Rail Holder

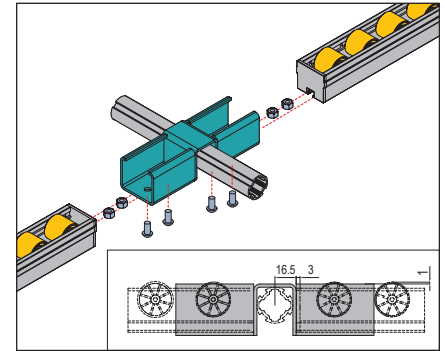
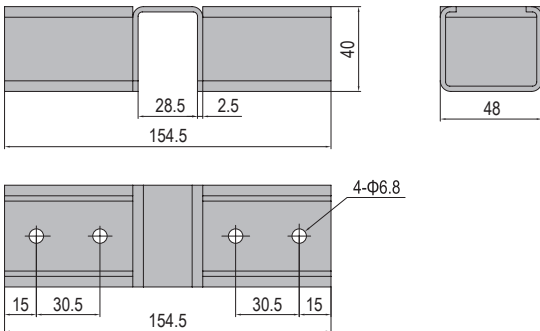

Descripción	Fastening Set	Masa (g)	Part No.
Bilateral Flat Rail Holder	4XAH	355	TFS.D28.8.02.03

Fastening Set
M6x12 Bolt zinc plated
M6 standard Nut zinc plated

Soporte de Riel Transversal / Cross Rail Holder

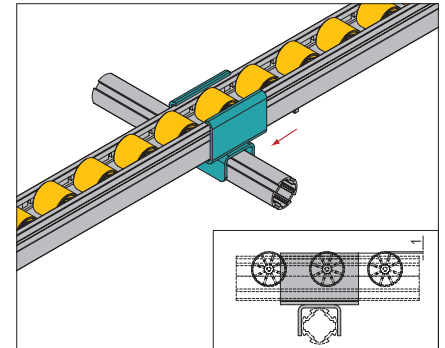
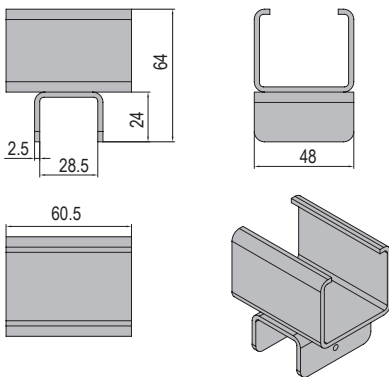

Descripción	Fastening Set	Masa (g)	Part No.
Cross Rail Holder	1xAI	166	TFS.D28.8.02.04

Fastening Set
M4 Set Screw stainless steel

Accesorios Adicionales
Additional Accessories

Adaptador de Perfil
Profile Adapter

El Adaptador de Perfil se usa con el conector D28 para unir el Perfil Tubular con el Perfil de Aluminio.
The Profile Adapter is used with the D28 connector to join the Tubular Profile to the Aluminum Profile.

Material: Fundición de Aluminio / Aluminium Casting

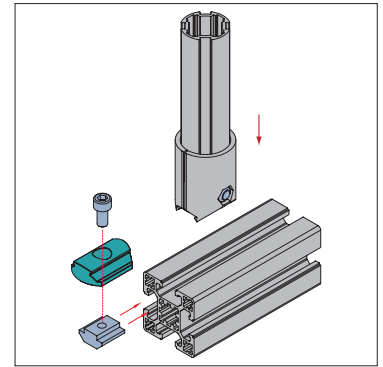
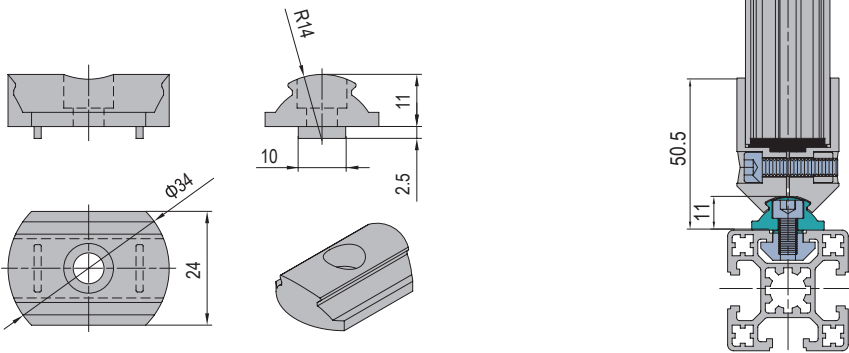

Descripción	Fastening Set	Masa (g)	Part No.
Profile Adapter	1XCO	36	TFS.D28.8.03.01
	1XCP	36	TFS.D28.8.03.02

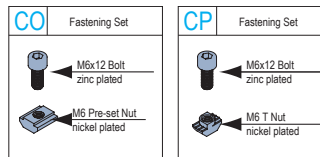

Adaptador a Perfil Tubular
Tube Adapter

Material: Aluminio Fundido / Aluminium Casting

El Adaptador de Perfil Tubular se fija mediante un Conector D28 para unir tubos al perfil tubular.
The Tube Adapter is fixed by a D28 Connector to join tubes to the tubular profile.

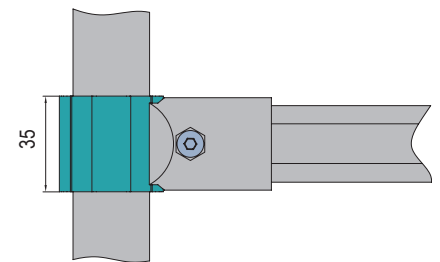
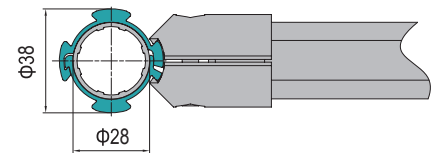
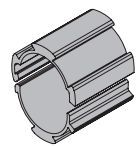

Descripción	Masa (g)	Part No.
Tube Adapter	28.3	TFS.D28.8.03.03

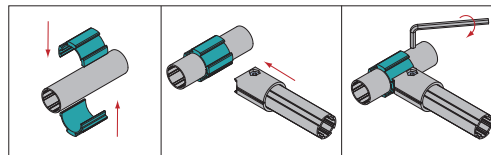

Accesorios Adicionales
Additional Accessories

Adaptador Deslizante D28
Slide Adapter D28

Material: Aluminio Fundido / *Aluminium Casting*

El Adaptador Deslizante D28 se usa con un Conector D28 para una unión transversal entre dos perfiles tubulares, permitiendo la movilidad a lo largo del perfil.

Slide Adapter D28 is used with a D28 Connector for a transverse connection between two tubular profiles, allowing mobility all along

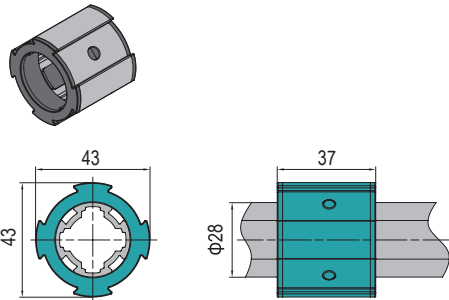
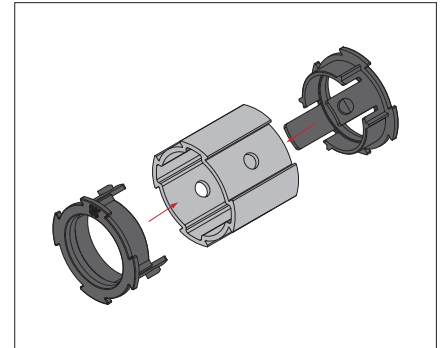

Descripción	Masa (g)	Part No.
Slide Adapter D28	31.5	TFS.D28.8.04

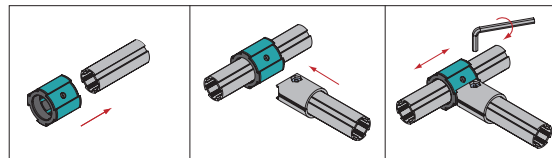

Perfil de Suspensión
Suspension Profile

Material: Aluminio Extruido / *Extruded Aluminium*

El Perfil de Suspensión se usa para colgar cajas de materiales, sujetándolo al Perfil Tubular D28 con un Conector Paralelo A.

The Suspension Profile is used to hang boxes, attaching it to the D28 Tubular Profile with a Parallel Connector A.

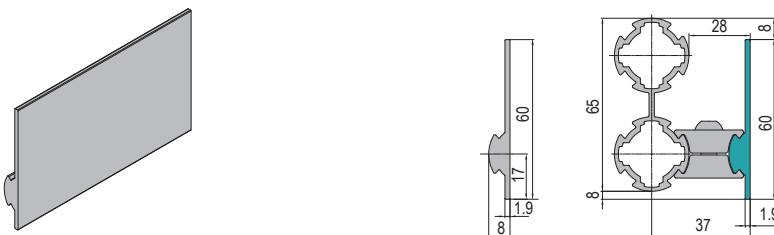
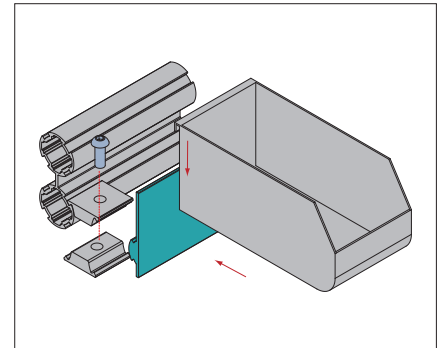

Descripción	Masa (kg/m)	Longitud L(mm)	Part No.
Suspension Profile	0.51	0-5800	TFS.D28.8.05

Nota: El largo puede ser personalizado de acuerdo a los requerimientos del cliente (Lmax. =5800mm).

Note: The length can be customized according to client's requirements (Lmax. =5800mm).

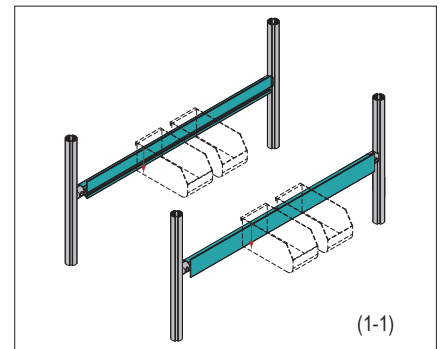

⚠ Las cajas de materiales se pueden sujetar directamente al Perfil Tubular D28 usando el Perfil SW D28 o el Perfil DW D28, ver Fig (1-1).



Sistema de Ensamble Modular
Modular Assembly System

MAS



Sistema de Transportadores Modulares
Modular Conveyor System

MCS



Sistema de Plataformas y Escaleras
Stair and Platform System

SPS



Sistema de Cerramientos de Seguridad
Machine Guard System

MGS



Sistema de Estructuras Tubulares
Tubular Framing System

TFS



Alutipo SRL

Web: www.alutipo.com

Email: info@alutipo.com

Tubular Framing System