

# Stair and Platform System



Sistema de Plataformas y Escaleras  
*Stair and Platform System*





Sistema de Plataformas y Escaleras  
*Stair and Platform System*

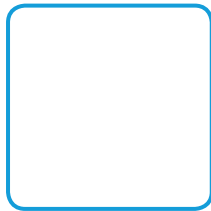
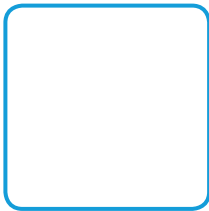
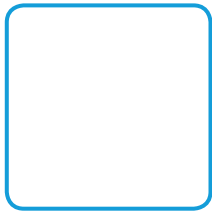
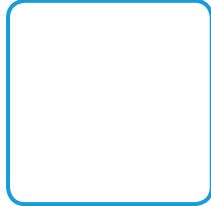
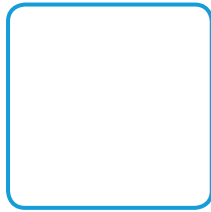

Sistema de Plataformas y Escaleras



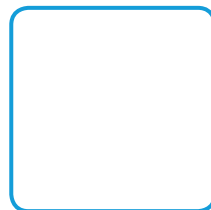
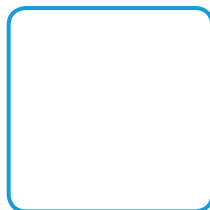
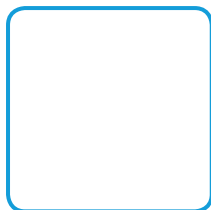
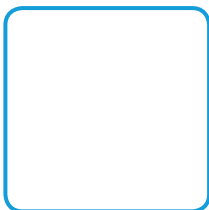
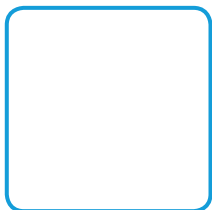
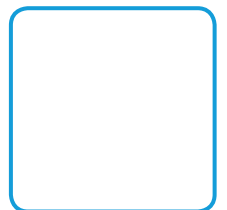
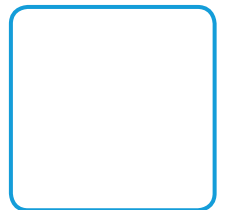
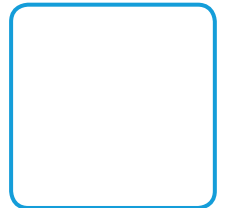

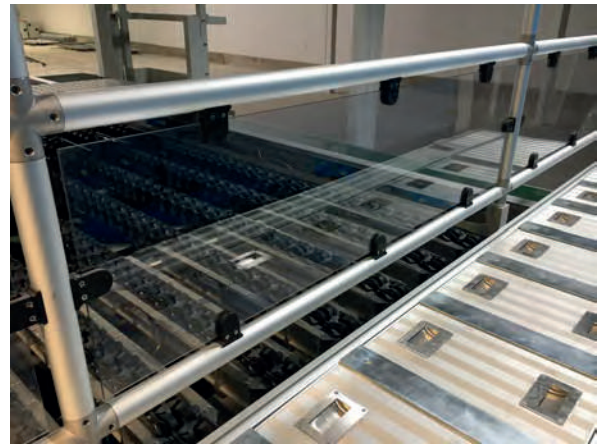
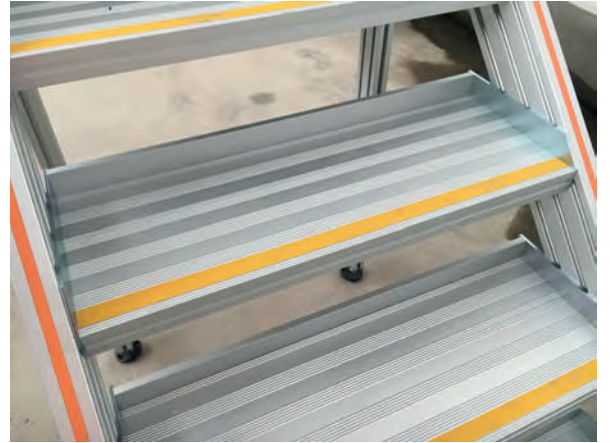

























*Stair and Platform System*





Indice de Productos / Product Index



<p>Aluminum Tube <math>\Phi 40 \times 3</math></p>  <p>Page 02</p>	<p>Step Profile 40x100</p>  <p>Page 02</p>	<p>Step Profile 40x150</p>  <p>Page 02</p>	<p>Step Profile 40x250</p>  <p>Page 02</p>	<p>Strut Profile PG40 40x120 8 slots</p>  <p>Page 03</p>
<p>Strut Profile PG40 40x160 10 slots</p>  <p>Page 03</p>	<p>V Connector</p>  <p>Page 04</p>	<p>L Connector</p>  <p>Page 04</p>	<p>T Connector</p>  <p>Page 04</p>	<p>45°L Connector (Left)</p>  <p>Page 05</p>
<p>45°L Connector (Right)</p>  <p>Page 05</p>	<p>45°T Connector (Left)</p>  <p>Page 05</p>	<p>45°T Connector (Right)</p>  <p>Page 06</p>	<p>45°Y Connector (Left)</p>  <p>Page 06</p>	<p>45°Y Connector (Right)</p>  <p>Page 06</p>
<p>X Connector</p>  <p>Page 07</p>	<p>135° Connector</p>  <p>Page 07</p>	<p>135°L Connector</p>  <p>Page 07</p>	<p>90°L Connector</p>  <p>Page 08</p>	<p>90°T Connector</p>  <p>Page 08</p>
<p>Cross Connector</p>  <p>Page 08</p>	<p>Round Base</p>  <p>Page 09</p>	<p>T Base</p>  <p>Page 09</p>	<p>Side Base</p>  <p>Page 10</p>	<p>Stair Joint</p>  <p>Page 11</p>
<p>Clamp</p>  <p>Page 12</p>	<p>Angle Plate-40x160</p>  <p>Page 13</p>	<p>Angle Plate-40x120</p>  <p>Page 13</p>	<p>Base Plate</p>  <p>Page 14</p>	<p>Pivot Foot</p>  <p>Page 15</p>
<p>Base Angle</p>  <p>Page 16</p>				

## Sistemas de Escaleras y Plataformas Stair and Platform System (SPS)

Los sistemas SPS son adecuados para aplicaciones interiores o exteriores desde un simple sistema de barandas a un complejo sistema de escaleras y plataformas de trabajo. Las conexiones se realizan sin esfuerzo, simplemente asegurando el apriete de los diferentes accesorios de sujeción.

*The SPS is suitable for many indoor and outdoor applications from a simple guardrailing to a large stair and work platform system. Sections are connected without effort by simply tightening clamping screws.*

- Normas de diseño / *Design Standards:*
  - Australian and NZ AS 1657-2013 Fixed platforms (standard);
  - EN-ISO 14122 (opcional / *optional*);
  - Otra según requerimiento del cliente / *Other as per customer request.*
- Especificación básica del producto / *Basic Product Spec:*
  - Profiles: T-Slot Extruded Aluminium Profile 6063-T5 with anodizing layer  $\geq 11$  microns;
  - Profile Finishing: Etching finishing (provides uniform surface; hides extrusion lines and imperfections);
  - Accessories: Die Cast Aluminum (standard), Die Cast Aluminum with Chemical Oxidation Process (optional);
  - Sheetmetal Accessories: Zinc Plated Steel (standard), SS (optional);
  - Fasteners: Nickel Plated Steel (standard), SS (optional).
- Sobrecarga de diseño / *Design Load Capacity:*
  - 250 kg/m<sup>2</sup> (standard);
  - Otra según requerimiento del cliente / *Other as per customer request.*
- Distancia entre apoyos máxima / *Max unsupported length:*
  - Hasta 8 metros para perfil PG80280 / *Up to 8 metres for PG80280 profile;*
  - Otra según requerimiento del cliente / *Other as per customer request.*

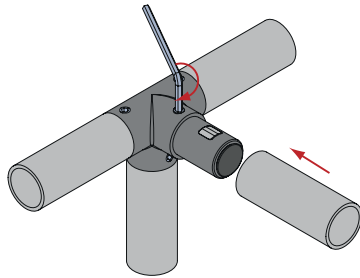

Los conectores de baranda poseen un sistema interno especial para fijar los tubos.  
*Handrail connectors have a special internal locking system to fix the handrail tubes.*

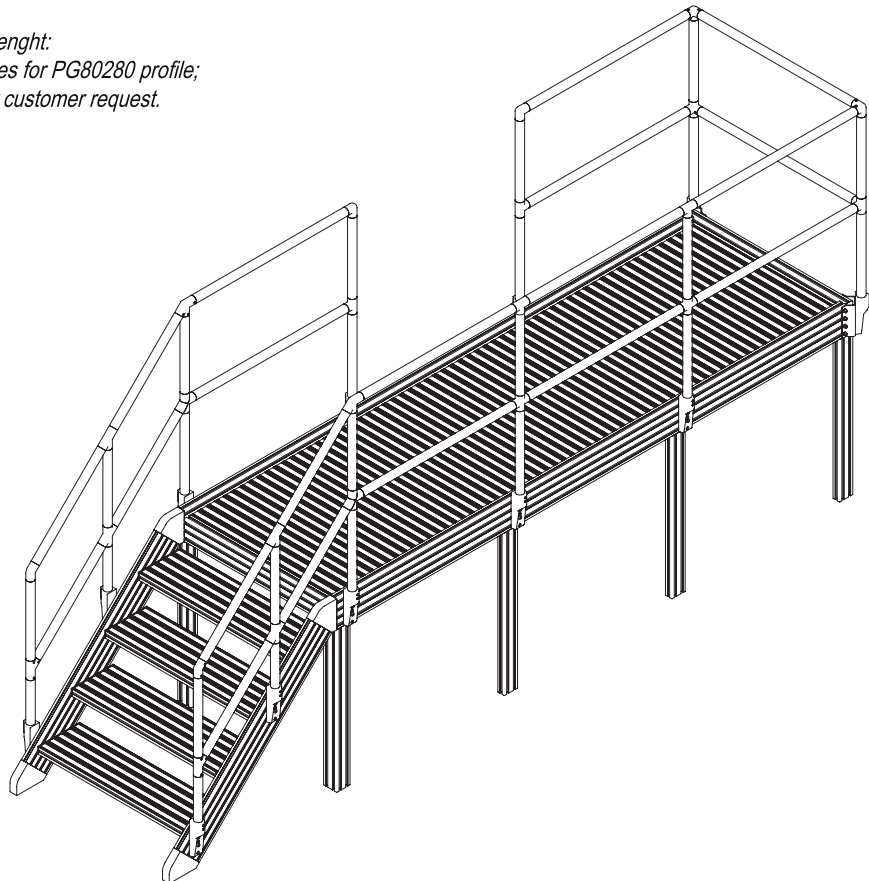

Tubo de Aluminio  $\Phi 40 \times 3$   
 Aluminum Tube  $\Phi 40 \times 3$

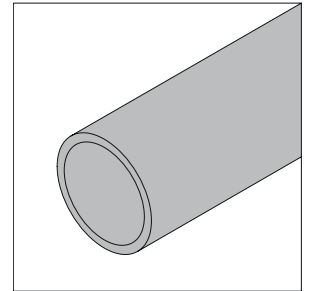
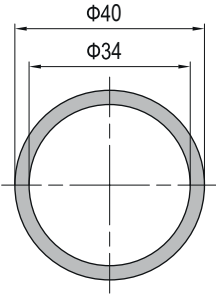

Perfil de Piso 40x100  
 Step Profile 40x100

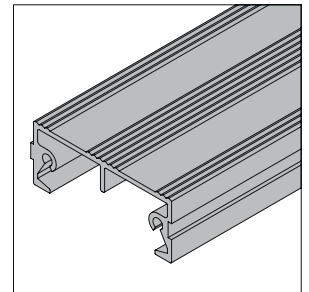
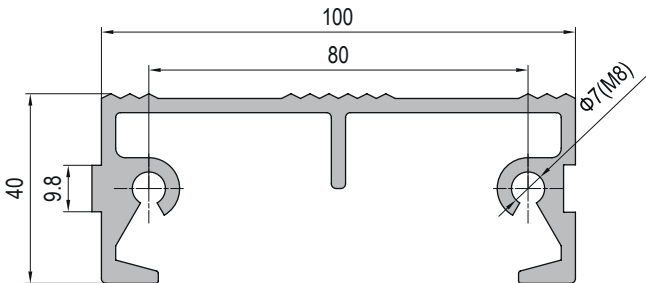

Perfil de Piso 40x150  
 Step Profile 40x150

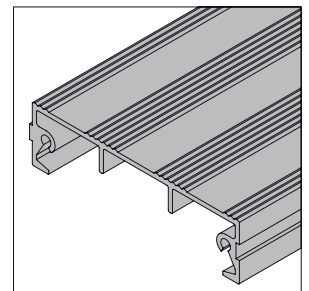
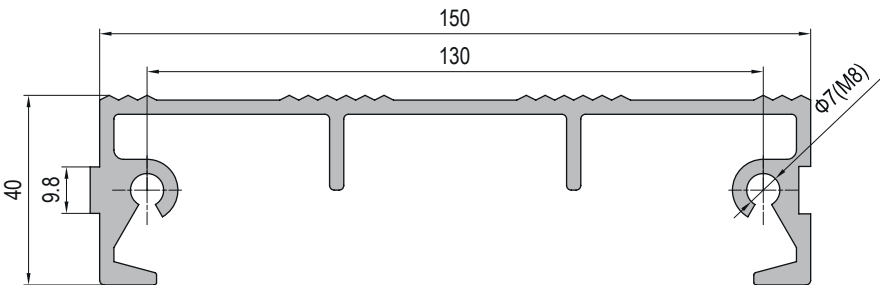

Descripción	Momento Inercia $I_x(\text{cm}^4)$	Momento Inercia $I_y(\text{cm}^4)$	Módulo Resistente $W_x(\text{cm}^3)$	Módulo Resistente $W_y(\text{cm}^3)$	Masa (kg/m)	Part No.
Aluminum Tube $\Phi 40 \times 3$	6.0	6.0	3.0	3.0	1.0	SPS.AT40.03
Step Profile 40x100	13.2	128.6	6.6	25.7	2.4	SPS.SP40.100
Step Profile 40x150	15.4	342.0	7.7	45.6	2.9	SPS.SP40.150
Step Profile 40x250	21.5	120.1	10.7	96.0	4.5	SPS.SP40.250

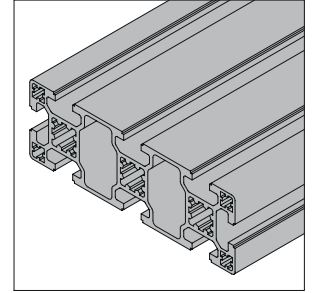
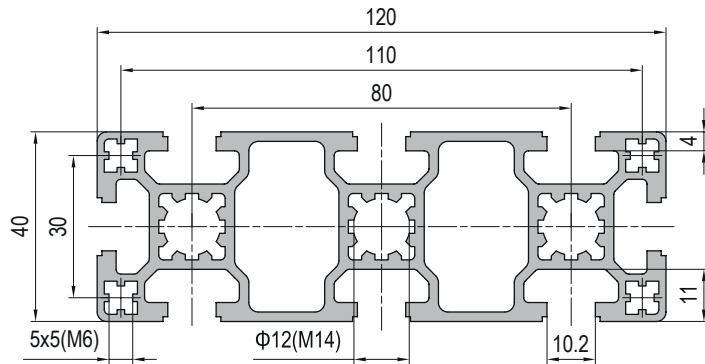
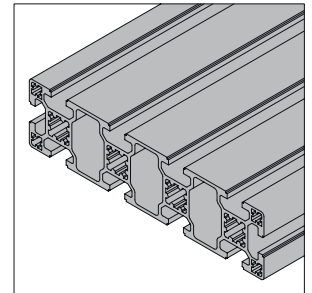
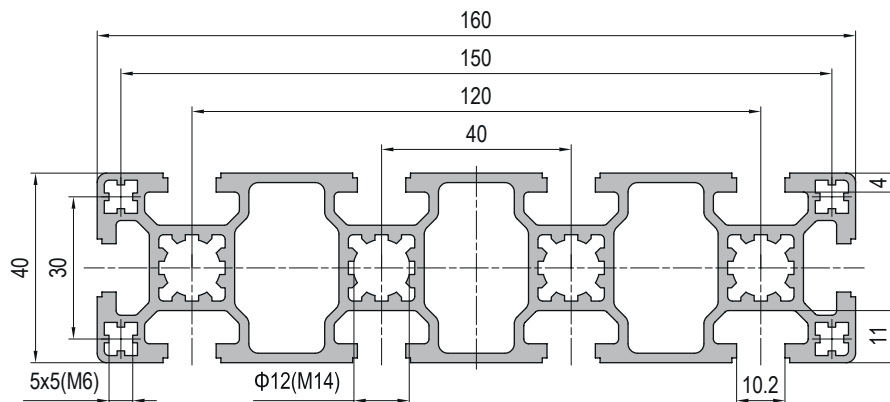
**Perfil de Aluminio PG40 40x120 8 ranuras**
*Strut Profile PG40 40x120 8 slots*

**Perfil de Aluminio PG40 40x160 10 ranuras**
*Strut Profile PG40 40x160 10 slots*

Descripción	Momento Inercia $I_x(\text{cm}^4)$	Momento Inercia $I_y(\text{cm}^4)$	Módulo Resistente $W_x(\text{cm}^3)$	Módulo Resistente $W_y(\text{cm}^3)$	Masa (kg/m)	Part No.
Strut Profile PG40x120 8 slots	24.1	194.8	12.1	32.5	3.8	1.11.40.040120.08
Strut Profile PG40x160 10 slots	31.6	435.7	15.8	54.5	4.8	1.11.40.040160.10

\* Otros tamaños de perfil según requerimiento de carga / Other profile sizes as per load requirements



**Conector tipo V**

V-Connector

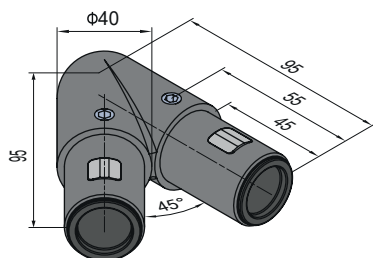

Descripción	Masa (g)	Part No.
V-Connector	550	SPS.JC40.V

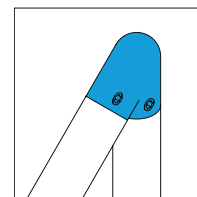
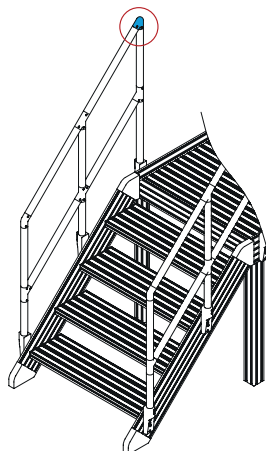

**Conector tipo L**

L-Connector

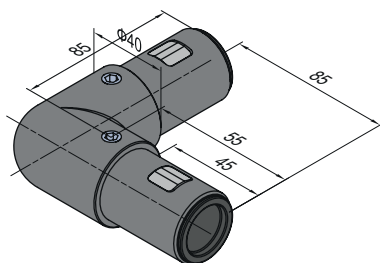

Descripción	Masa (g)	Part No.
L-Connector	518	SPS.JC40.L

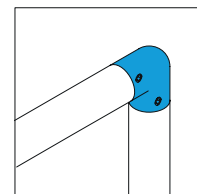
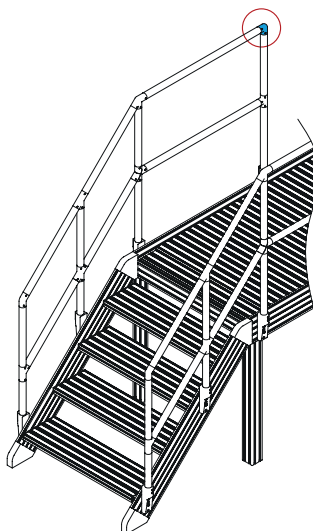

**Conector tipo T**

T-Connector

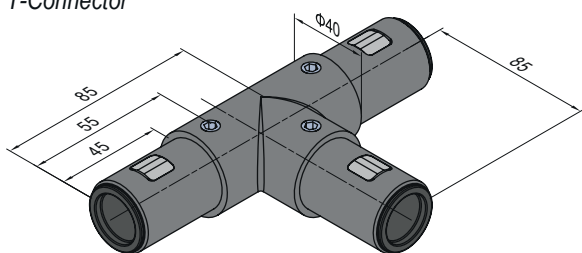

Descripción	Masa (g)	Part No.
T-Connector	728	SPS.JC40.T

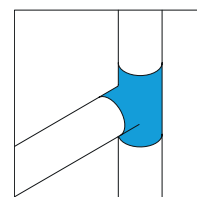
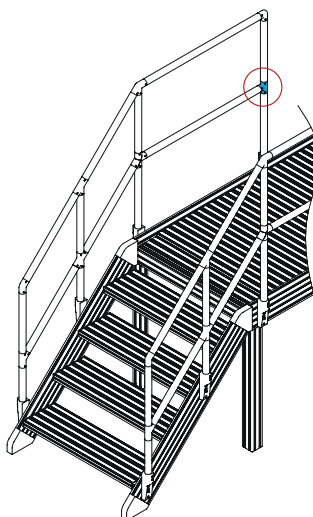

Conector tipo 45°L (Izquierdo)  
45°L-Connector (Left)

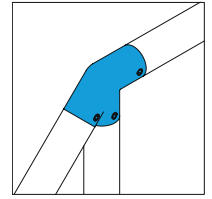
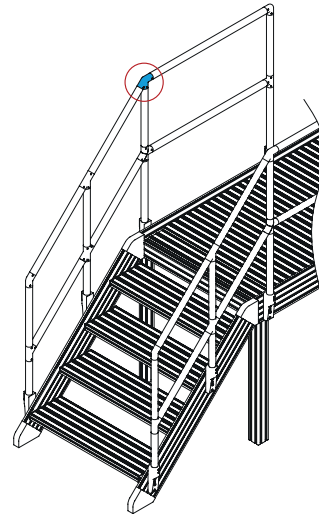
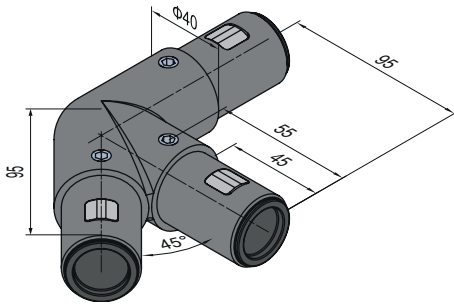

Descripción	Masa (g)	Part No.
45°L-Connector (Left)	728	SPS.JC40.A45L.L

Conector tipo 45°L (Derecho)  
45°L-Connector (Right)

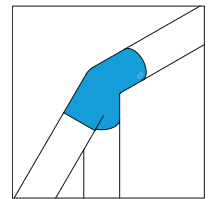
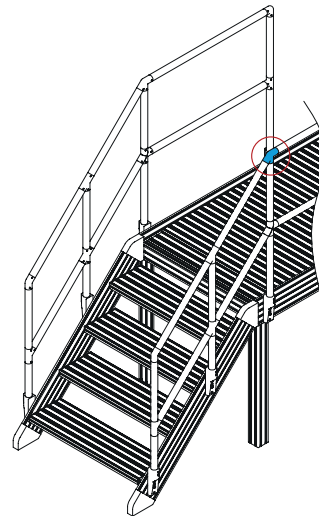
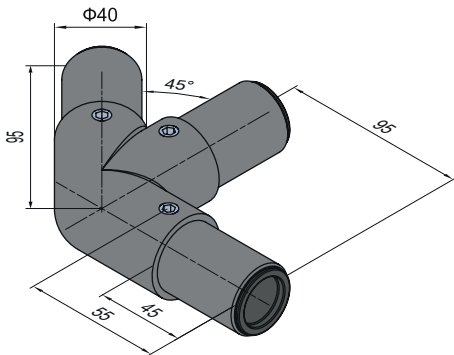

Descripción	Masa (g)	Part No.
45°L-Connector (Right)	728	SPS.JC40.A45L.R

Conector tipo 45°T (Izquierdo)  
45°T-Connector (Left)

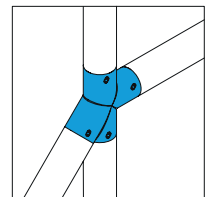
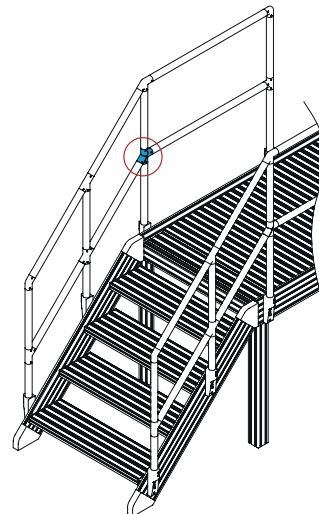
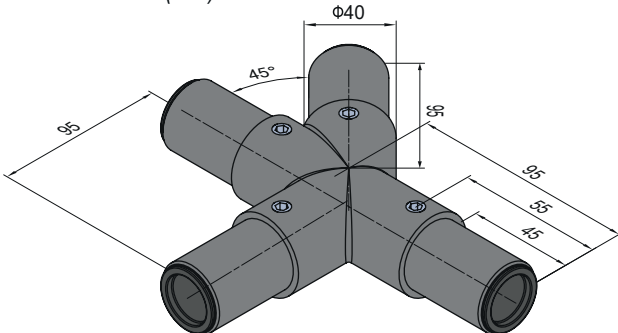

Descripción	Masa (g)	Part No.
45°T-Connector (Left)	1037	SPS.JC40.A45T.L

Conector tipo 45°T (Derecho)  
45°T-Connector (Right)

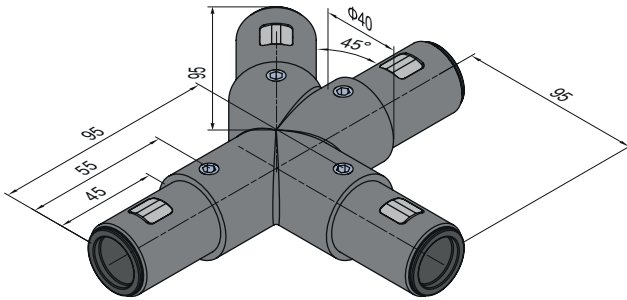

Descripción	Masa (g)	Part No.
45°T-Connector (Right)	1037	SPS.JC40.A45T.R

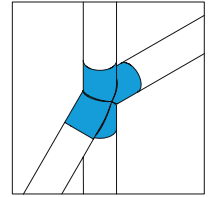
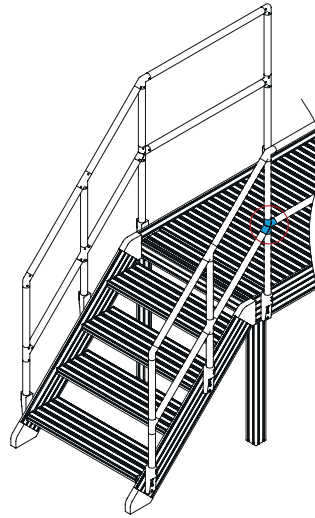

Conector tipo 45°Y (Izquierdo)  
45°Y-Connector (Left)

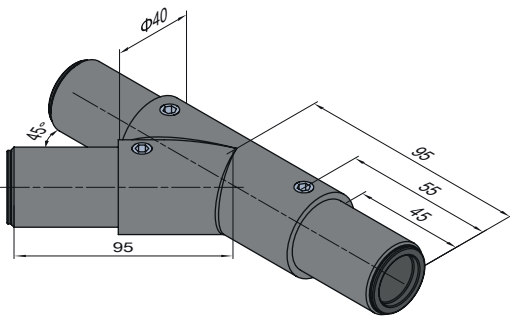

Descripción	Masa (g)	Part No.
45°Y-Connector (Left)	801	SPS.JC40.A45Y.L

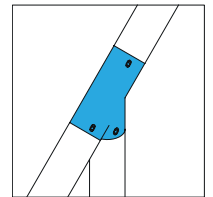
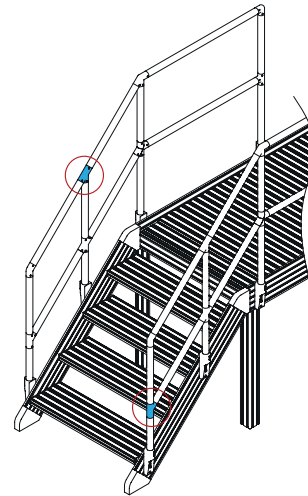

Conector tipo 45°Y (Derecho)  
45°Y-Connector (Right)

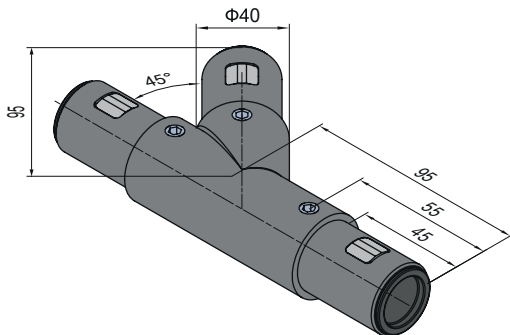

Descripción	Masa (g)	Part No.
45°Y-Connector (Right)	801	SPS.JC40.A45Y.R

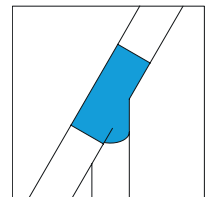
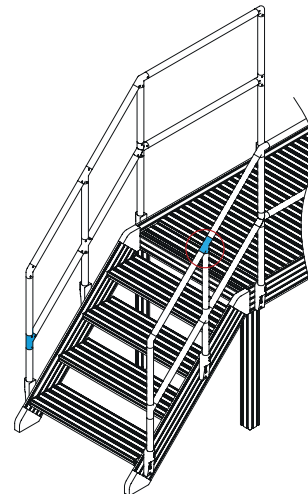

Conector tipo X  
X-Connector

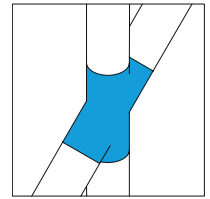
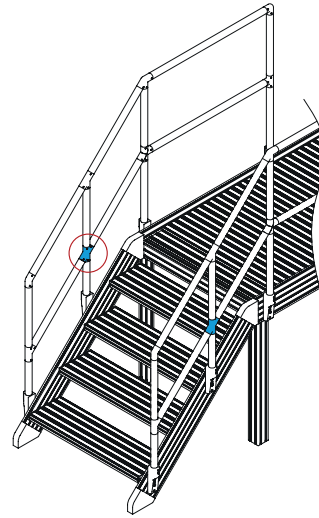
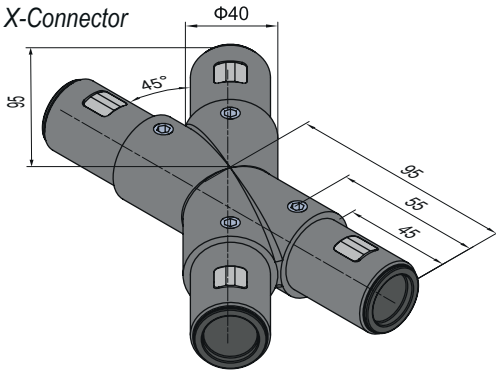

Descripción	Masa (g)	Part No.
X-Connector	1012	SPS.JC40.X

Conector tipo 135°  
135°-Connector

\* Conector tipo 120° y 150° disponible  
120° and 150°-Connector available

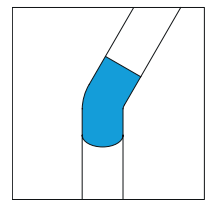
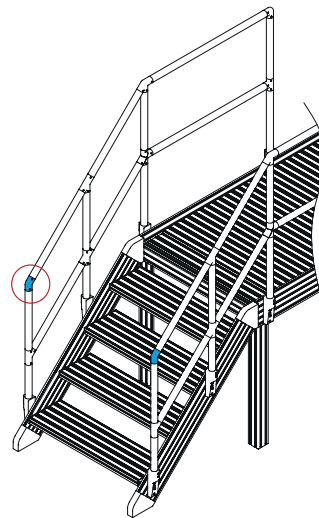
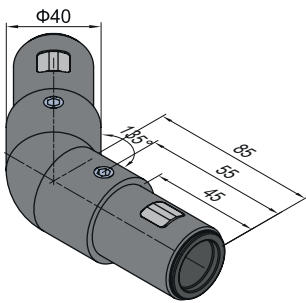

Descripción	Masa (g)	Part No.
135°-Connector	521	SPS.JC40.A135

Conector tipo 135°L  
135°L-Connector

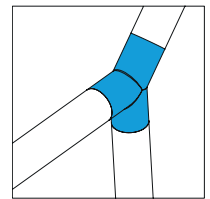
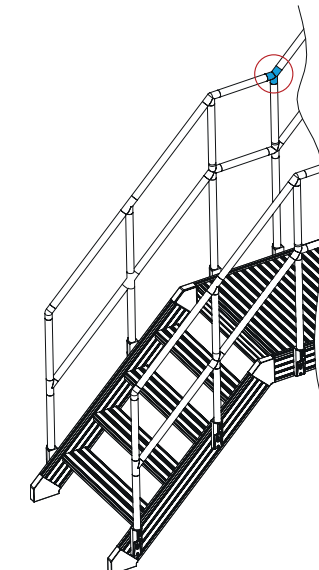
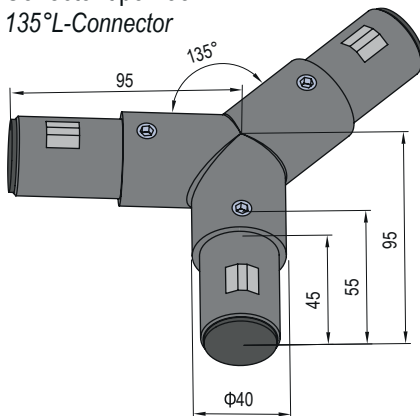

Descripción	Masa (g)	Part No.
135°L-Connector	814	SPS.JC40.A135L

Conector tipo 90°L  
90°L-Connector

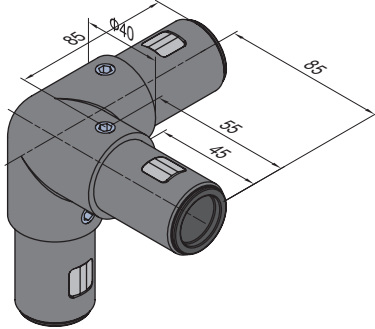

Descripción	Masa (g)	Part No.
90°L-Connector	723	SPS.JC40.A90L

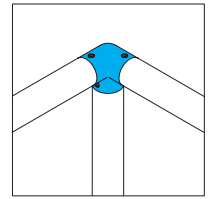
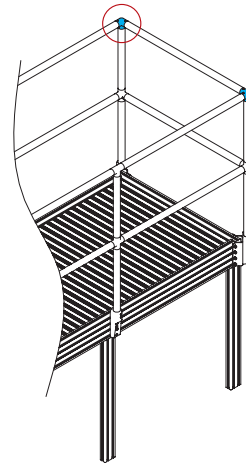

Conector tipo 90°T  
90°T-Connector

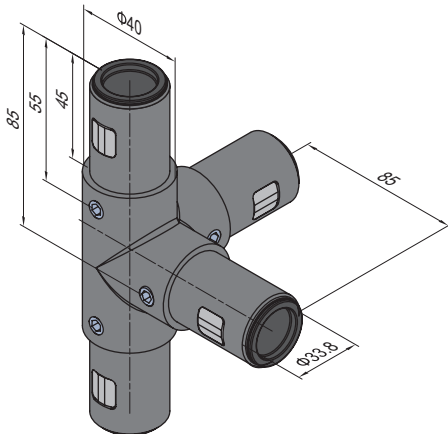

Descripción	Masa (g)	Part No.
90°T-Connector	934	SPS.JC40.A90T

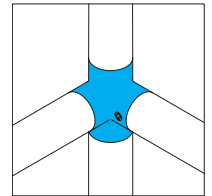
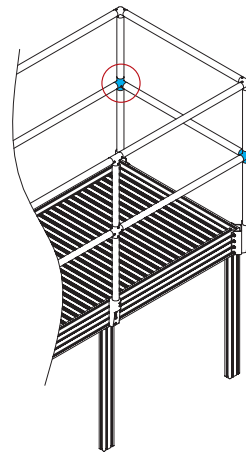

Conector tipo Cruz  
Cross Connector

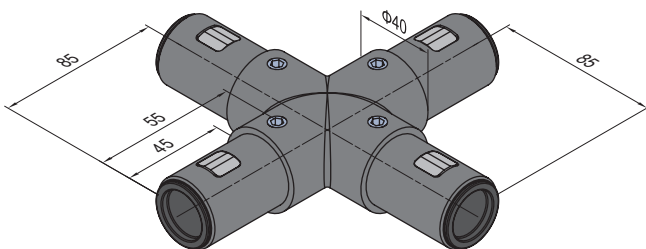

Descripción	Masa (g)	Part No.
Cross Connector	932	SPS.JC40.C

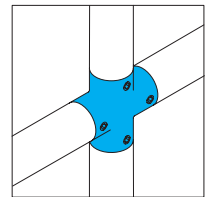
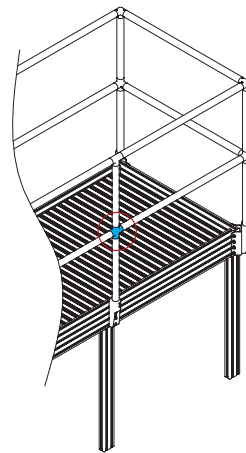

**Base Redonda**  
Round Base

Material: Aluminio fundido / superficie pulida  
Die Cast Aluminium / Polish finish surface

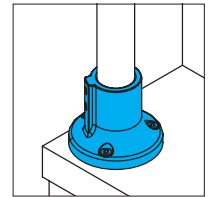
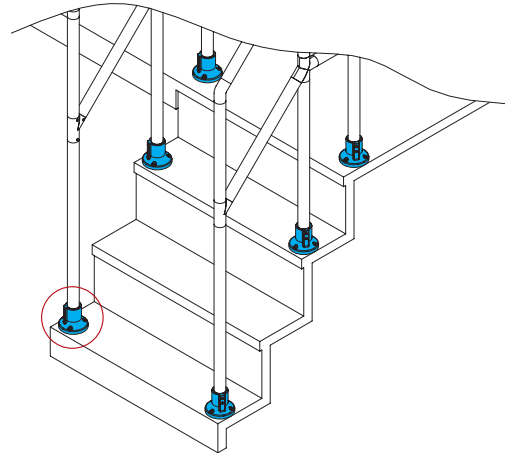
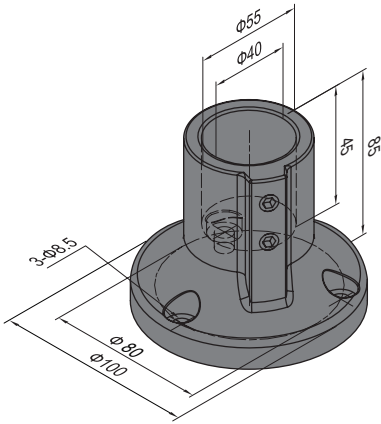

Descripción	Fastening Set	Masa (g)	Part No.
Round Base	3xCT	635	SPS.BA40.R

CT	Fastening Set
	M8x20 Bolt zinc plated
	M8 Spring Washer zinc plated

**Base tipo T**  
T Base

Material: Aluminio fundido / superficie pulida  
Die Cast Aluminium / Polish finish surface

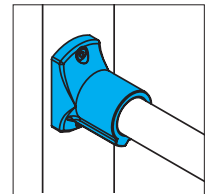
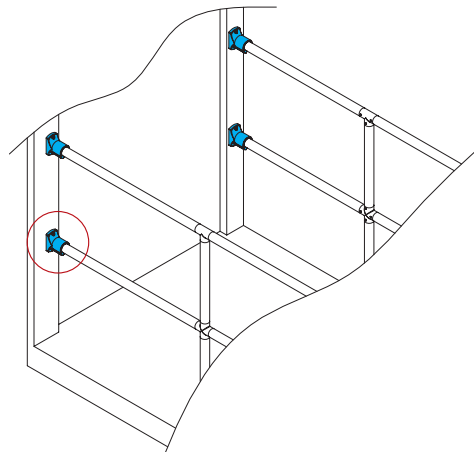
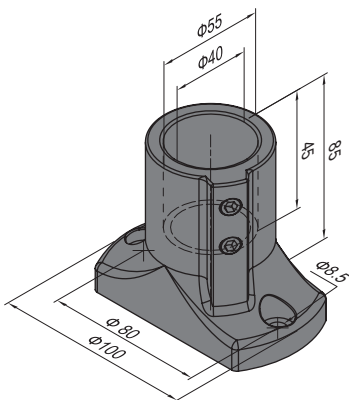

Descripción	Fastening Set	Masa (g)	Part No.
T Base	2xCT	491	SPS.BA40.T

CT	Fastening Set
	M8x20 Bolt zinc plated
	M8 Spring Washer zinc plated

**Base Lateral**  
Side Base

Material: Aluminio fundido / superficie pulida  
Die Cast Aluminium / Polish finish surface

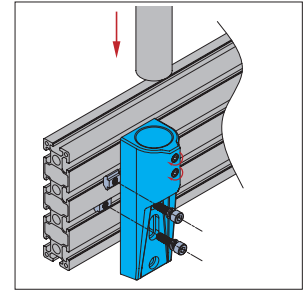
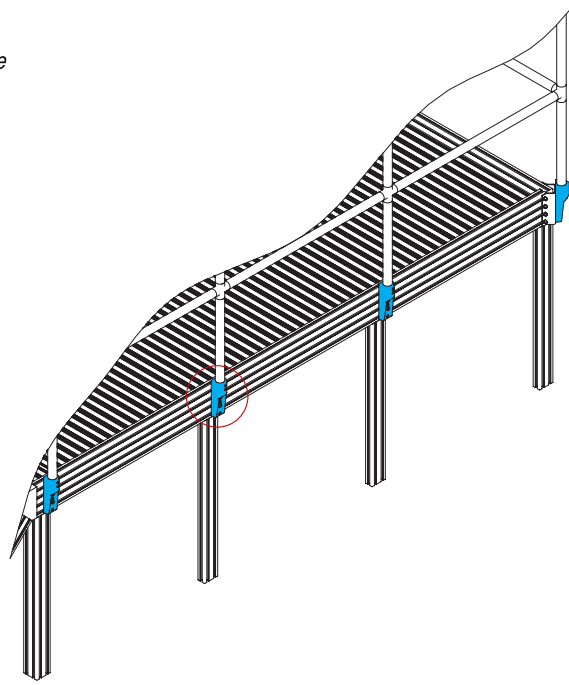
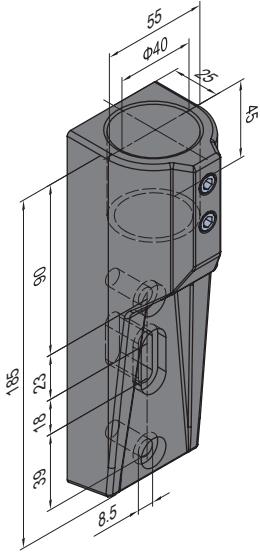

Descripción	Fastening Set	Masa (g)	Part No.
Side Base (pcs)	2xCR	781	SPS.BA.S
Side Base (set)	2xCS	813	SPS.BA.S.ST

CR	Fastening Set
	M8x30 Bolt zinc plated
	M8 Spring Washer zinc plated

CS	Fastening Set
	M8x30 Bolt zinc plated
	M8 Spring Washer zinc plated
	M8 Pre-set Nut nickel plated

**Unión de Escalera 45°**  
45° Stair Joint

Material: Aluminio fundido / superficie pulida  
Die Cast Aluminium / Polish finish surface

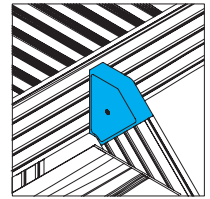
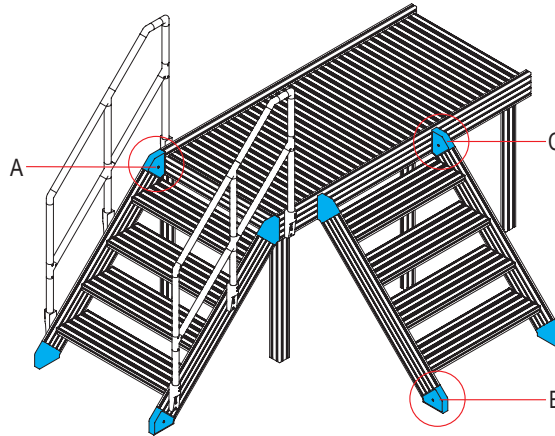
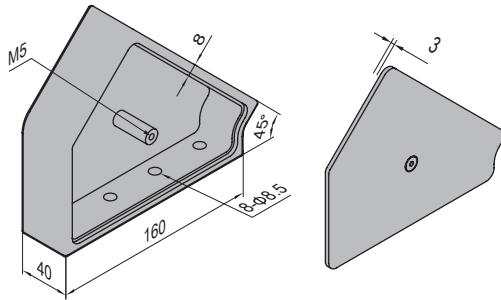

Descripción	Tipo de Unión	Fastening Set	Masa (g)	Part No.
Stair Joint-A	A	8xHM	1044	SPS.SJ40.45A
Stair Joint-B	B	4xHM	932	SPS.SJ40.45B
Stair Joint-C	C	4xHM+4xHR	1068	SPS.SJ40.45C

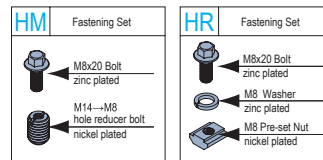

\* Otros piezas de unión para escaleras de 30° y 60° disponibles / Other stair joint units for 30° and 60° stairs available

**Platina Lateral de Escalera**  
Stair Side Plate

Material: Aluminio / Aluminium

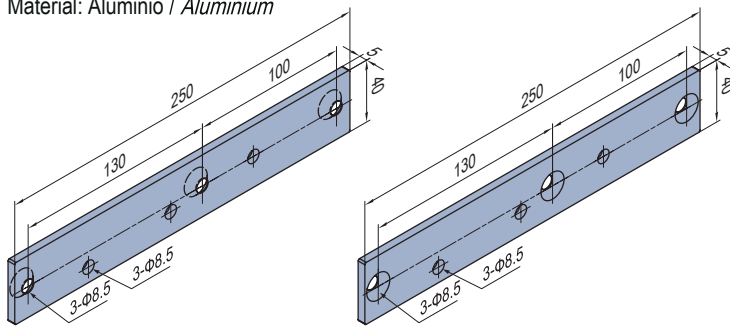

Izquierda / Left

Derecha / Right

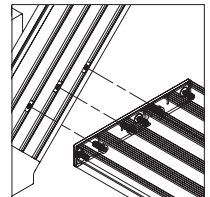
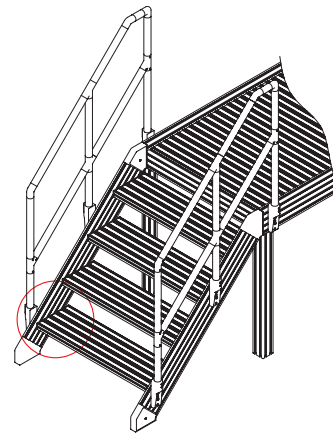

Descripción	Fastening Set	Masa (g)	Part No.
Stair Side Plate (set)	6xGA+6xHN	492	SPS.SSP40

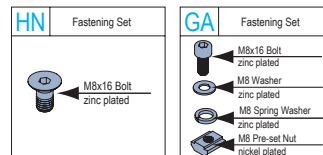

\* Otros diseños de platinas laterales para escaleras de 30° y 60° disponibles / Other stair side plates for 30° and 60° stairs available



**Abrazadera tipo A**  
*Clamp A*

Material: Aluminio / Aluminium

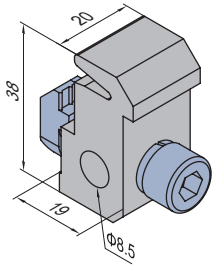

HQ	Fastening Set
	M8x30 Bolt zinc plated
	M8 Spring Washer zinc plated
	M8 T Nut nickel plated

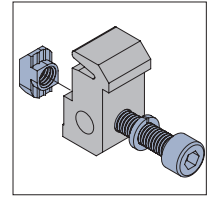
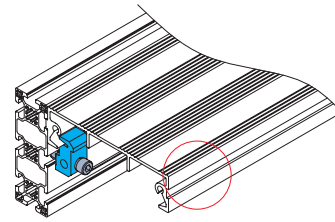

Descripción	Fastening Set	Masa (g)	Part No.
Clamp Type A	1xHQ	52	SPS.CL40.A

**Abrazadera tipo B / C**  
*Clamp B / C*

Material: Aluminio / Aluminium

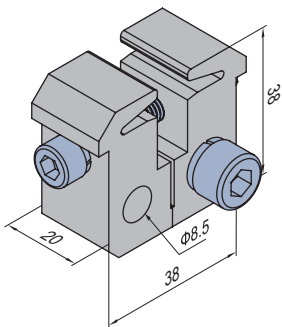

PD	Fastening Set	HQ	Fastening Set
	M6x45 Bolt zinc plated		M8x30 Bolt zinc plated
	M6 Spring Washer zinc plated		M8 Spring Washer zinc plated
			M8 T Nut nickel plated

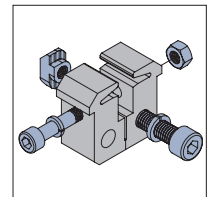
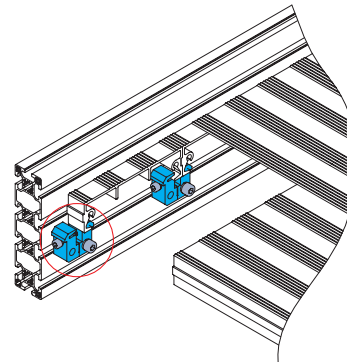

Descripción	Fastening Set	Masa (g)	Part No.
Clamp Type B	1xPD+1xHQ	70	SPS.CL40.B
Clamp Type C	1xPD	68.5	SPS.CL40.C

Platina tipo Angulo 40x160  
Angle Plate 40x160

Material: Perfil de Aluminio Extruido / Extruded Aluminium Profile

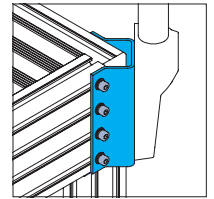
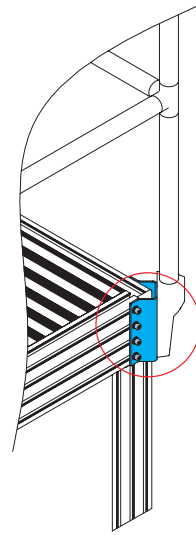
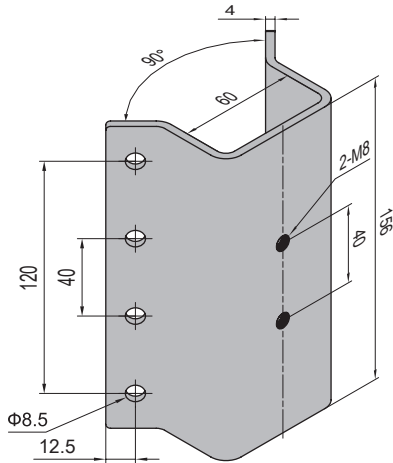

Descripción	Fastening Set	Masa (g)	Part No.
Angle Plate	8xGA	920	SPS.AP40.160

GA	Fastening Set
	MBx16 Bolt zinc plated
	M8 Washer zinc plated
	M8 Spring Washer zinc plated
	M8 Pre-set Nut nickel plated

Platina tipo Angulo 40x120  
Angle Plate 40x120

Material: Perfil de Aluminio Extruido / Extruded Aluminium Profile

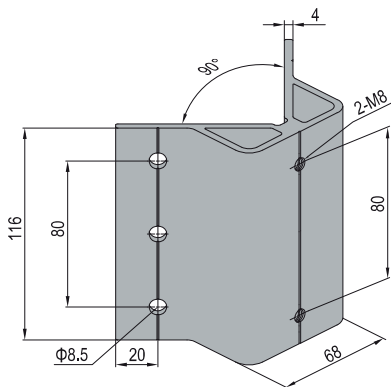

Descripción	Fastening Set	Masa (g)	Part No.
Angle Plate	6xGA	504	SPS.AP40.120

GA	Fastening Set
	MBx16 Bolt zinc plated
	M8 Washer zinc plated
	M8 Spring Washer zinc plated
	M8 Pre-set Nut nickel plated

Elementos de Apoyo  
Floor Elements

Platina Base  
Base Plate

La Platina Base permite fijar las patas de apoyo de la plataforma al suelo mediante la utilización de tacos de expansión.  
Base Plate is used to anchor the platform stand supports to the floor using expansion bolts.

Material y Color: Acero al carbono con terminación de pintura electrostática negro  
Mild steel with powder coating black

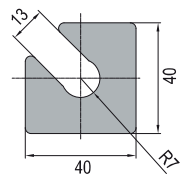
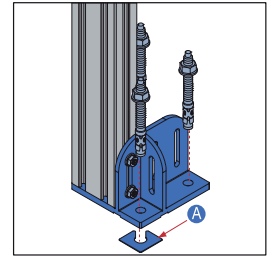

Base Plate Gasket

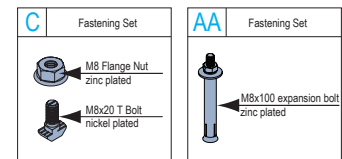
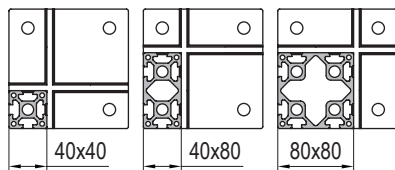
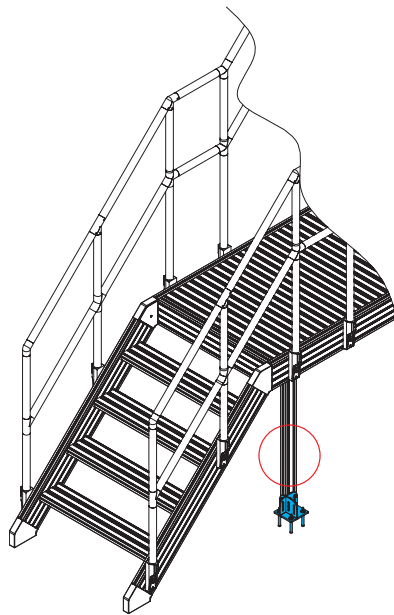
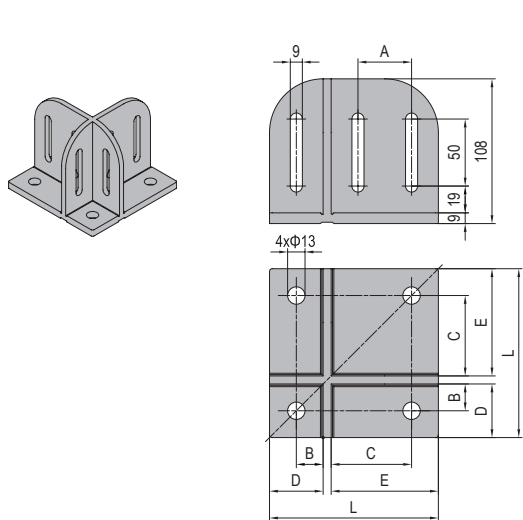

Descripción	L (mm)	A (mm)	B (mm)	C (mm)	D (mm)	E (mm)	Fastening Set	Masa (g)	Part No.
Base Plate-4080 (pcs)								1930	5.11.4080
Base Plate-4080 (set A)	126	40	20	60	40	80	4x <b>C</b> +3x <b>AA</b>	2240	5.11.4080.STA
Base Plate-4080 (set B)							6x <b>C</b> +3x <b>AA</b>	2290	5.11.4080.STB
Base Plate-4080 (set C)							8x <b>C</b> +3x <b>AA</b>	2340	5.11.4080.STC

## Elementos de Apoyo Floor Elements

### Pata tipo Pivot Pivot Foot

La Pata tipo Pivot permite apoyar la estructura en zonas que requieren un ajuste gradual de altura. El pequeño ángulo de rotación absorbe las irregularidades del suelo. La conexión entre la base y la varilla roscada se puede desarmar mediante el uso de una herramienta.

*The Pivot Foot is used to support the structure where gradual height adjustment is needed. The small swivel angle can absorb the slope of uneven floor. The connection between the pivot base and the spindle can be released with a tool.*

Material: Acero al carbono zincado / Acero inoxidable.

*Zinc Plated Mild Steel / Stainless Steel.*

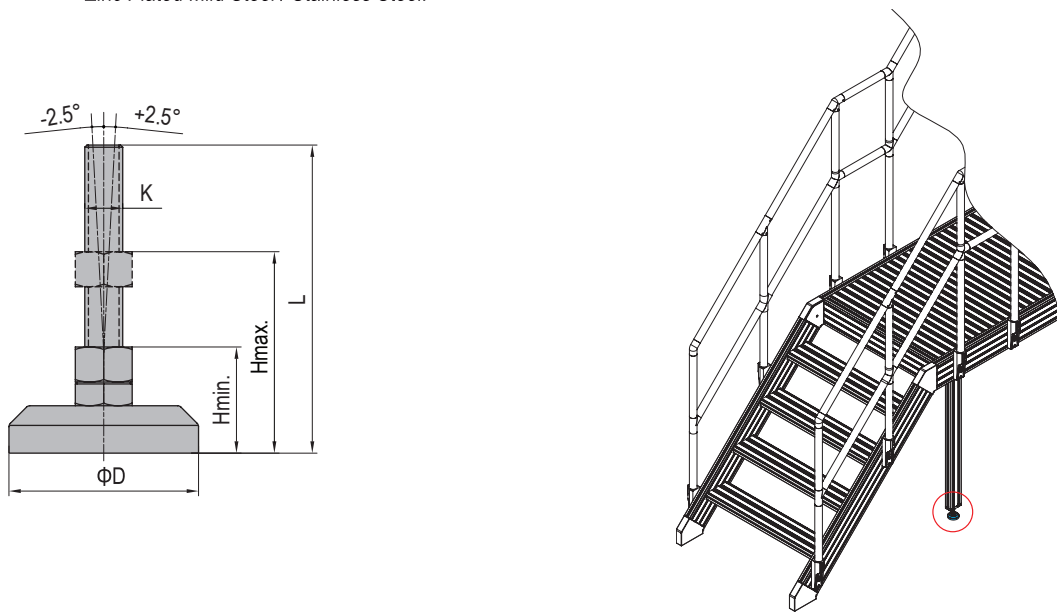
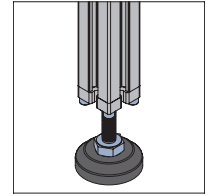

Descripción	D (mm)	KxL (mm)	H min. (mm)	H max. (mm)	Carga Estática Máx. (N)	Masa (g)	Part No.
Pivot Foot-Zinc Plate Steel	60	M16x158	45	120	30000	596	5.24.60.16.160
	60	M20x178	50	130	35000	796	5.24.60.20.180
	80	M16x158	45	120	30000	780	5.24.80.16.160
	80	M20x178	50	130	35000	945	5.24.80.20.180
Pivot Foot-Stainless Steel	60	M16x158	45	120	30000	600	5.24.60.16.160.SS
	60	M20x178	50	130	35000	803	5.24.60.20.180.SS
	80	M16x158	45	120	30000	785	5.24.80.16.160.SS
	80	M20x178	50	130	35000	950	5.24.80.20.180.SS

\* Otros diseños de patas de apoyo disponibles /Other pivot foot designs available

## Elementos de Apoyo

### Floor Elements

### Base de Refuerzo

#### Base Angle

La Base de Refuerzo permite mejorar la estabilidad de la estructura que apoya sobre patas de nivelación.  
 The Base Angle improves the stability of the structure when leveling feet are used.

Material: Acero al carbono con tratamiento superficial de electroforesis color negro.  
 Mild steel with powder coating black.

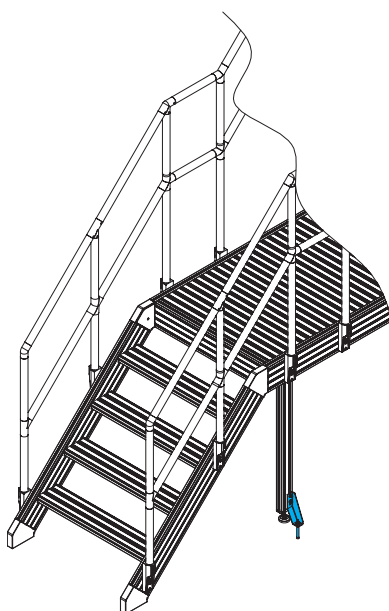
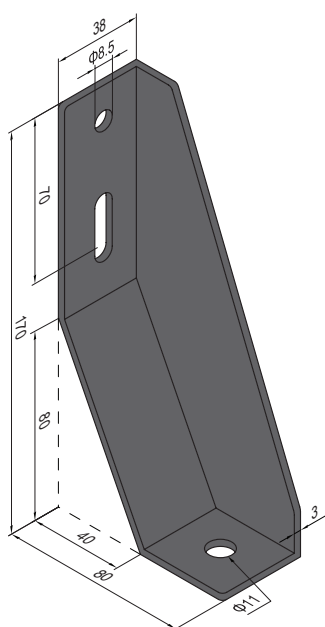
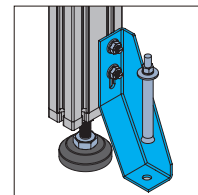

Descripción	Fastening Set	Masa (g)	Part No.
Base Angle-Left (pcs)		346	5.51.L
Base Angle-Left (set)	2xC+1xAA	443	5.51.L.ST
Base Angle-Right (pcs)		346	5.51.R
Base Angle-Right (set)	2xC+1xAA	443	5.51.R.ST
Base Angle-L+R (pair)		692	5.51.P
Base Angle-L+R (set)	4xC+2xAA	886	5.51.P.ST

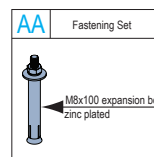
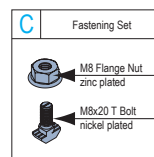



Sistema de Ensamble Modular  
*Modular Assembly System*

MAS

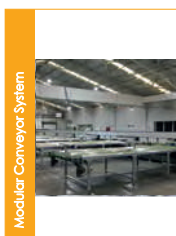

Sistema de Transportadores Modulares  
*Modular Conveyor System*

MCS



Sistema de Plataformas y Escaleras  
*Stair and Platform System*

SPS



Sistema de Cerramientos de Seguridad  
*Machine Guard System*

MGS

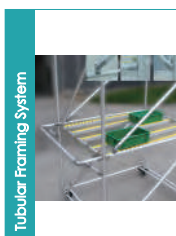

Sistema de Estructuras Tubulares  
*Tubular Framing System*

TFS



Alutipo SRL  
Web: [www.alutipo.com](http://www.alutipo.com)  
Email: [info@alutipo.com](mailto:info@alutipo.com)

# Stair and Platform System